

B

VANE PUMPS

Pump Type	Maximum Operating Pressure MPa (PSI)	Output Flow at 1200 r/min at No-Load		Catalogue No.
		L/min	U.S.GPM	
"PVL" Series Single Pumps	5 (730)	PVL1		Pub. EC-0116
Single Pumps	7 (1020)	50T 150T 250F 500F		Pub. EC-0117
Double Pumps	7 (1020)	Small Volume	(50) (150) (250)	
		Large Volume	(50) (150) (250)	
Combination Pumps	7 (1020)	Small Volume	(50)	
		Large Volume	(50) (150)	
"PV2R" Series Single Pumps	21 (3050)	PV2R1 PV2R2 PV2R3 PV2R4		Pub. EC-0118
"PV2R" Series Double Pumps	21 (3050)	Small Volume	(PV2R1) (PV2R2);(PV2R3)	
		Large Volume	(PV2R2) (PV2R3);(PV2R4)	
"PV11R" Series Single Pumps	40 (5800)	PV11R10 PV11R20		Pub. EC-0119



"PVL" SERIES

Fixed Displacement - Single

PVL1

VANE
PUMPS

Up to 5 MPa (730 PSI), 10.6 cm³/rev (.647 CU.IN./rev)

B

The PVL series single pumps are designed for use with small size machine tools requiring comparatively low pressure and small flow rates.

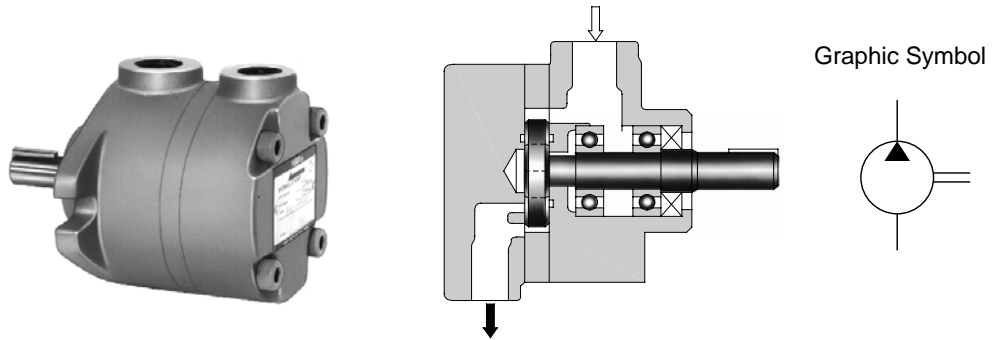

Specifications

Model Numbers	Geometric Displacement cm ³ /rev (cu.in./rev)	Max. Operating Pressure MPa (PSI)	Output Flow & Input Power	Shaft Speed Range r/min		Approx. Mass kg (lbs.)	
				Max.	Min.	Flange Mtg.	Foot Mtg.
PVL1- 2-*-RA-*-31/3180/3190	1.5 (.092)	5 (730)	Refer to Page 5	1800	950*	3.3 (7.3)	5.7 (12.6)
PVL1- 3-*-RA-*-31/3180/3190	2.7 (.165)						
PVL1- 4-*-RA-*-31/3180/3190	3.7 (.226)						
PVL1- 6-*-RA-*-31/3180/3190	5.7 (.348)						
PVL1- 8-*-RA-*-31/3180/3190	7.8 (.476)						
PVL1-11-*-RA-*-31/3180/3190	10.6 (.647)						

★ However, when starting the pump at low speed, maximum viscosity is restricted. Refer to Page 2, item "Hydraulic Fluids" for maximum viscosity.

Model Number Designation

PVL1	-4	-L	-R	A	-K	-31	*
Series Number	Nominal Displacement cm ³ /rev	Mounting	Direction of Rotation	Discharge Port Position	Shaft Extension	Design Number	Design Standard
PVL1 (Threaded Connections)	2 3 4 6 8 11	L: Foot Mtg. F: Flange Mtg.	(Viewed from Shaft End) R: Clockwise ★1 (Normal)	A: Upwards (Normal)	K: Keyed Shaft V: Tang Shaft	31	Refer to ★2

★ 1. Available to supply pump with anti-clockwise rotation. Consult Yuken for details.

★ 2. Design Standards: None Japanese Standard "JIS"
80 European Design Standard
90 N. American Design Standard

■ Hydraulic Fluids**1. Type of Hydraulic Fluids**

Petroleum Base Oils Use R&O (Rust and Oxidation inhibitor) type oils or anti-wear type oils.
(equivalent to ISO VG-32 or 46)

Note: Only Petroleum Base Oils can be used for hydraulic fluids.

2. Recommended Viscosity and Oil Temperature

Viscosity ranging between 20 - 400 mm²/s (100 - 1800 SSU).

Oil temperatures between 0/+70°C (32 - 158°F)

Use hydraulic fluids which satisfy the recommended viscosity and oil temperatures given above.

Note that if the PVL1 pump is started at a low speed of 950 r/min, the maximum fluid viscosity is limited to 200 mm²/s (910 SSU).

3. Control of Contamination

Contamination of hydraulic fluids results in pump failures and reduced pump lives. Carry out sufficient contamination control for hydraulic fluids and keep contamination level within NAS class 12.

Also, use a 100 μm (150-mesh) tank filter on the suction side and install it more than 50 mm (2 in.) away from the tank bottom.

■ Instructions**1. Alignment of Shaft**

Employ a flexible coupling whenever possible, and avoid any stress from bending or thrust.

Maximum permissible misalignment is less than 0.1 mm (.004 inches) TIR and maximum permissible misangular is less than 0.2°.

2. Suction Pressure

Set the suction pressure within -20 to +30 kPa (5.9 in. Hg vacuum to +4.3 PSIG) at the pump inlet.

In addition, use suction pipes having the sizes shown in the dimensional drawings. If the pump is installed above the tank level, set the suction port more than 1.0 m (3.3 ft.) below from the oil level.

3. Precautions at Starting

At an initial operation or at an operation after a long rest, the pump may have difficulty in sucking up the fluid. In such cases, an air bleed valve should be installed beforehand on the discharge side (model No. ST1004-*-10*, catalogue No. Pub. EC-3001.), or discharge air by slightly slackening the connection on the discharge side. At starting, operate the pump intermittently as far as possible with no load.

For fluid viscosity at starting, see the item "Hydraulic Fluids" above.

4. Other Precautions

If a PVL1 series single pump is used at speed below 1200 r/min, install the pump with the suction port upside so that the pump can suck up the fluid easily at starting.

Flange Mtg.

Keyed Shaft: PVL1-*F-RA-K-31/3180/3190

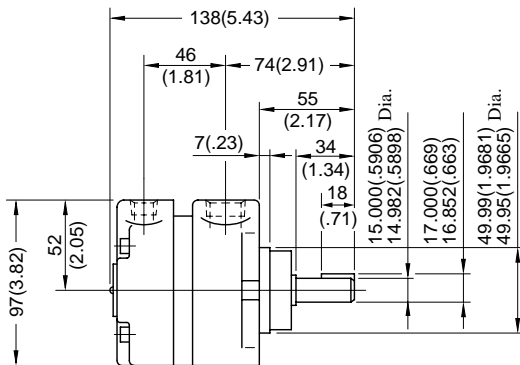
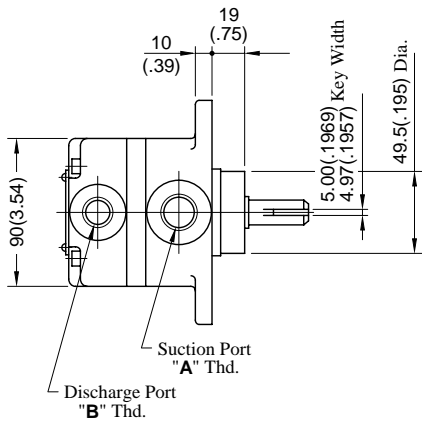

Model Numbers	"A" Thd.	"B" Thd.
PVL1-*F-RA-K-31	Rc 1/2	Rc 3/8
PVL1-*F-RA-K-3180	1/2 BSP.F	3/8 BSP.F
PVL1-*F-RA-K-3190	1/2 NPT	3/8 NPT

Tang Shaft.

PVL1-*F-RA-V-31/3180/3190

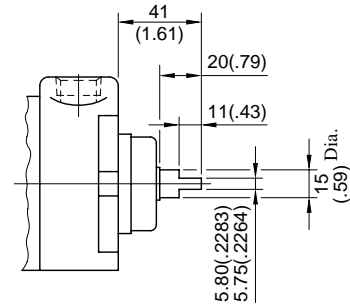

• For other dimensions, refer to "Keyed Shaft".

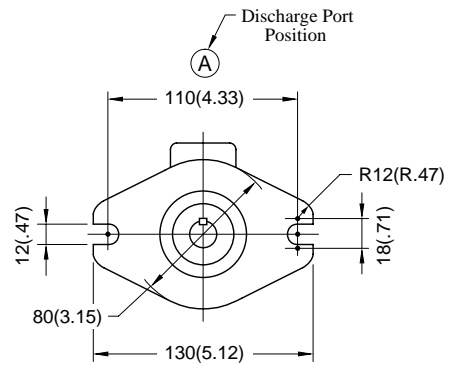

**DIMENSIONS IN
MILLIMETRES (INCHES)**

Foot Mtg., Keyed Shaft: PVL1-*L-RA-K-31/3180/3190

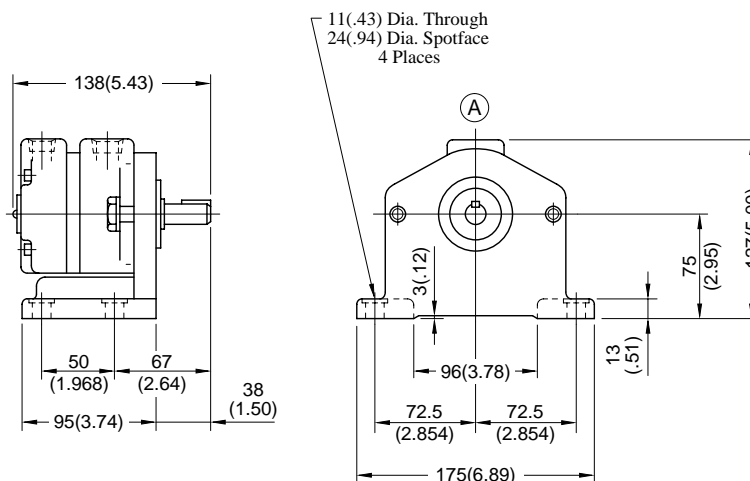

• For other dimensions, refer to "Flange Mtg.".

CAUTION

When making replacement of seals or bearing, please do it carefully after reading through the relevant instructions in the Operator's Manual.

PVL1-**-RA-*-31/3180/3190

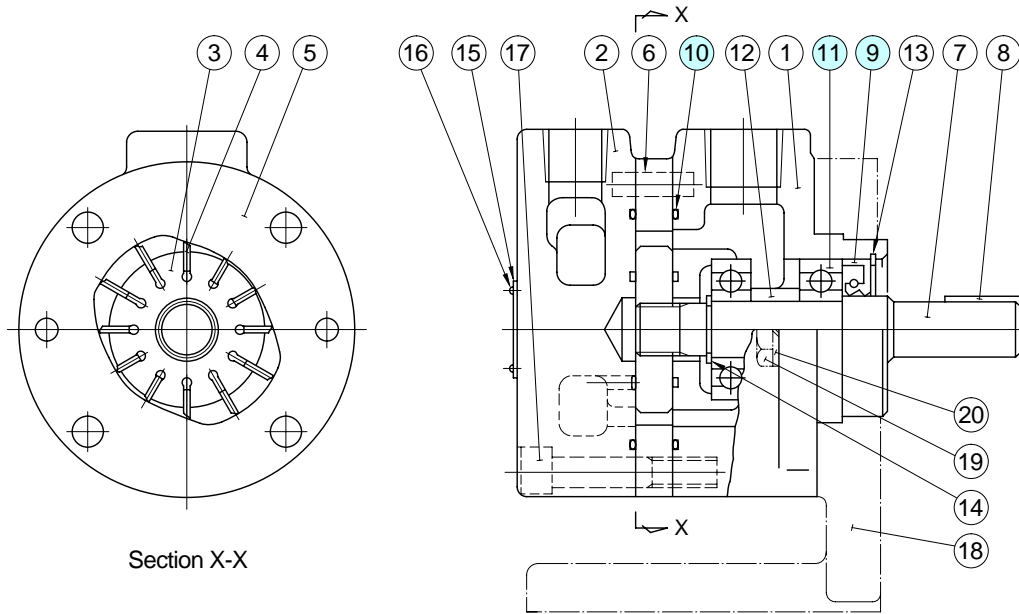

Item	Name of Parts	Part Numbers	Qty.	Remarks
9	Oil Seal	ISD 20 35 8	1	} Included in Seal Kit (Kit No. : KS-PVL1-31)
10	O-Ring	S 60	2	
11	Bearing	6003	2	

Typical Noise Level Characteristics

Measuring conditions

Oil viscosity 20 mm²/s (100 SSU)
 Point of measurement one metre (3.3 ft.) horizontally away from pump head cover
 Back ground noise level 40 dB (A)

PVL1-2

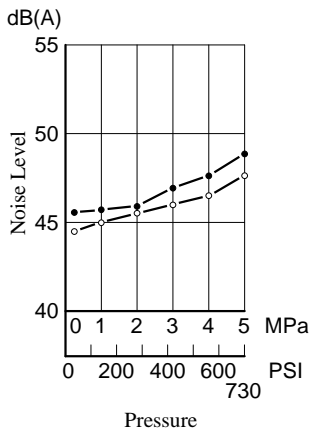

PVL1-3

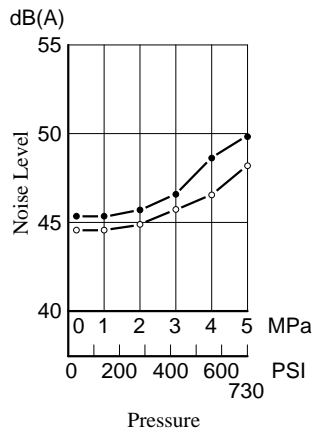

PVL1-4

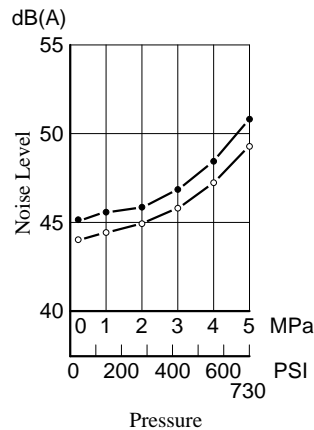

PVL1-6

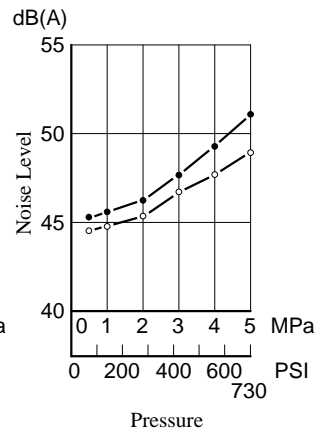

Viscosity 20 mm²/s (100 SSU) [ISO VG32 oils, 50°C (122°F)]

● PVL1-2

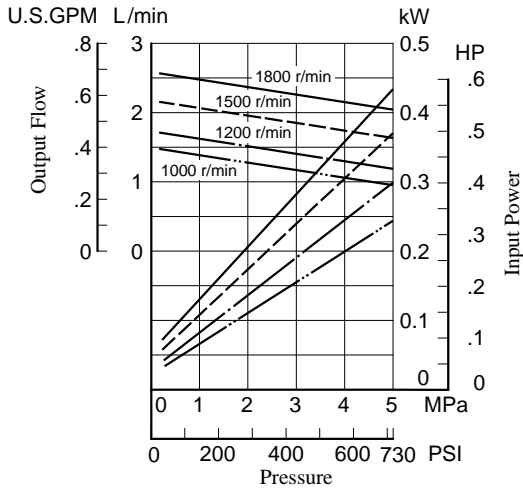

● PVL1-3

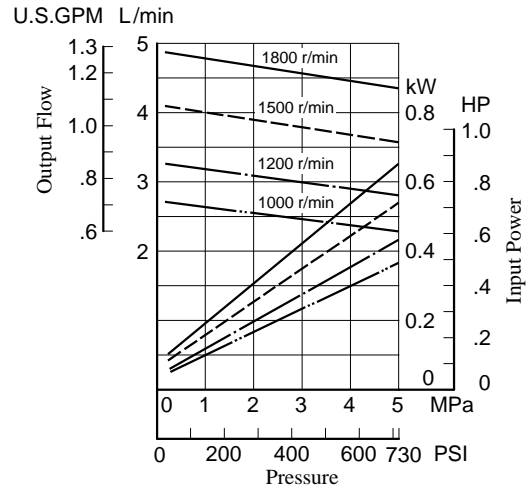

● PVL1-4

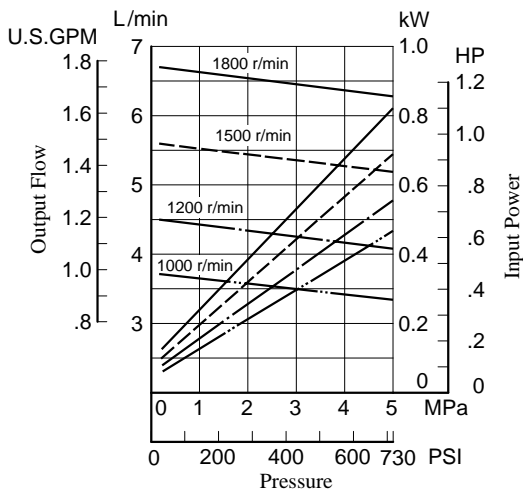

● PVL1-6

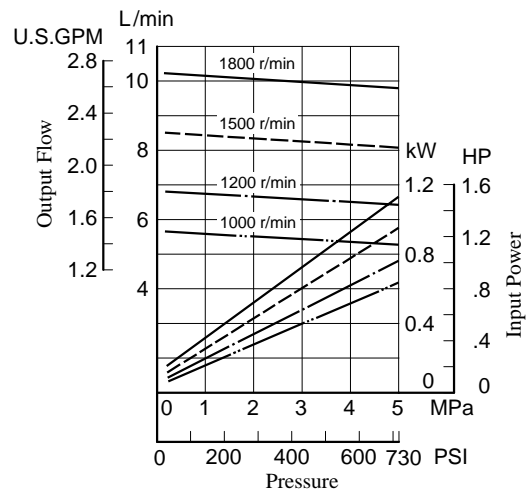

● PVL1-8

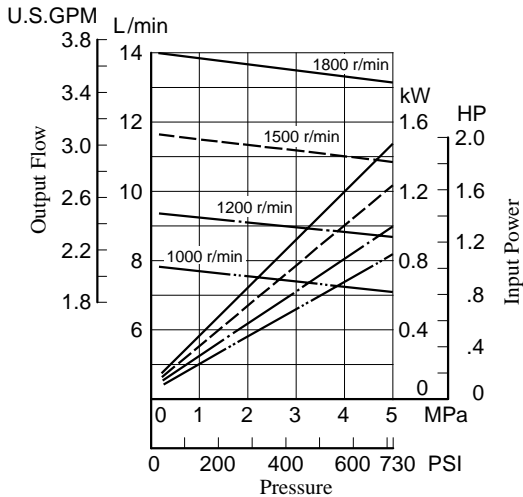

● PVL1-11

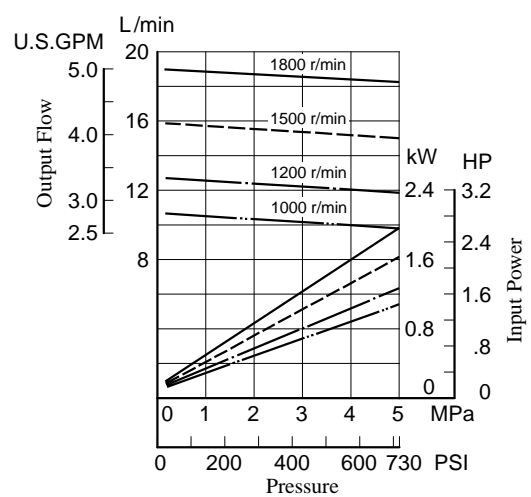

Up to 7 MPa (1020 PSI), 498 cm³/rev (30.34 CU.IN./rev)

Single Pumps

These pumps are widely used as a source of hydraulic power. They combine stable performance and robust construction with a wide range of delivery rates.

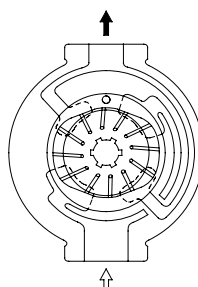
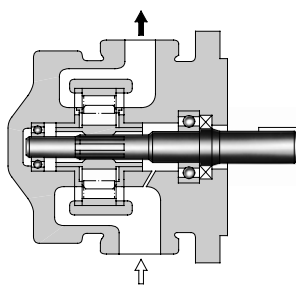

Graphic Symbol

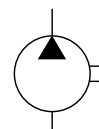

Double Pumps

Two single pumps, driven by a common shaft, have two discharge ports so that the output flow can be supplied to separate circuits.

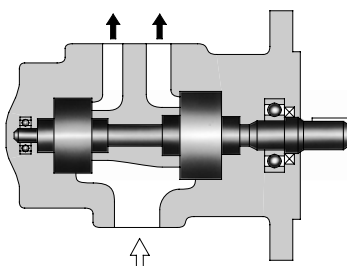
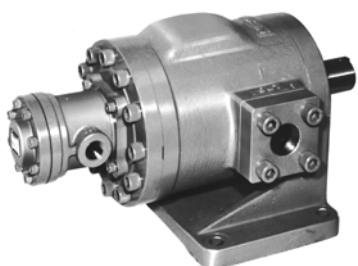

Graphic Symbols

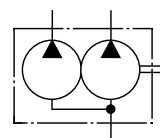

5050T
50150T

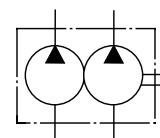

150150T
50250F
150250F

Combination Pumps

Consists of a double pump with either two relief valves, or one relief and one unloading and check valve incorporated within a common housing. The pressure of each pump can be independently adjusted. Remote control or high-low two-pressure control is possible.

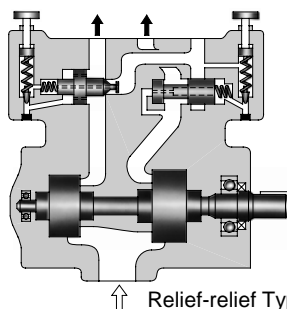
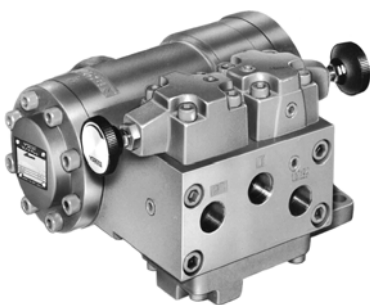

Relief-relief Type

Graphic Symbols

• Relief-relief Type

• Relief-unloading Type

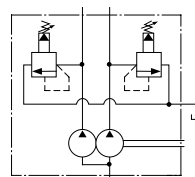

5050CT
50150CT

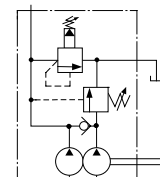

5050CT
50150CT

■ Hydraulic Fluids

1. Type of hydraulic fluids

Any hydraulic fluid listed in the table 1 below can be used. However, the specifications of the pumps such as maximum pump speed may be changed according to the type of hydraulic fluids to be used. For details, please refer to the specifications of the pump concerned.

● Hydraulic fluids

(Table 1)

Type of Fluids	Descriptions
Petroleum Base Oils	Use anti-wear type oils or R & O (Rust and Oxidation inhibitor) type oils (equivalent to ISO VG32 or 46).
Synthetic Fluids	Use phosphate ester type fluids. When phosphate ester type fluid is used, prefix "F-" to the model number because the special seals (fluororubber) are required to be used.
Water Containing Fluids	Consult your Yuken representative in advance.

2. Fluid viscosity and temperature

Use the hydraulic fluids which satisfy the recommended viscosity and oil temperature given in the Table 2 below. However, please note that if any of the pumps listed in the Table 3 is started at low speed, the maximum fluid viscosity is limited.

● Fluid viscosity and temperature

(Table 2)

Fluid	Temperature °C (°F)	Viscosity mm ² /s(SSU)
Petroleum Base Oils	0-70 (32-158)	20-400 (100-1800)
Phosphate Esters		

● Maximum viscosity for low start-up speed

(Table 3)

Pump Type	Start-up Speed r/min	Max. Viscosity mm ² /s (SSU)
50T, 5050T, 50150T 50250F, 5050ST 5050CT, 50150ST 50150CT	600	100 (455)
	950	200 (910)

3. Control of contamination

Contamination of hydraulic fluids results in pump failures and reduced pump lives. Carry out sufficient contamination control for hydraulic fluids and keep contamination level within NAS class 12.

Also, use a 100 μm (150-mesh) tank filter on the suction side and install it more than 50 mm (2 in.) away from the tank bottom.

■ Instructions

1. Alignment of shaft

Employ a flexible coupling whenever possible, and avoid any stress from bending or thrust.

Maximum permissible misalignment is less than 0.1 mm (.004 inches) TIR and maximum permissible misangular is less than 0.2°.

2. Suction pressure

Set suction pressures, at the pump inlet, at the values shown in the table below.

In addition, use suction pipes having the sizes shown in the dimensional drawings. If the pump is installed above the tank level, set the suction port more than 1.0 m (3.3 ft.) below from the oil level {or 0.8 m (2.6 ft.) if a phosphate ester fluid is used}.

Model Numbers		Suction Pressure		
		Minimum		Maximum
		Petroleum base oil	Phosphate ester type fluid Water containing fluid	
Single Pumps	50T, 150T, 250F	-20 kPa (5.9 in. Hg Vacuum)	-16 kPa (4.7 in. Hg Vacuum)	+140 kPa (+20 PSIG)
Double Pumps	5050T, 50150T	-20 kPa* (5.9 in. Hg Vacuum)		
	150150T, 50250F 150250F	-20 kPa (5.9 in. Hg Vacuum)		
Combination Pumps	5050ST, 50150ST 5050CT, 50150CT	-20 kPa* (5.9 in. Hg Vacuum)		

★ With some nominal displacement, minimum suction pressures are limited because of pump speeds. For details, see the pump specifications.

3. Precautions at starting

At an initial operation or at an operation after a long rest, the pump may have difficulty in sucking up the fluid. In such cases, an air bleed valve should be installed beforehand on the discharge side (model No. ST1004-* -10*, catalogue No. Pub. EC-3001.), or discharge air by slightly slackening the connection on the discharge side. At starting, operate the pump intermittently as far as possible with no load.

For fluid viscosity at starting, see the item of "Hydraulic Fluids".



Yuken can offer a large volume pump described below.
Consult Yuken for the details.

Model Numbers	500F-*-*-RL-20/2080/2090
Max Operating Pressure MPa (PSI)	7 (1020)
Output flow at 7 MPa (1020 PSI) and 1200 r/min with 20 mm ² /s (100SSU) fluid L/min (U.S.GPM)	324-530 (85.6-140.0)
Shaft Speed Range r/min	600-1200

■ Specifications

Model Numbers	Geometric Displacement cm ³ /rev (cu.in/rev)	Maximum Operating Pressure MPa (PSI)	Output Flow & Input Power	Shaft Speed Range r/min		Approx. Mass kg (lbs.)	
				Max.	Min.	Foot Mtg.	Flange Mtg.
50T-7	6.8 (.415)	7 (1020)	Refer to Pages 7 & 8.	2000 ^{★2}	800	10.5 (23.2)	9.0 (19.8)
50T-12	11.6 (.708)			1800 ^{★2}	600		
50T-17	16.5 (1.007)						
50T-23	22.9 (1.397)						
50T-26	25.9 (1.580)						
50T-36	36.0 (2.20)						
150T-48	47.7 (2.91)	7 (1020)	Refer to Pages 8 & 9.	1500 ^{★2}	600	26 (57.3)	25 (55.1)
150T-61	61.1 (3.73)			1200			
150T-75	74.9 (4.57)						
150T-94	93.6 (5.71)						
150T-116	115.6 (7.05)						
250F-134	133.9 (8.17)	7 (1020)	Refer to Page 10.	1200	600	120 (265)	113 (249)
250F-153	153.1 (9.34)						
250F-176	175.8 (10.73)						
250F-200	201.0 (12.27)						

★1. The maximum operating pressure is constant irrespective of fluid types.

★2. If phosphate ester type fluids are used, the maximum speed is restricted to 1200 r/min.

■ Model Number Designation

F-	50T	-7	-L	-R	L	-30	*
Special Seals	Series Number	Nominal Displacement cm ³ /rev	Mounting	Direction of Rotation	Discharge Port Position	Design Number	Design Standard
F: For phosphate ester type fluids (Omit if not required)	50T (Threaded Connections)	7, 12, 17, 23, 26, 36	L: Foot Mtg.	(Viewed from Shaft End)		30	Refer to ★2
	150T (Threaded Connections)	48, 61, 75, 94, 116	F: Flange Mtg.	R: Clockwise ★1 (Normal)	L: On Left Hand (Normal)	40	
	250F (Flanged Connections)	134, 153, 176, 200		40			

★1. Available to supply pump with anti-clockwise rotation. Consult Yuken for details.

★2. Design Standards: None Japanese Standard "JIS"
80 European Design Standard
90 N. American Design Standard

Foot Mtg.:50T-*-L-RL-30/3080/3090

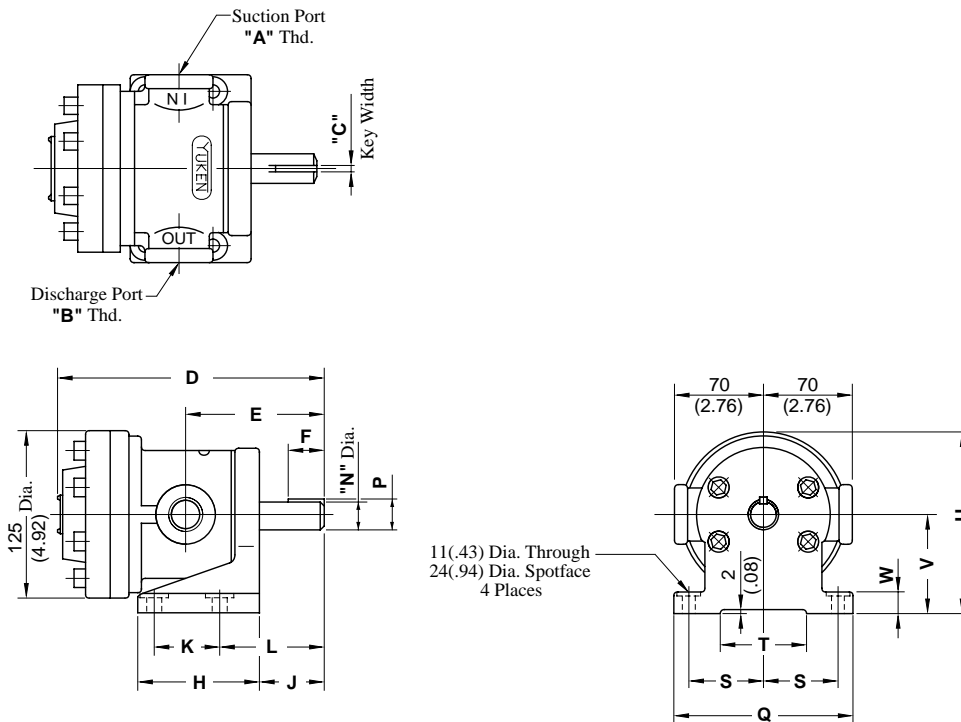

Model Numbers	"A" Thd.	"B" Thd.	Dimensions mm (Inches)									
			C	D	E	F	H	J	K	L	N	P
50T-*-L-RL-30	Rc 1	Rc 3/4	5.000(.1969) 4.970(.1957)	201 (7.91)	104 (4.09)	28 (1.10)	90 (3.54)	50 (1.969)	50 (1.969)	78 (3.07)	22.000(.8661) 21.979(.8653)	24.000(.945) 23.849(.939)
50T-*-L-RL-3080	1 BSP.F	3/4 BSP.F	4.760(.1874)	202 (7.95)	104.8 (4.13)	29 (1.14)	97 (3.82)	50.8 (2.000)	50.8 (2.000)	82.5 (3.25)	19.050(.7500)	21.570(.849)
50T-*-L-RL-3090	1 NPT	3/4 NPT	4.742(.1867)	202 (7.95)	104.8 (4.13)	29 (1.14)	97 (3.82)	50.8 (2.000)	50.8 (2.000)	82.5 (3.25)	19.029(.7429)	21.431(.844)

Model Numbers	Dimensions mm (Inches)					
	Q	S	T	U	V	W
50T-*-L-RL-30	140 (5.51)	58 (2.283)	65 (2.56)	137.5 (5.41)	75 (2.95)	15 (.59)
50T-*-L-RL-3080	130 (5.12)	50.8 (2.000)	50 (1.97)	132.3 (5.21)	69.8 (2.75)	12.7 (.50)
50T-*-L-RL-3090	130 (5.12)	50.8 (2.000)	50 (1.97)	132.3 (5.21)	69.8 (2.75)	12.7 (.50)

**DIMENSIONS IN
MILLIMETRES (INCHES)**

Flange Mtg.:50T-*-F-RL-30/3080/3090

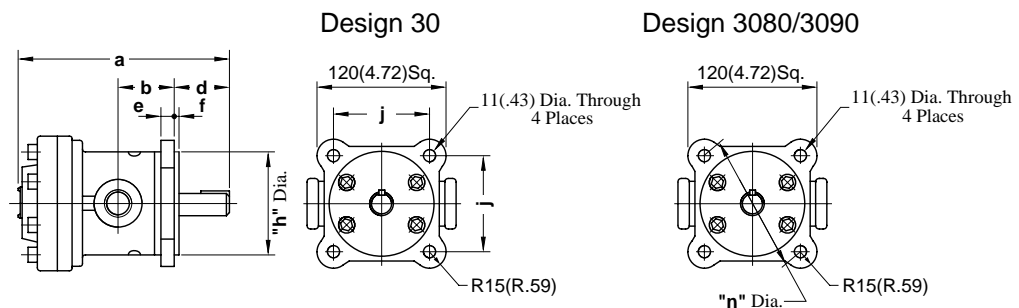

Model Numbers	Dimensions mm (Inchs)							
	a	b	d	e	f	h	j	n
50T-*-F-RL-30	201 (7.91)	54 (2.13)	50 (1.97)	15 (.59)	5 (.20)	96.000(3.780) 95.565(3.778)	90 (3.543)	—
50T-*-F-RL-3080	202 (7.95)	49.3 (1.94)	55.6 (2.19)	12.7 (.50)	4.7 (.19)	95.200(3.748)	—	127 (5.000)
50T-*-F-RL-3090	202 (7.95)	49.3 (1.94)	55.6 (2.19)	12.7 (.50)	4.7 (.19)	95.165(3.746)	—	127 (5.000)

• For other dimensions, refer to "Foot Mtg.".

Foot Mtg.:150T-*-L-RL-40/4080/4090

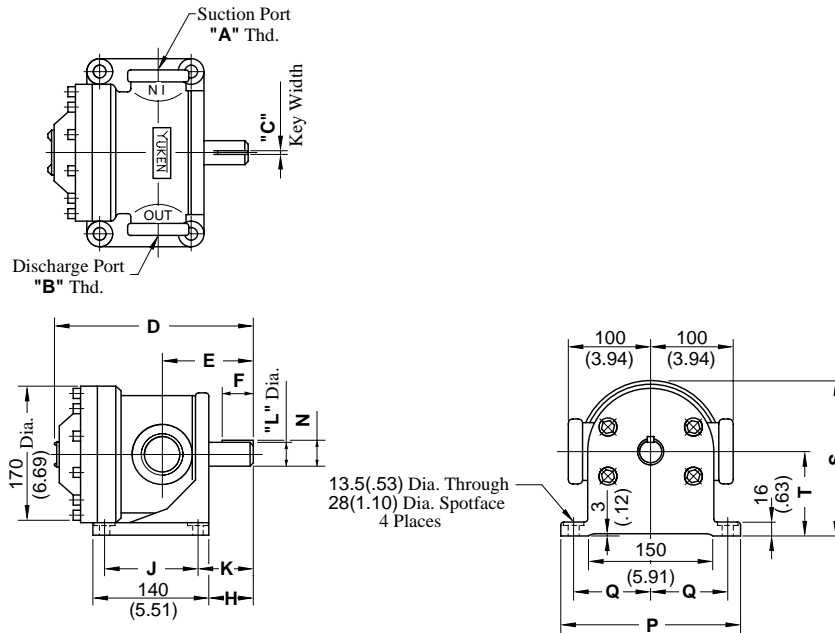

Model Numbers	"A" Thd.	"B" Thd.	Dimensions mm (Inches)					
			C	D	E	F	H	J
150T-*-L-RL-40	Rc 1-1/2	Rc 1-3/4	7.000(.2756) 6.964(.2742)	237 (9.33)	108.5 (4.27)	32 (1.26)	53 (2.09)	114 (4.488)
150T-*-L-RL-4080	1-1/2 BSP.F	1-1/4 BSP.F	4.760(.1874)	237.5 (9.35)	109 (4.29)	38 (1.50)	54 (2.18)	114.3 (4.500)
150T-*-L-RL-4090	1-1/2 NPT	1-1/4 NPT	4.742(.1867)					

Model Numbers	Dimensions mm (Inches)						
	K	L	N	P	Q	S	T
150T-*-L-RL-40	66 (2.60)	30.000 (1.1811) 29.979 (1.1803)	33.000 (1.299) 32.843 (1.293)	226 (8.86)	98.5 (3.878)	186.5 (7.34)	101.5 (3.996)
150T-*-L-RL-4080	66.7 (2.63)	25.400 (1.0000)	27.400 (1.079)	222 (8.74)	98.4 (3.874)	186.6 (7.35)	101.6 (4.000)
150T-*-L-RL-4090		25.379 (.9992)	27.221 (1.072)				

DIMENSIONS IN
MILLIMETRES (INCHES)

Flange Mtg.:150T-*-F-RL-40/4080/4090

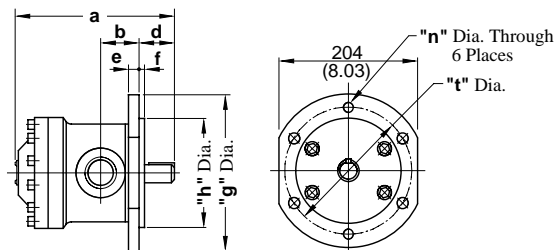

Model Numbers	Dimensions mm (Inches)								
	a	b	d	e	f	g	h	n	t
150T-*-F-RL-40	237 (9.33)	58 (2.28)	50.5 (1.99)	17.5 (.69)	5 (.20)	230 (9.06)	160.000 (6.299) 159.960 (6.297)	13.5 (.53)	187 (7.36)
150T-*-F-RL-4080	237.5 (9.35)	58.2 (2.29)	50.8 (2.00)	16 (.63)	6.4 (.25)	228 (8.98)	158.750 (6.250) 158.674 (6.247)	17.5 (.69)	187.3 (7.37)
150T-*-F-RL-4090									

• For other dimensions, refer to "Foot Mtg.".

Foot Mtg.:250F-*-L-RL-40/4080/4090

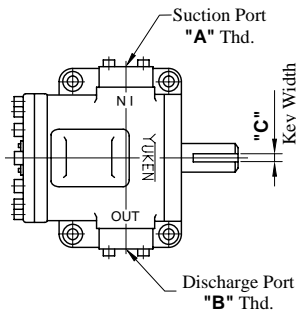

For Reference: Dimensions of Pipe Flange Mounting Surface

Suction Port Discharge Port

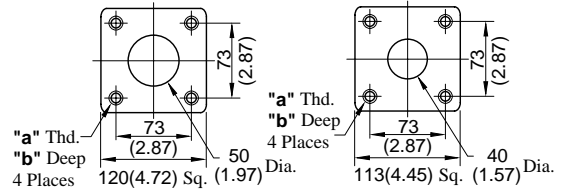

Model Numbers	"a" Thd.	b mm (IN.)
250F-*-L-RL-40	M 16	29 (1.14)
250F-*-L-RL-4080	M 16	29 (1.14)
250F-*-L-RL-4090	5/8-11 UNC	25 (.98)

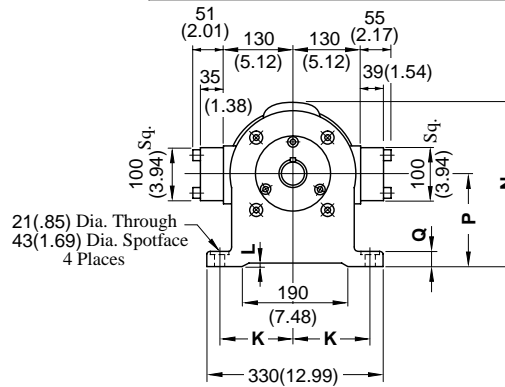
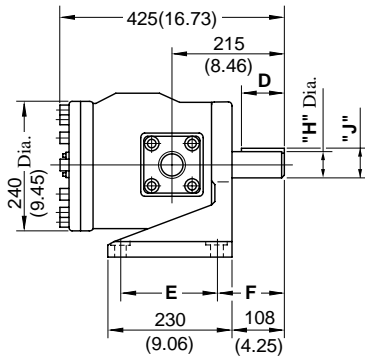

Model Numbers	"A" Thd.	"B" Thd.	Dimensions mm (Inches)				
			C	D	E	F	H
250F-*-L-RL-40	Rc 2	Rc 1-1/2	12.000 (.4724) 11.957 (.4707)	85 (3.35)	180 (7.087)	133 (5.24)	50.000 (1.9685) 49.975 (1.9675)
250F-*-L-RL-4080	2 BSP.F	1-1/2 BSP.F	12.700 (.5000)	87.3 (3.44)	177.8 (7.000)	133.4 (5.25)	50.800 (2.0000)
250F-*-L-RL-4090	2 NPT	1-1/2 NPT	12.673 (.4989)				50.770 (1.9988)

Model Numbers	Dimensions mm (Inches)					
	J	K	L	N	P	Q
250F-*-L-RL-40	53.000 (2.087) 52.785 (2.078)	140 (5.512)	5 (.20)	305 (12.01)	170 (6.69)	28 (1.10)
250F-*-L-RL-4080	54.900 (2.161)	139.7 (5.500)	6.5 (.26)	306.5 (12.07)	171.5 (6.75)	29.5 (1.16)
250F-*-L-RL-4090	54.640 (2.151)					

DIMENSIONS IN MILLIMETRES (INCHES)

Flange Mtg.:250F-*-F-RL-40/4080/4090

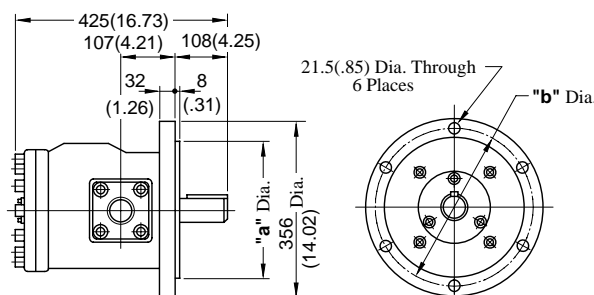

Model Numbers	Dimensions mm (Inches)	
	a	b
250F-*-F-RL-40	280.000 (11.024) 279.948 (11.022)	318 (12.52)
250F-*-F-RL-4080	279.370 (10.999)	317.5 (12.50)
250F-*-F-RL-4090	279.290 (10.996)	

• For other dimensions, refer to "Foot Mtg.".

Viscosity 20 mm²/s (100 SSU) [ISO VG32 Oils, 50°C (122°F)]

● 50T-7

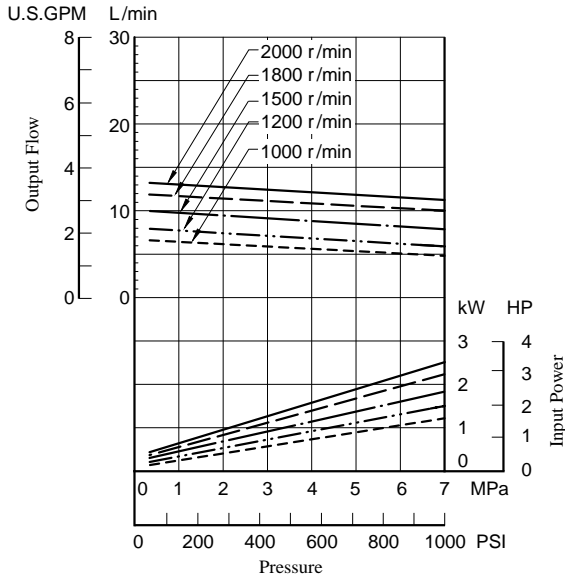

● 50T-12

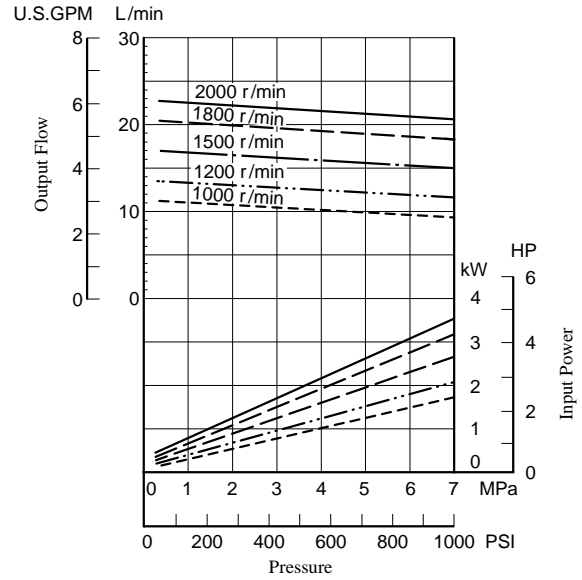

● 50T-17

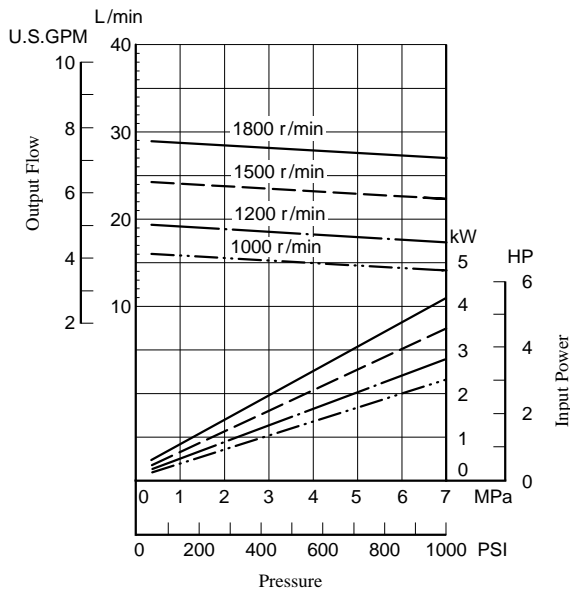

● 50T-23

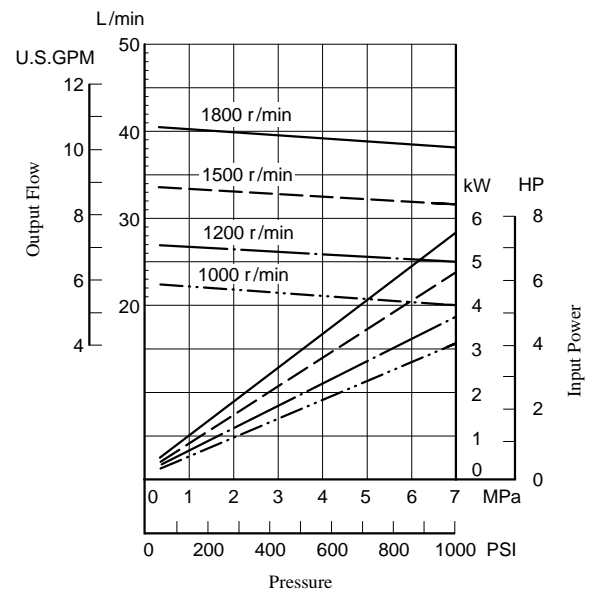

Viscosity 20 mm²/s (100 SSU) [ISO VG32 Oils, 50°C (122°F)]

● 50T-26

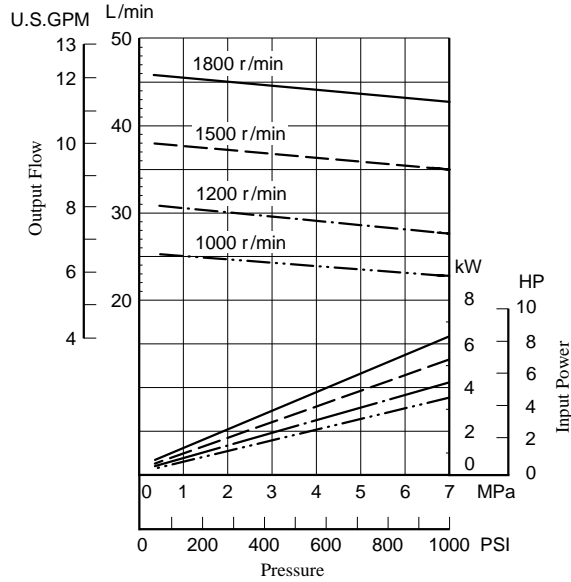

● 50T-36

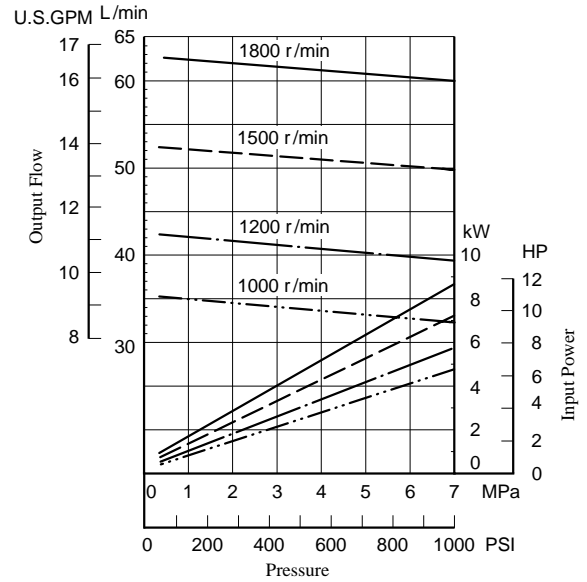

● 150T-48

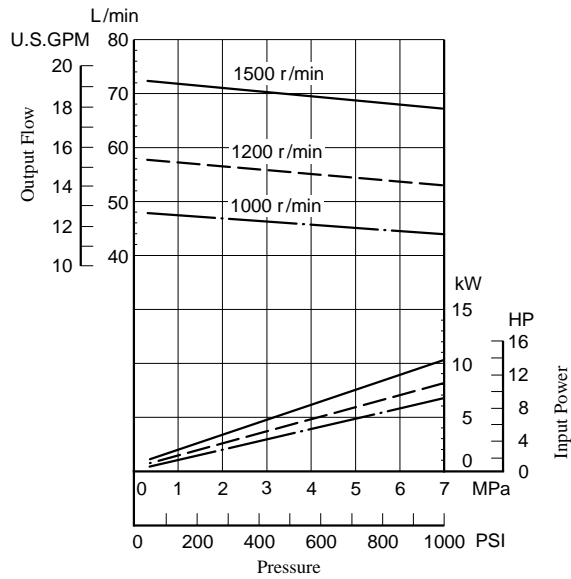

● 150T-61

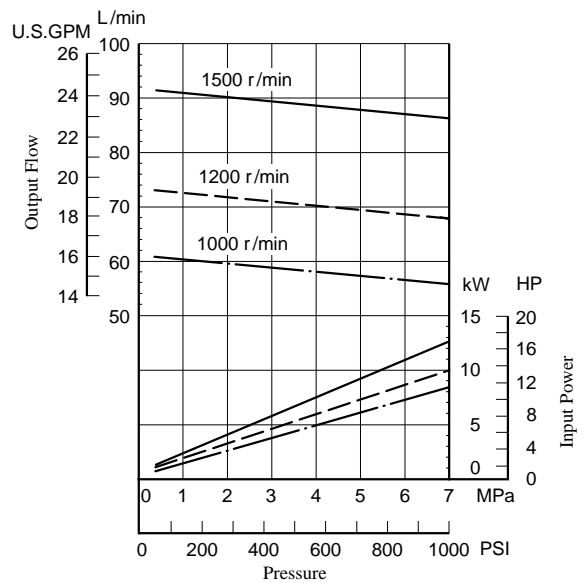

Viscosity 20 mm²/s (100 SSU) [ISO VG32 Oils, 50°C (122°F)]

● 150T-75

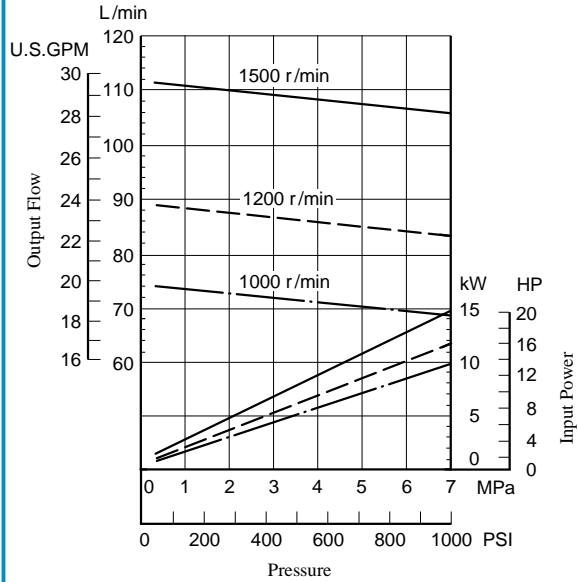

● 150T-94

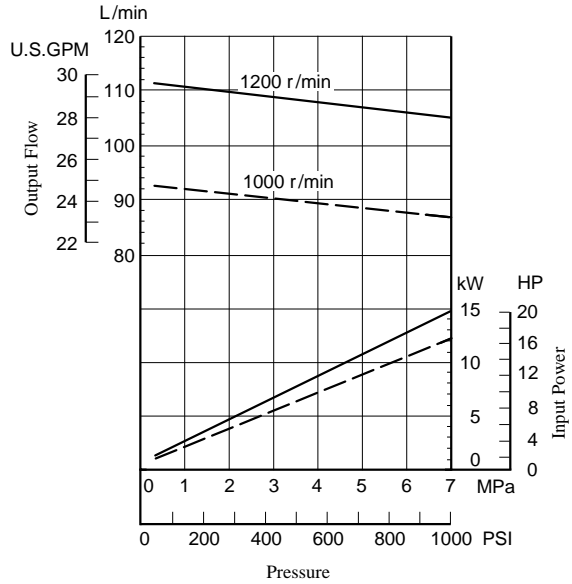

● 150T-116

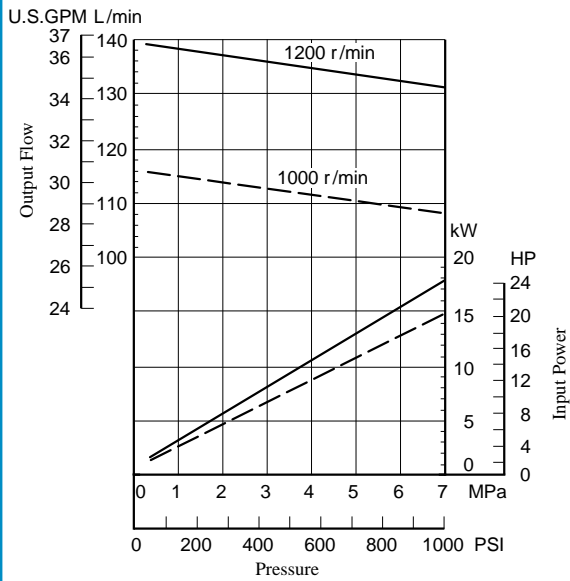

Viscosity 20 mm²/s (100 SSU) [ISO VG32 Oils, 50°C (122°F)]

● 250F-134

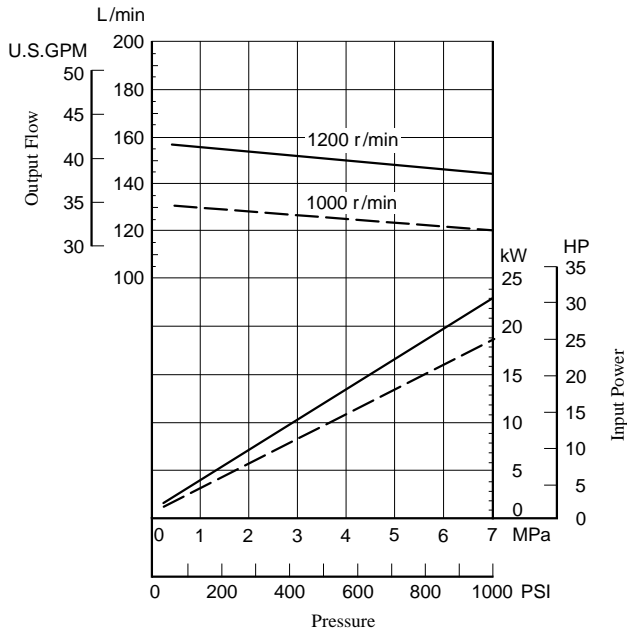

● 250F-153

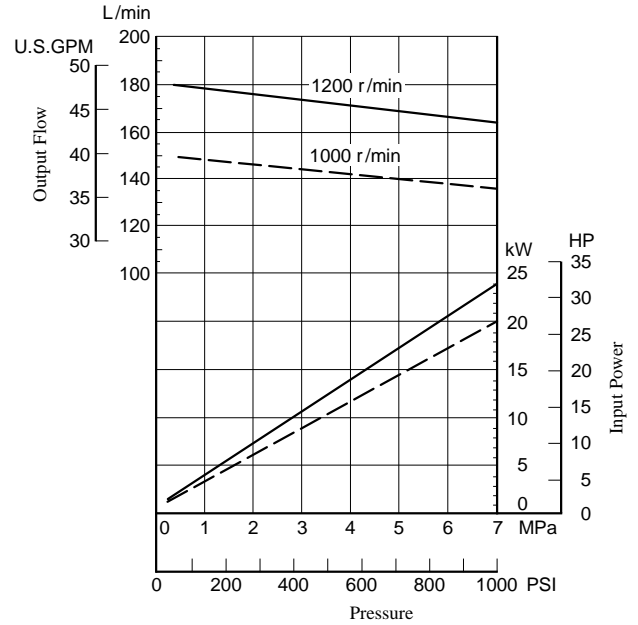

● 250F-176

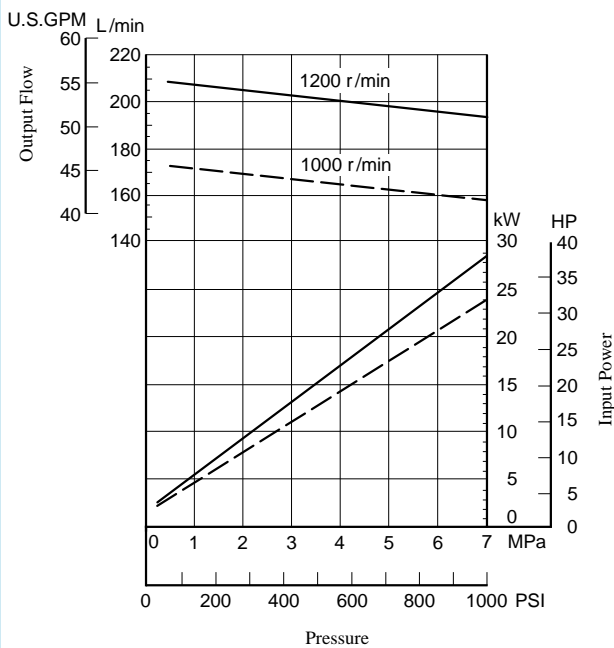

● 250F-200

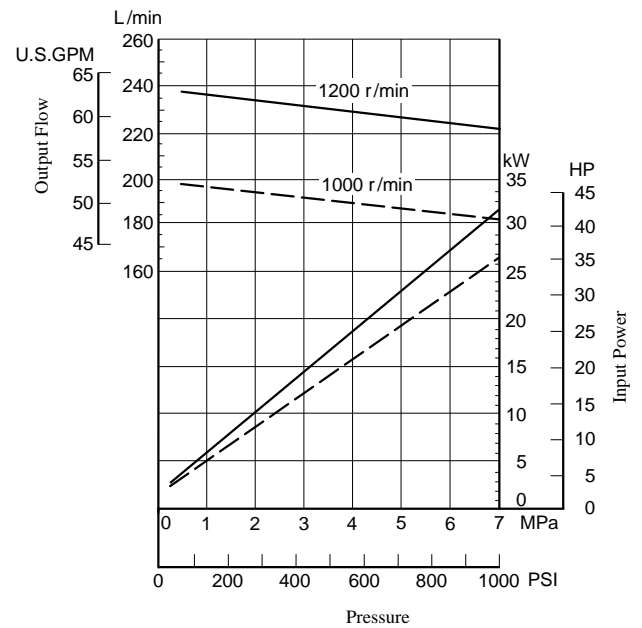

50T-*-*-RL-30/3080/3090
150T-*-*-RL-40/4080/4090

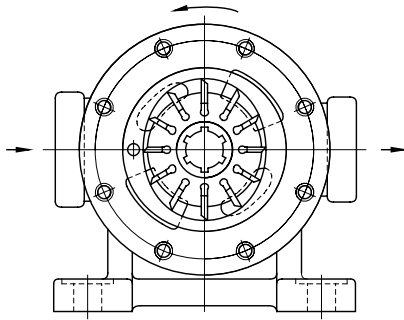

Section A-A

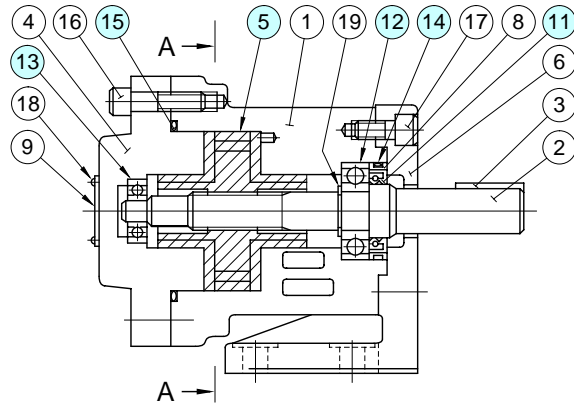

Item & Name Model Numbers	⑤ Cartridge Kit	⑪ Oil Seal	⑭ O-Ring	⑮ O-Ring	⑫ Bearing	⑬ Bearing	Seal Kit ² Numbers
50T-7-*-RL-30*	C50-7-30	ISPD25388	SO-NA-P41	SO-NA-A234	6204	6200	KS-50T-30
50T-12-*-RL-30*	C50-12-30						
50T-17-*-RL-30*	C50-17-30						
50T-23-*-RL-30*	C50-23-30						
50T-26-*-RL-30*	C50-26-30						
50T-36-*-RL-30*	C50-36-30						
150T-48-*-RL-40*	C150-48-40	ISPD32427	SO-NA-P46	SO-NA-A248	6205	6203	KS-150T-40
150T-61-*-RL-40*	C150-61-40						
150T-75-*-RL-40*	C150-75-40						
150T-94-*-RL-40*	C150-94-40						
150T-116-*-RL40*	C150-116-40						

★1. For pumps for phosphate ester type hydraulic fluids, seals are different from the above. Please contact us. ★2. Seal kits consist of ⑪ (oil seal) and ⑭ and ⑮ (o-rings).

⚠ CAUTION

When making replacement of seals, bearings or cartridge kits, please do it carefully after reading through the relevant instructions in the Operator's Manual.

250F-*-*-RL-40/4080/4090

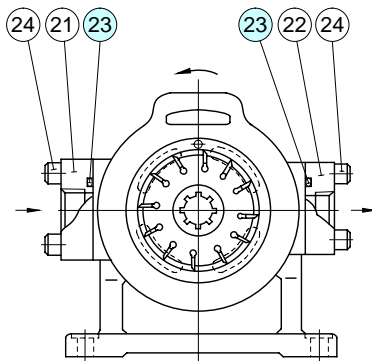

Section A-A

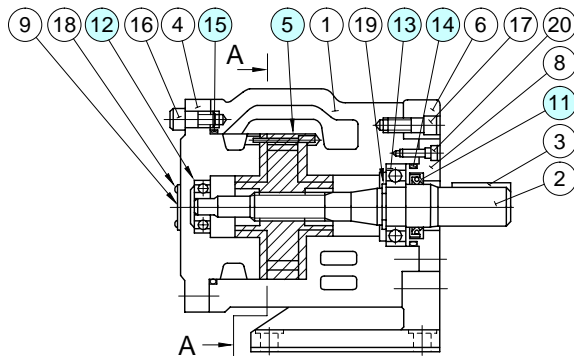

Item & Name Model Numbers	⑤ Cartridge Kit	⑪ Oil Seal	⑭ O-Ring	⑮ O-Ring	⑲ O-Ring	⑬ Bearing	⑫ Bearing	Seal Kit ² Numbers
250F-134-*-RL-40*	C250-134-40	ISPD527512	SO-NA-G95	SO-NB-G165	SO-NB-G60	6309	6305	KS-250F-40
250F-153-*-RL-40*	C250-153-40							
250F-176-*-RL-40*	C250-176-40							
250F-200-*-RL-40*	C250-200-40							

★1. For pumps for phosphate ester type hydraulic fluids, seals are different from the above. Please contact us. ★2. Seal kits consist of ⑪ (oil seal) and ⑭ and ⑮ and ⑲ (o-rings).

Specifications / Model Number Designation

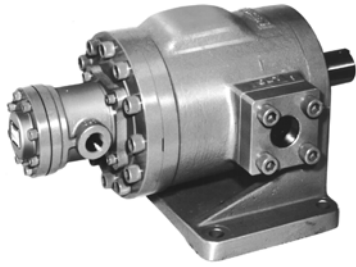

Yuken can offer a large volume double pump described below. Consult Yuken for the details.

Model Numbers	250250F-*-*-*-RL-20/2080/2090	
Max Operating Pres.	MPa (PSI)	7 (1020)
Output flow at 7 MPa (1020 PSI) and 1200 r/min with 20 mm ² /s (100 SSU)fluid	L/min (U.S.GPM)	(Each Pump) 162-265 (42.8-70)
Shaft Speed Range	r/min	600-1200

Specifications

Model Numbers	Max. Operating Pressure MPa (PSI)	Output Flow & Input Power		Shaft Speed Range r/min		Approx. Mass kg (lbs.)	
		Small Volume Pump	Large Volume Pump	Max.	Min.	Foot Mtg.	Flange Mtg.
5050T	7 ^{*1} (1020)	Same as Single Pump "50T" (Refer to pages 7 & 8)	Same as Single Pump "50T" (Refer to pages 7 & 8)	2000 ^{*2} ^{*6}	600 ^{*4}	31 (68.4)	29 (63.9)
50150T	7 ^{*1} (1020)	Same as Single Pump "50T" (Refer to pages 7 & 8)	Same as Single Pump "150T" (Refer to pages 8 & 9)	1200 ^{*3}	600 ^{*4}	60 (132)	55 (121)
150150T	7 ^{*1} (1020)	Same as Single Pump "150T" (Refer to pages 8 & 9)	Same as Single Pump "150T" (Refer to pages 8 & 9)	1500 ^{*5} ^{*6}	600	67 (148)	62 (137)
50250F	7 ^{*1} (1020)	Same as Single Pump "50T" (Refer to pages 7 & 8)	Same as Single Pump "250F" (Refer to page 10)	1200	600. ^{*4}	131 (289)	125 (276)
150250F	7 ^{*1} (1020)	Same as Single Pump "150T" (Refer to pages 8 & 9)	Same as Single Pump "250F" (Refer to page 10)	1200	600	146 (322)	140 (309)

- ★1. The maximum operating pressure is constant irrespective of fluid types.
- ★2. If nominal displacement 17, 23, 26 or 36 is used, the maximum pump speed is restricted as follows:
 ND. 17,23 1800 r/min
 26 1500 r/min
 36 1200 r/min
- ★3. If large-volume side nominal displacement 94 or 116 is used at a speed above 1000 r/min, restrict the suction pressure to -7 kPa (1.97 in. Hg. Vacuum). (For other models, restrict it to -20 kPa (5.9 in. Hg. Vacuum).)

- ★4. If nominal displacement 7 is used on the pump on small-volume side, the minimum speed is restricted to 800 r/min.
- ★5. If nominal displacement 94 or 116 is used, the maximum speed is restricted to 1200 r/min.
- ★6. If phosphate ester type fluids are used, the maximum speed is restricted to 1200 r/min.

Model Number Designation

F-	5050T	-7	-12	-L	-R	L	-40	*
Special Seals	Series Number	Small Volume Pump Nominal Displacement cm ³ /rev	Large Volume Pump Nominal Displacement cm ³ /rev	Mounting	Direction of Rotation	Discharge Port Position	Design Number	Design Std.
F: For phosphate ester type fluids (Omit if not required)	5050T (Threaded Connections)	7, 12, 17, 23, 26, 36	7, 12, 17, 23, 26, 36	L: Foot Mtg. F: Flange Mtg.	(Viewed from Shaft End) R: Clockwise ★1 (Normal)	L: On Left Hand (Normal)	40	Refer to ★2
	50150T (Threaded Connections)	7, 12, 17, 23, 26, 36	48, 61, 75, 94, 116				40	
	150150T (Threaded Connections)	48, 61, 75, 94, 116	48, 61, 75, 94, 116				20	
	50250F (Flange Connections)	7, 12, 17, 23, 26, 36	134, 153, 176, 200				40	
	150250F (Flange Connections)	48, 61, 75, 94, 116	134, 153, 176, 200				40	

- ★1. Available to supply pump with anti-clockwise rotation. Consult Yuken for details.
- ★2. Design Standards: None.....Japanese Standard "JIS"
 80.....European Design Standard
 90.....N. American Design Standard

Foot Mtg.:5050T-**-L-RL-40/4080/4090

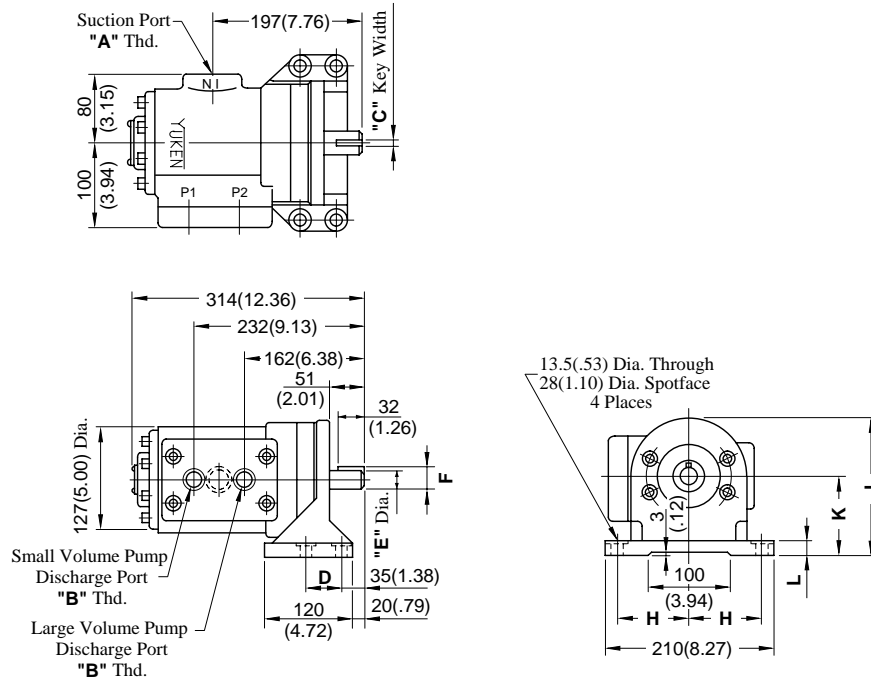

Model Numbers	"A" Thd.	"B" Thd.	Dimensions mm (Inches)							
			C	D	E	F	H	J	K	L
5050T-**-L-RL-40	Rc 1-1/2	Rc 3/4	7.000 (.2756) 6.964 (.2742)	50 (2.008)	25.000 (.9843) 24.979 (.9834)	28.000 (1.102) 24.743 (1.092)	90 (3.543)	167 (6.57)	95 (3.74)	20 (.79)
5050T-**-L-RL-4080	1-1/2 BSP.F	3/4 BSP.F	4.760 (.1874) 4.730 (.1862)	50.8 (2.000)	25.370 (.9988) 25.349 (.9980)	27.370 (1.078) 27.191 (1.071)	88.9 (3.500)	167.3 (6.59)	95.25 (3.75)	20.3 (.80)

DIMENSIONS IN
MILLIMETRES (INCHES)

Flange Mtg.:5050T-**-F-RL-40/4080/4090

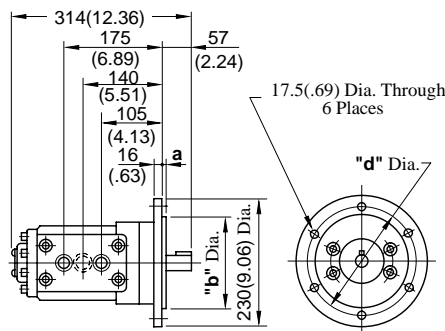

Model Numbers	Dimensions mm (Inches)		
	a	b	d
5050T-**-F-RL-40	6 (.24)	160.000 (6.299) 159.960 (6.298)	190 (7.48)
5050T-**-F-RL-4080	6.5 (.26)	158.750 (6.250)	187.3 (7.37)

• For other dimensions, refer to "Foot Mtg.".

Foot Mtg.:50150T-**-L-RL-40/4080/4090

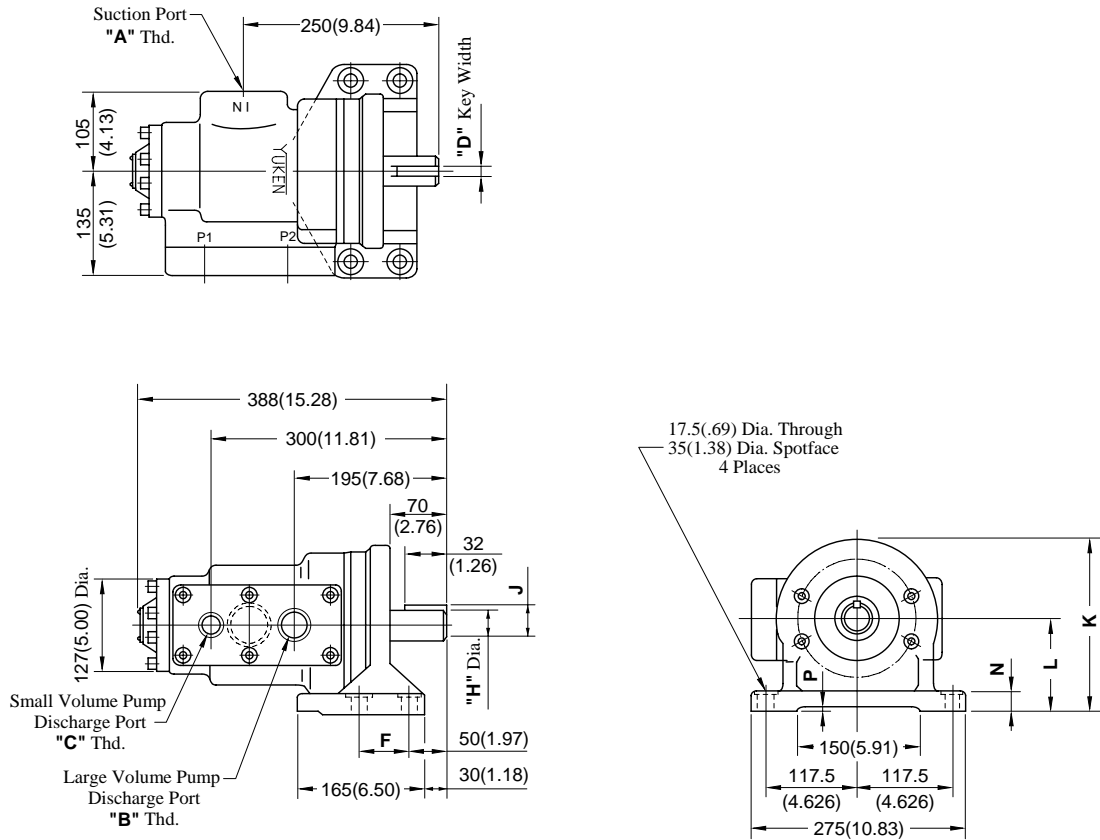

Model Numbers	"A" Thd.	"B" Thd.	"C" Thd.	Dimensions mm (Inches)								
				D	E	E	H	J	K	L	N	P
50150T-**-L-RL-40	Rc 2	Rc 1-1/4	Rc 3/4	10.000 (.3937) 9.964 (.3923)	50 (1.97)	64 (2.520)	38.000 (1.4961) 37.975 (1.4951)	42.000 (1.654) 41.839 (1.647)	220 (8.66)	120 (4.72)	25 (.98)	3 (.12)
50150T-**-L-RL-4080	2 BSP.F	1-1/4 BSP.F	3/4 BSP.F	9.550 (.3760)	57 (2.24)	63.5 (2.500)	38.075 (1.4990) 38.050 (1.4980)	42.225 (1.662) 42.075 (1.656)	220.5 (8.68)	120.7 (4.75)	25.7 (1.01)	3.7 (.15)
50150T-**-L-RL-4090	2 NPT	1-1/4 NPT	3/4 NPT	9.525 (.3750)								

DIMENSIONS IN
MILLIMETRES (INCHES)

Flange Mtg.:50150T-**-F-RL-40/4080/4090

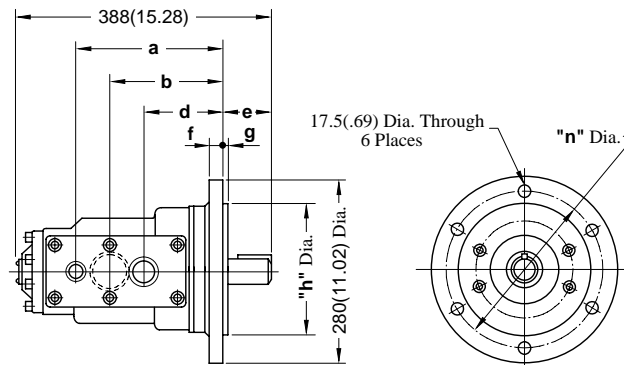

Model Numbers	Dimensions mm (Inches)							
	a	b	d	e	f	g	h	n
50150T-**-F-RL-40	225 (8.86)	175 (6.89)	120 (4.72)	75 (2.95)	22 (.87)	5 (.20)	203.000 (7.992) 202.954 (7.990)	241 (9.49)
50150T-**-F-RL-4080	224 (8.82)	174 (6.85)	119 (4.69)	76 (2.99)	21 (.83)	6.5 (.26)	203.200 (8.000) 203.128 (7.997)	241.3 (9.50)

• For other dimensions, refer to "Foot Mtg.".

Foot Mtg.:150150T-**-L-RL-20/2080/2090

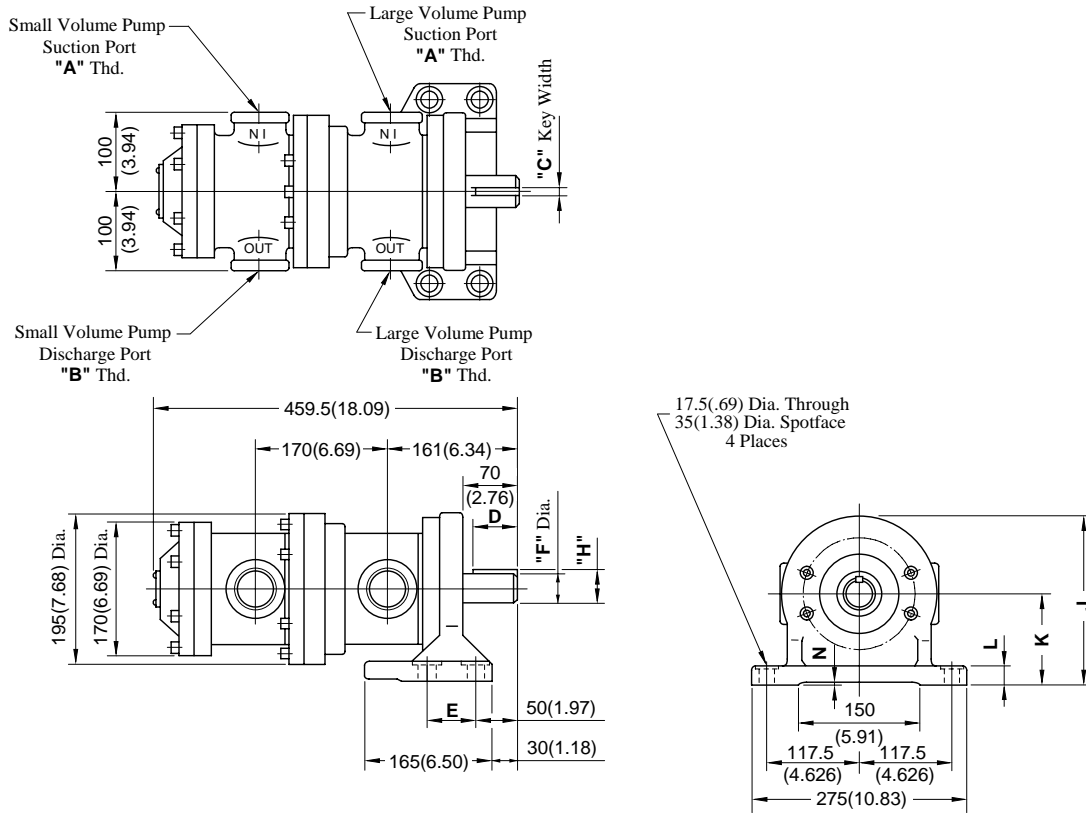

Model Numbers	"A" Thd.	"B" Thd.	Dimensions mm (Inches)								
			C	D	E	F	H	J	K	L	N
150150T-**-L-RL-20	Rc 1-1/2	Rc 1-1/4	10.000 (.3937) 9.964 (.3923)	56 (2.20)	64 (2.520)	38.000 (1.4961) 37.975 (1.4951)	41.000 (1.614) 40.685 (1.602)	220 (8.66)	120 (4.72)	25 (.98)	3 (.12)
150150T-**-L-RL-2080	1-1/2 BSP.F	1-1/4 BSP.F	9.550 (.3760)	55	63.5	38.075 (1.4990)	42.225 (1.662)	220.5	120.7	25.7	3.7
150150T-**-L-RL-2090	1-1/2 NPT	1-1/4 NPT	9.525 (.3750)	(2.17)	(2.500)	38.050 (1.4980)	42.075 (1.656)	(8.68)	(4.75)	(1.01)	(.15)

DIMENSIONS IN
MILLIMETRES (INCHES)

Flange Mtg.:150150T-**-F-RL-20/2080/2090

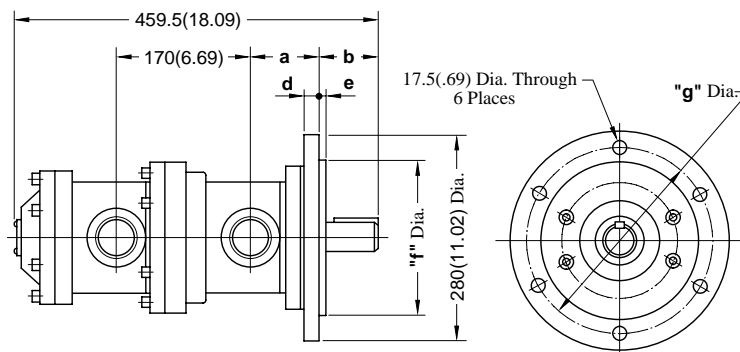

Model Numbers	Dimensions mm (Inches)					
	a	b	d	e	f	g
150150T-**-F-RL-20	86 (3.39)	75 (2.95)	22 (.87)	5 (.20)	203.000 (7.992) 202.954 (7.990)	241 (9.49)
150150T-**-F-RL-2080	85 (3.35)	76 (2.99)	21 (.83)	6.5 (.26)	203.200 (8.000)	241.3 (9.50)
150150T-**-F-RL-2090					203.128 (7.997)	

• For other dimensions, refer to "Foot Mtg.".

Foot Mtg.: 50150F-**-L-RL-40/4080/4090
150250F-**-L-RL-40/4080/4090

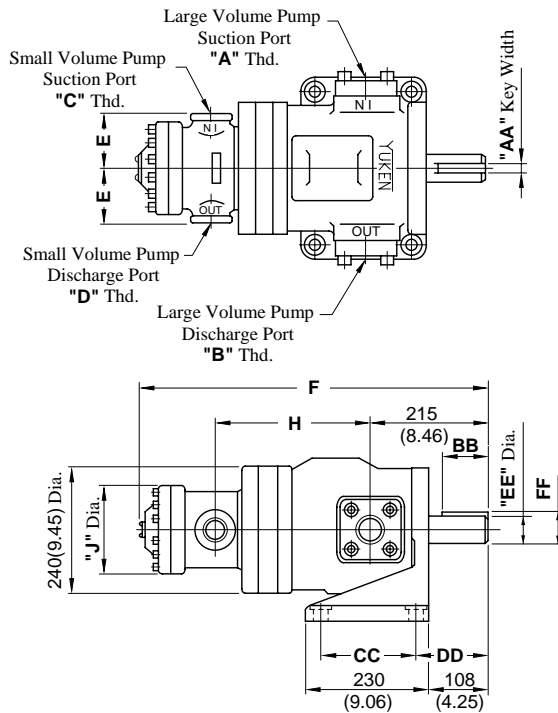

The dimensions of the pipe flange mounting surface for suction and discharge ports are the same as those of "250F" series single pumps. See page 6.

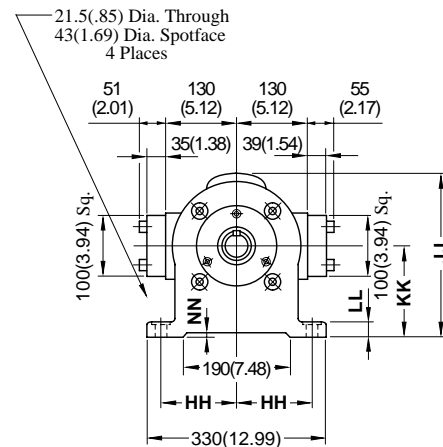

Model Numbers	"A" Thd.	"B" Thd.	"C" Thd.	"D" Thd.	Dimensions mm (Inches)			
					E	F	H	J
50250F-**-L-RL-40	Rc 2	Rc 1-1/2	Rc 1	Rc 3/4	70 (2.76)	562 (22.13)	250 (9.84)	125 (4.92)
50250F-**-L-RL-4080	2 BSP.F	1-1/2 BSP.F	1 BSP.F	3/4 BSP.F				
50250F-**-L-RL-4090	2 NPT	1-1/2 NPT	1 NPT	3/4 NPT				
150250F-**-L-RL-40	Rc 2	Rc 1-1/2	Rc 1-1/2	Rc 1-1/4	100 (3.94)	620.5 (24.43)	277 (10.91)	170 (6.69)
150250F-**-L-RL-4080	2 BSP.F	1-1/2 BSP.F	1-1/2 BSP.F	1-1/4 BSP.F				
150250F-**-L-RL-4090	2 NPT	1-1/2 NPT	1-1/2 NPT	1-1/4 NPT				

Model Numbers	Dimensions mm (Inches)										
	AA	BB	CC	DD	EE	FF	HH	JJ	KK	LL	NN
50250F/150250F-**-L-RL-40	12.000 (.4724) 11.957 (.4708)	85 (3.35)	180 (7.087)	133 (5.24)	50.000 (1.9685) 49.975 (1.9675)	53.000 (2.087) 52.685 (2.074)	140 (5.512)	305 (12.01)	170 (6.69)	28 (1.10)	5 (.20)
50250F/150250F-**-L-RL-4080	12.700 (.5000)	87.3 (3.44)	177.8 (7.000)	133.4 (5.25)	50.800 (2.0000)	54.900 (2.161)	139.7 (5.500)	306.5 (12.07)	171.5 (6.75)	29.5 (1.16)	6.5 (.26)
50250F/150250F-**-L-RL-4090	12.673 (.4989)				50.770 (1.9988)	54.640 (2.151)					

**DIMENSIONS IN
MILLIMETRES (INCHES)**

Flange Mtg.: 50150F-**-F-RL-40/4080/4090
150250F-**-F-RL-40/4080/4090

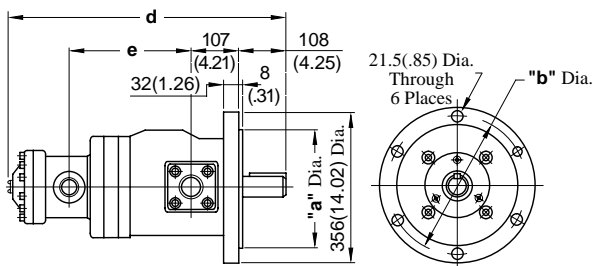

Model Numbers	Dimensions mm (Inches)			
	a	b	d	e
50250F-**-F-RL-40	280.000 (11.024) 279.948 (11.022)	318 (12.52)	562 (22.13)	250 (9.84)
50250F-**-F-RL-4080	279.370 (10.999)	317.5 (12.50)		
50250F-**-F-RL-4090	279.290 (10.996)			
150250F-**-F-RL-40	280.000 (11.024) 279.948 (11.022)	318 (12.52)	620.5 (24.23)	277 (10.91)
150250F-**-F-RL-4080	279.370 (10.999)	317.5 (12.50)		
150250F-**-F-RL-4090	279.290 (10.996)			

• For other dimensions, refer to "Foot Mtg.".

5050T-***-RL-40/4080/4090
50150T-***-RL-40/4080/4090

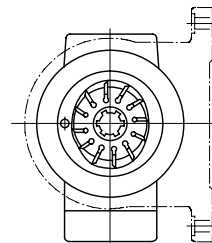
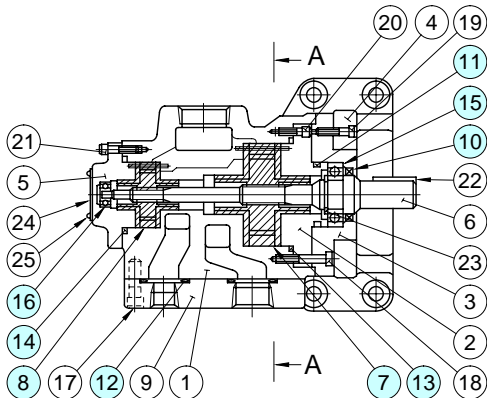

Section A-A

● Seals & Bearings

Item	Name of Parts	Part Numbers		Qty.
		5050T	50150T	
10*	Oil Seal	ISPD 325211	ISPD 406212	1
11*	O-Ring	SO-NA-P52	SO-NA-P62	1
12*	O-Ring	SO-NB-G30	SO-NB-G45	2
13*	O-Ring	SO-NA-A234	SO-NA-A248	1
14*	O-Ring	SO-NA-A234	SO-NA-A234	1
15	Bearing	6305	6207	1
16	Bearing	6200	6200	1

Note: For pumps for phosphate ester type fluids, seals are different from the above. Please contact us.

★ When ordering seals, please specify the seal kit number from the table in the following page.

● Cartridge Kits

Model Numbers	Cartridge Kit Numbers	
	⑧ Small Volume Pump	⑦ Large Volume Pump
5050T-★-■	C50-★-30	C50-■-30
50150T-★-■	C50-★-30	C150-■-40

Notes: 1) ★ and ■ are spaces for nominal displacement figures.

2) Cartridge kits are common with 50T or 150T series single pumps. For details, see page 11.

⚠ CAUTION

When making replacement of seals, bearings or cartridge kits, please do it carefully after reading through the relevant instructions in the Operator's Manual.

150150T-***-RL-20/2080/2090

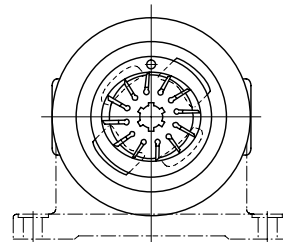
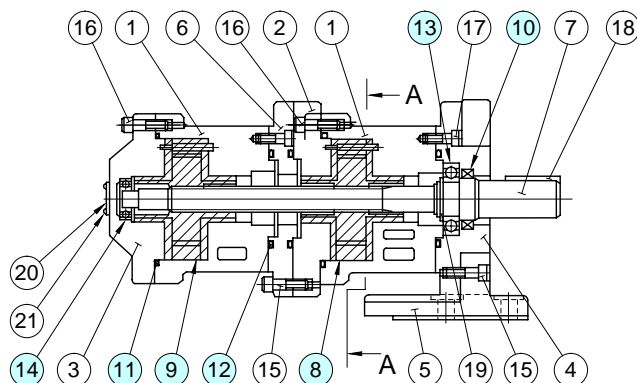

Section A-A

● Seals & Bearings

Item	Name of Parts	Part Numbers	Qty.
10*	Oil Seal	ISPD 406212	1
11*	O-Ring	SO-NA-A248	2
12*	O-Ring	SO-NA-G90	3
13	Bearing	6207	1
14	Bearing	6203	1

Note: For pumps for phosphate ester type fluids, seals are different from the above. Please contact us.

★ When ordering seals, please specify the seal kit number from the table in the following page.

● Cartridge Kits

Model Numbers	Cartridge Kit Numbers	
	⑨ Small Volume Pump	⑧ Large Volume Pump
150150T-★-■	C150-★-40	C150-■-40

Notes: 1) ★ and ■ are spaces for nominal displacement figures.

2) Cartridge kits are common with 150T series single pumps. For details, see page 11.

50250F-***-RL-40/4080/4090
150250F-***-RL-40/4080/4090

⚠ CAUTION

When making replacement of seals, bearings or cartridge kits, please do it carefully after reading through the relevant instructions in the Operator's Manual.

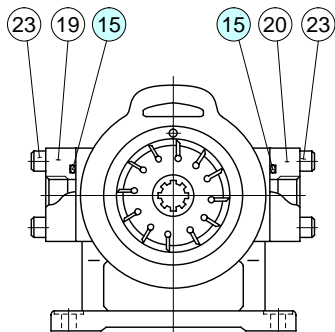

Section A-A

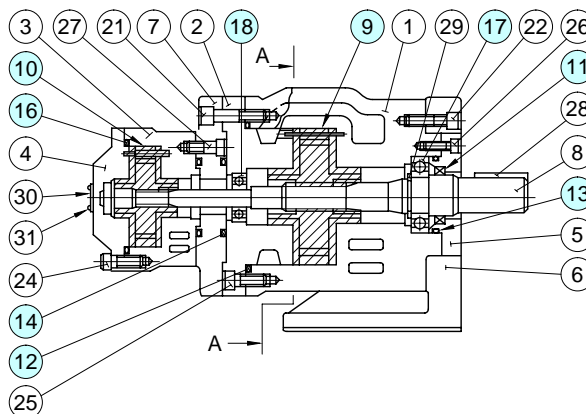

● Cartridge Kits

Model Numbers	Cartridge Kit Numbers	
	⑩ Small Volume Pump	⑨ Large Volume Pump
50250F-★-■	C50-★-30	C250-■-40
150250F-★-■	C150-★-40	C250-■-40

Notes: 1) ★ and ■ are spaces for nominal displacement figures.

2) Cartridge kits are common with single pumps.
For details, see page 11.

● Seals & Bearings

Item	Name of Parts	Part Numbers		Qty.
		50250F	150250F	
11★	Oil Seal	ISPD 527512	ISPD 527512	1
12★	O-Ring	SO-NB-G165	SO-NB-G165	1
13★	O-Ring	SO-NA-G95	SO-NA-G95	1
14★	O-Ring	SO-NB-G50	SO-NB-G90	2
15★	O-Ring	SO-NB-G60	SO-NB-G60	2
16★	O-Ring	SO-NA-A234	SO-NA-A248	1
17	Bearing	6309	6309	1
18	Bearing	6305	6305	1

Note: For pumps for phosphate ester type fluids, seals are different from the above. Please contact us.

★ When ordering seals, please specify the seal kit number from the table below.

● Seal Kit Numbers

Model Numbers	Seal Kit Numbers
5050T-***-RL-40/4080/4090	KS-5050T-40
50150T-***-RL-40/4080/4090	KS-50150T-40
150150T-***-RL-20/2080/2090	KS-150150T-20
50250F-***-RL-40/4080/4090	KS-50250F-40
150250F-***-RL-40/4080/4090	KS-150250F-40



Specifications

Pump Types	Model Numbers	Max. Operating Pressure MPa (PSI)	Output Flow & Input Power		Start Speed Range r/min		Approx. Mass kg (lbs.)	
			Small Volume Pump	Large Volume Pump	Max.	Min.	Foot Mtg.	Flange Mtg.
Relief-relief Type	5050ST	7 ^{★1} (1020)	Same as Single Pump "50T" (Refer to pages 7 & 8)		2000 ^{★2} ^{★6}	600 ^{★4}	44 (97)	42 (92.6)
	50150ST	7 ^{★1} (1020)	Same as Single Pump "50T" (Refer to pages 7 & 8)	Same as Single Pump "150T" (Refer to pages 8 & 9)	1200 ^{★3}	600 ^{★4}	70 (154)	65 (143)
Relief-unloading Type	5050CT	7 ^{★1} (1020)	Same as Single Pump "50T" (Refer to pages 7 & 8)		2000 ^{★2} ^{★6}	600 ^{★4}	44 (97)	42 (92.6)
	50150CT	7 ^{★1} (1020)	Same as Single Pump "50T" (Refer to pages 7 & 8)	Same as Single Pump "150T" (Refer to pages 8 & 9)	1200 ^{★3}	600 ^{★4}	70 (154)	65 (143)

- ★1. The maximum operating pressure is constant irrespective of fluid types.
- ★2. If nominal displacement 17, 23, 26 or 36 is used, the maximum pump speed is restricted as follows:
 ND. 17,23 1800 r/min
 26 1500 r/min
 36 1200 r/min
- ★3. If large-volume side nominal displacement 94 or 116 is used at a speed above 1000 r/min, restrict the suction pressure to -7 kPa (1.97 in. Hg. Vacuum). (For other models, restrict to -20 kPa (5.9 in. Hg. Vacuum).)
- ★4. If nominal displacement 7 is used on the pump on small-volume side, the minimum speed is restricted to 800 r/min.
- ★5. If nominal displacement 94 or 116 is used, the maximum speed is restricted to 1200 r/min.
- ★6. If phosphate ester type fluids are used, the maximum speed is restricted to 1200 r/min.

Model Number Designation

F-	5050CT	-7	-12	-L	-D	-R	L	-40	*	
Special Seals	Series Number	Small Volume Pump Nominal Displacement cm ³ /rev	Large Volume Pump Nominal Displacement cm ³ /rev	Mounting	Pres. Adj. Range of Unloading Valve MPa (PSI)	Direction of Rotation	Discharge Port Position	Design Number	Design Std.	
F: For phosphate ester type fluids (Omit if not required)	5050ST (Relief-relief Type, Threaded Connections)	7, 12, 17 23, 26, 36	7, 12, 17 23, 26, 36	L: Foot Mtg.	D: 0.5 - 1.0 (73 - 145) E: 1.0 - 3.0 (145 - 435) F: 3.0 - 7.0 (435 - 1020)	(Viewed from Shaft End)	R: Clock-wise ^{★1} (Normal)	L: On Left Hand (Normal)	40	Refer to ^{★2}
	50150ST (Relief-relief Type, Threaded Connections)		48, 61, 75 94, 116						40	
	5050CT (Relief-unloading Type, Threaded Connections)	7, 12, 17 23, 26, 36	7, 12, 17 23, 26, 36	F: Flange Mtg.					40	
	50150CT (Relief-unloading Type, Threaded Connections)		48, 61, 75 94, 116						40	

- ★1. Available to supply pump with anti-clockwise rotation. Consult Yuken for details.
- ★2. Design Standards: None.....Japanese Standard "JIS"
 80.....European Design Standard
 90.....N. American Design Standard

Foot Mtg.:5050ST-**-**-L-RL-40/4080/4090

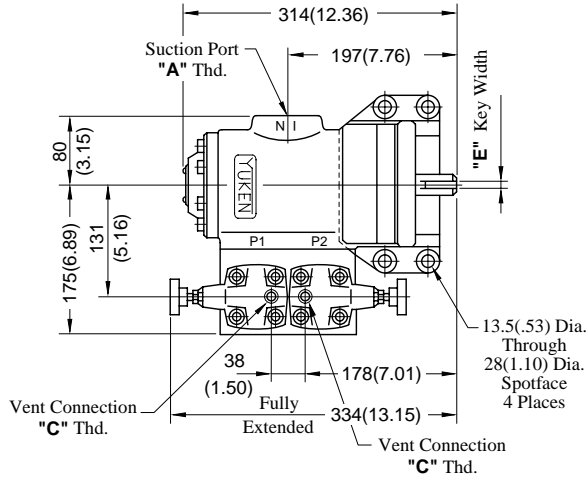

Flange Mtg.:5050ST-**-**-F-RL-40/4080/4090

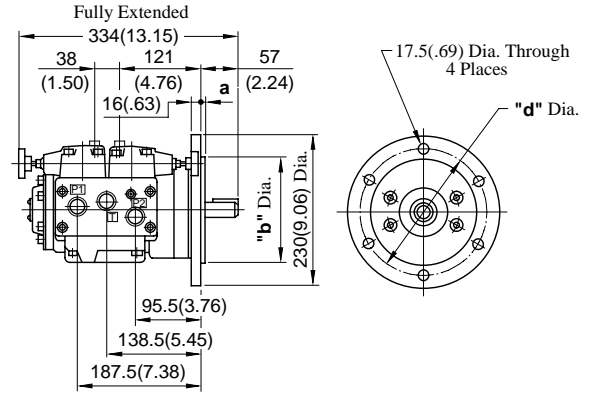

• For other dimensions, refer to "Foot Mtg.".

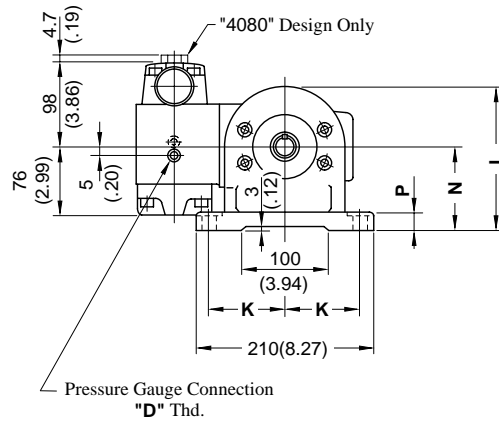
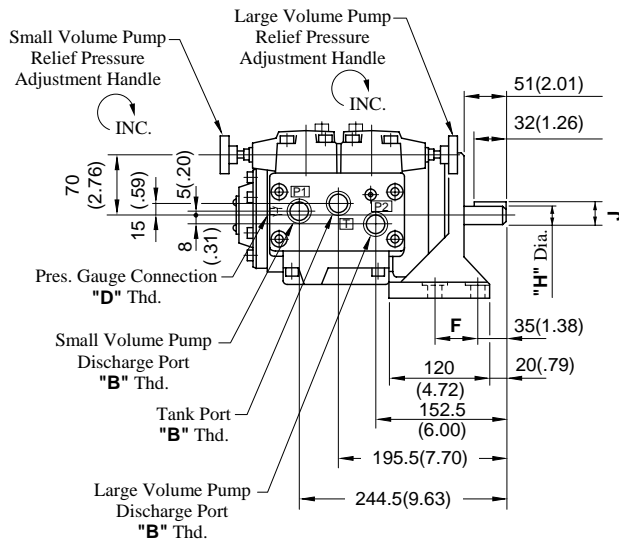

DIMENSIONS IN MILLIMETRES (INCHES)

Model Numbers	"A" Thd.	"B" Thd.	"C" Thd.	"D" Thd.	Dimensions mm (Inches)		
					E	F	H
5050ST-**-**-RL-40	Rc 1-1/2	Rc 3/4	Rc 1/4	Rc 1/4	7.000 (.2756) 6.964 (.2742)	50 (2.008)	25.000 (.9843) 24.979 (.9834)
5050ST-**-**-RL-4080	1-1/2 BSP.F	3/4 BSP.F	1/4 BSP.F	1/4 BSP.Tr	4.760 (.1874)	50.8 (2.000)	25.370 (.9988) 25.349 (.9980)
5050ST-**-**-RL-4090	1-1/2 NPT	3/4 NPT	1/4 NPT	1/4 NPT	4.730 (.1862)		

Model Numbers	Dimensions mm (Inches)							
	J	K	L	N	P	a	b	d
5050ST-**-**-RL-40	28.000 (1.102) 27.743 (1.092)	90 (3.543)	167 (3.543)	95 (3.74)	20 (.79)	6 (.24)	160.000 (6.299) 159.960 (6.298)	190 (7.48)
5050ST-**-**-RL-4080	27.370 (1.078)	88.9 (3.500)	167.3 (6.59)	95.25 (3.75)	20.3 (.80)	6.5 (.26)	158.750 (6.250) 158.674 (6.247)	187.3 (7.37)
5050ST-**-**-RL-4090	27.191 (1.071)							

Foot Mtg.:50150ST-**-**-L-RL-40/4080/4090

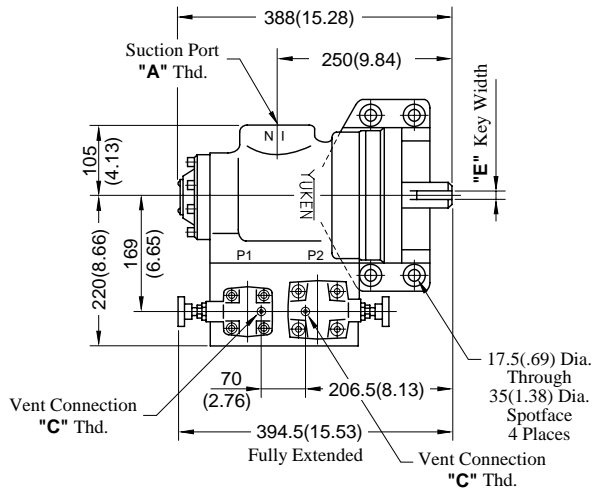

Flange Mtg.:50150ST-**-**-F-RL-40/4080/4090

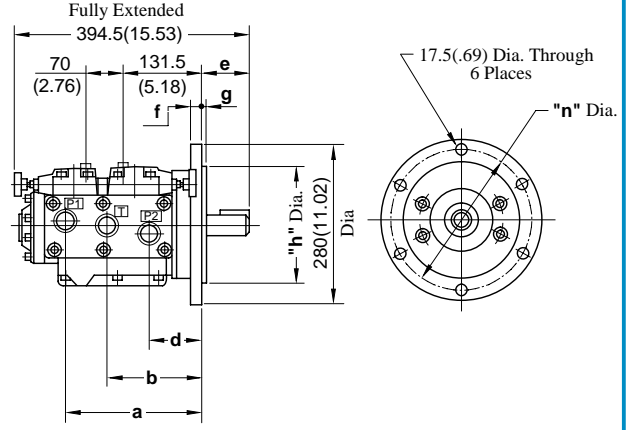

• For other dimensions, refer to "Foot Mtg.".

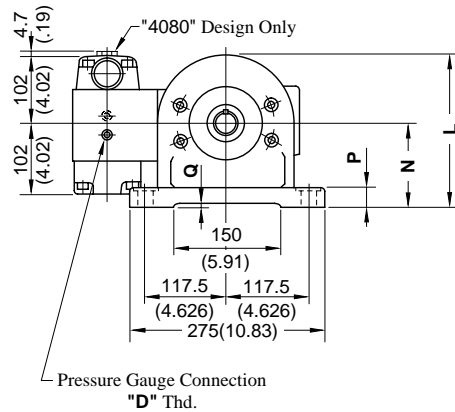
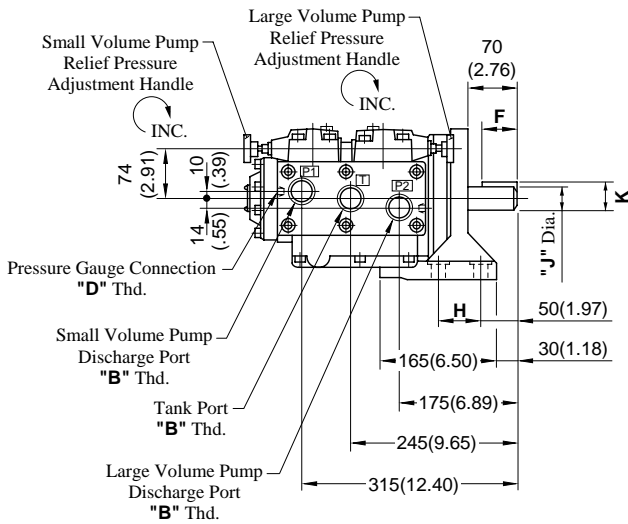

**DIMENSIONS IN
MILLIMETRES (INCHES)**

Model Numbers	"A" Thd.	"B" Thd.	"C" Thd.	"D" Thd.	Dimensions mm (Inches)				
					E	F	H	J	K
50150ST-**-**-RL-40	Rc 2	Rc 1-1/4	Rc 1/4	Rc 1/4	10.000 (.3937) 9.964 (.3923)	50 (1.97)	64 (2.520)	38.000 (1.4961) 37.975 (1.4951)	42.000 (1.654) 41.839 (1.647)
50150ST-**-**-RL-4080	2 BSP.F	1-1/4 BSP.F	1/4 BSP.F	1/4 BSP.Tr	9.550 (.3760)	57 (2.24)	63.5 (2.500)	38.075 (1.4990)	42.225 (1.662)
50150ST-**-**-RL-4090	2 NPT	1-1/4 NPT	1/4 NPT	1/4 NPT	9.525 (.3750)			38.050 (1.4980)	42.075 (1.656)

Model Numbers	Dimensions mm (Inches)											
	L	N	P	Q	a	b	d	e	f	g	h	n
50150ST-**-**-RL-40	220 (8.66)	120 (4.72)	25 (.98)	3 (.12)	225 (8.86)	175 (6.89)	120 (4.72)	75 (2.95)	22 (.87)	5 (.20)	203.000 (7.992) 202.954 (7.990)	241 (9.49)
50150ST-**-**-RL-4080	220.5 (8.68)	120.7 (4.75)	25.7 (1.01)	3.7 (.15)	224 (8.82)	174 (6.85)	119 (4.69)	76 (2.99)	21 (.83)	6.5 (.26)	203.200 (8.000) 203.128 (7.997)	241.3 (9.50)

Foot Mtg.:
5050CT-**-*-L-*-RL-40/4080/4090

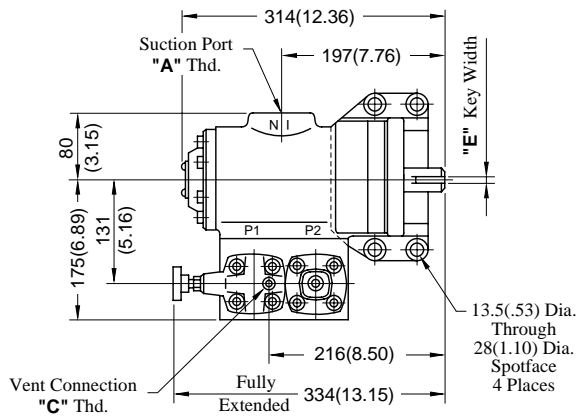

Flange Mtg.:
5050CT-**-*-F-*-RL-40/4080/4090

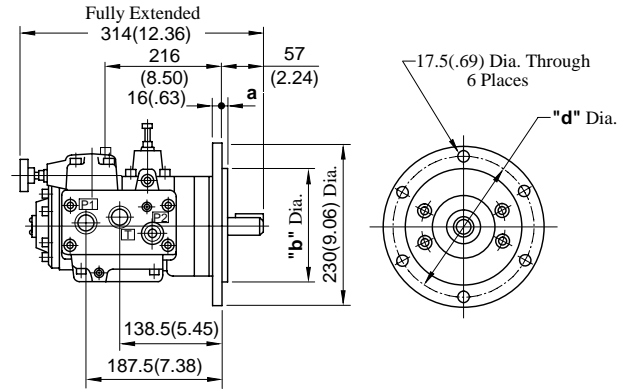

• For other dimensions, refer to "Foot Mtg.".

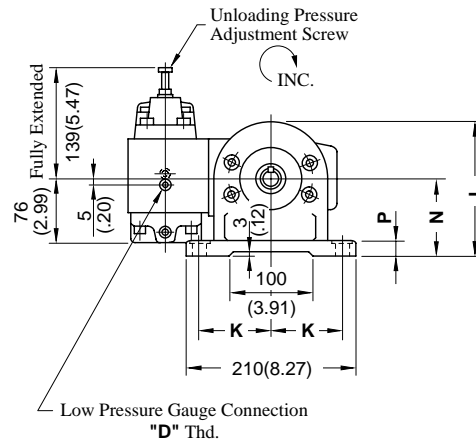
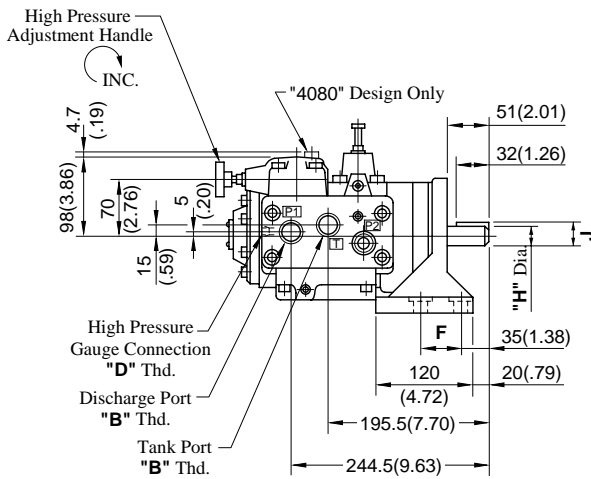

**DIMENSIONS IN
MILLIMETRES (INCHES)**

Model Numbers	"A" Thd.	"B" Thd.	"C" Thd.	"D" Thd.	Dimensions mm (Inches)		
					E	F	H
5050CT-**-*-RL-40	Rc 1-1/2	Rc 3/4	Rc 1/4	Rc 1/4	7.000 (.2756) 6.964 (.2742)	50 (1.969)	25.000 (.9843) 24.979 (.9834)
5050CT-**-*-RL-4080	1-1/2 BSP.F	3/4 BSP.F	1/4 BSP.F	1/4 BSP.Tr	4.760 (.1874)	50.8	25.370 (.9988)
5050CT-**-*-RL-4090	1-1/2 NPT	3/4 NPT	1/4 NPT	1/4 NPT	4.730 (.1862)	(2.000)	25.349 (.9980)

Model Numbers	Dimensions mm (Inches)							
	J	K	L	N	P	a	b	c
5050CT-**-*-RL-40	28.000 (1.102) 27.743 (1.092)	90 (3.543)	167 (6.57)	95 (3.74)	20 (.79)	6 (.24)	160.000 (6.299) 159.960 (6.298)	190 (7.48)
5050CT-**-*-RL-4080	27.370 (1.078)	88.9	167.3	95.25	20.3	6.5	158.750 (6.250)	187.3
5050CT-**-*-RL-4090	27.191 (1.071)	(3.500)	(6.59)	(3.75)	(.80)	(.26)	158.674 (6.247)	(7.37)

Foot Mtg.:

50150CT-***-L*-RL-40/4080/4090

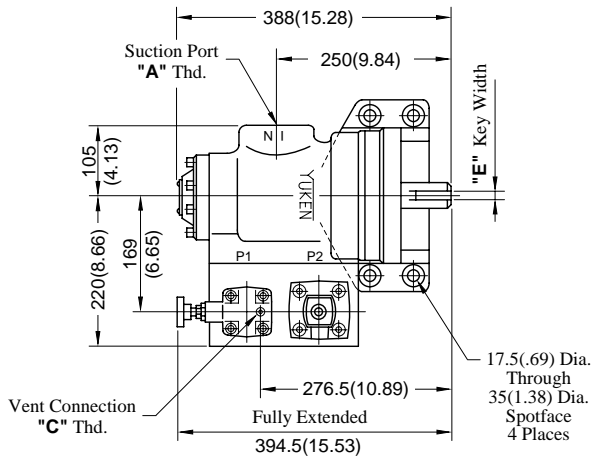

Flange Mtg.:

50150CT-***-F*-RL-40/4080/4090

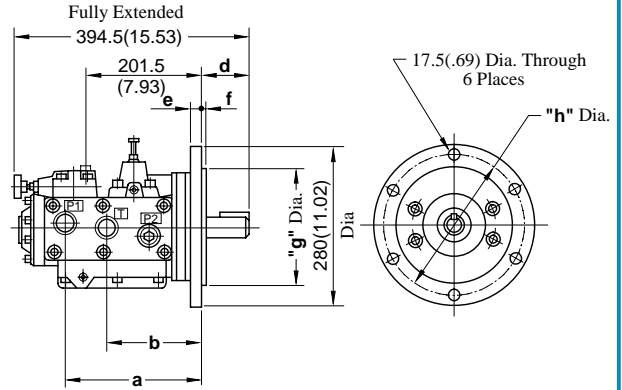

• For other dimensions, refer to "Foot Mtg."

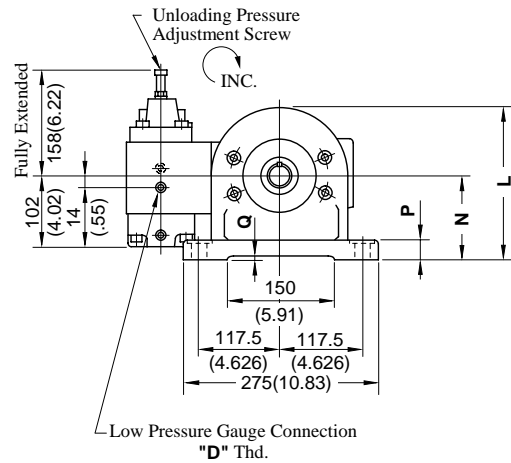
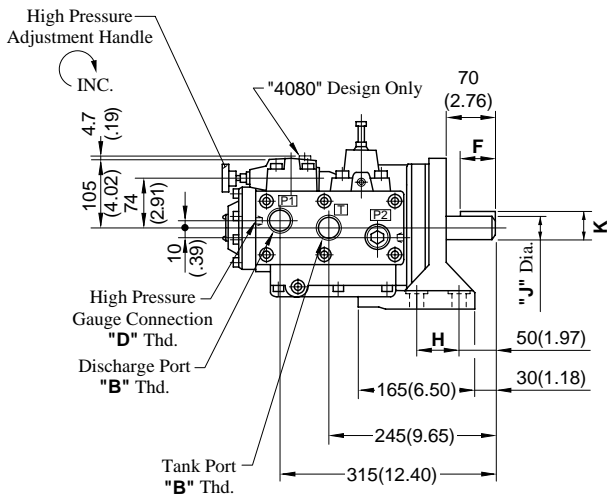

**DIMENSIONS IN
MILLIMETRES (INCHES)**

Model Numbers	"A" Thd.	"B" Thd.	"C" Thd.	"D" Thd.	Dimensions mm (Inches)				
					E	F	H	J	K
50150CT-***-L*-RL-40	Rc 2	Rc 1-1/4	Rc 1/4	Rc 1/4	10.000 (.3937) 9.964 (.3923)	50 (1.97)	64 (2.520)	38.000 (1.4961) 37.975 (1.4951)	42.000 (1.654) 41.839 (1.647)
50150CT-***-L*-RL-4080	2 BSP.F	1-1/4 BSP.F	1/4 BSP.F	1/4 BSP.Tr	9.550 (.3760)	57 (2.24)	63.5 (2.500)	38.075 (1.4990) 38.050 (1.4980)	42.225 (1.662) 42.075 (1.656)
50150CT-***-L*-RL-4090	2 NPT	1-1/4 NPT	1/4 NPT	1/4 NPT	9.525 (.3750)				

Model Numbers	Dimensions mm (Inches)										
	L	N	P	Q	a	b	d	e	f	g	h
50150CT-***-L*-RL-40	220 (8.66)	120 (4.72)	25 (.98)	3 (.12)	225 (8.86)	175 (6.89)	75 (2.95)	22 (.87)	5 (.20)	203.000 (7.992) 202.954 (7.990)	241 (9.49)
50150CT-***-L*-RL-4080	220.5 (8.68)	120.7 (4.75)	25.7 (1.01)	3.7 (.15)	224 (8.82)	174 (6.85)	76 (2.99)	21 (.83)	6.5 (.26)	203.200 (8.000) 203.128 (7.997)	241.3 (9.50)
50150CT-***-L*-RL-4090											

Spare Parts List

⚠ CAUTION

When making replacement of seals, bearings or cartridge kits, please do it carefully after reading through the relevant instructions in the Operator's Manual.

5050ST
50150ST

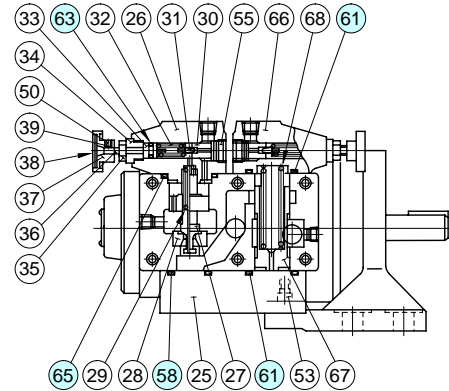
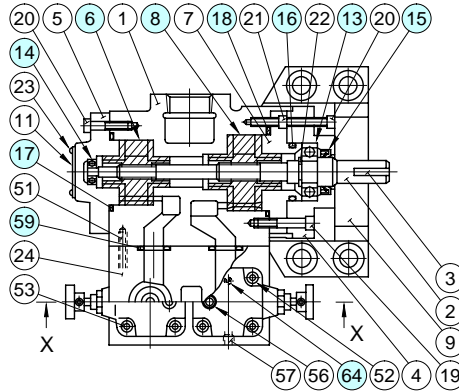

5050CT
50150CT

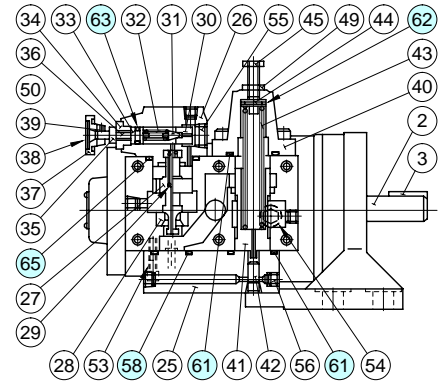
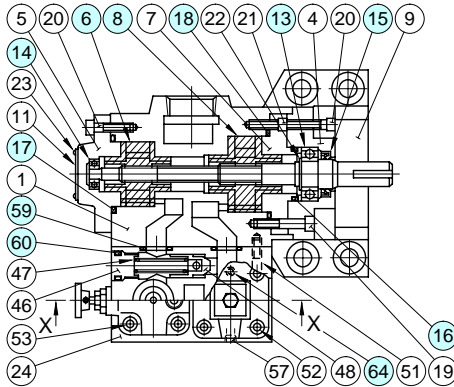

● Seals & Bearings

Item	Name of Parts	Part Numbers				Qty.	
		5050ST	50150ST	5050CT	50150CT	5050ST 50150ST	5050CT 50150CT
15*	Oil Seal	ISPD 325211	ISPD 406212	ISPD 325211	ISPD 406212	1	1
16*	O-Ring	SO-NA-P52	SO-NA-P62	SO-NA-P52	SO-NA-P62	1	1
17*	O-Ring	SO-NA-A234	SO-NA-A234	SO-NA-A234	SO-NA-A234	1	1
18*	O-Ring	SO-NA-A234	SO-NA-A248	SO-NA-A234	SO-NA-A248	1	1
58*	O-Ring	SO-NB-G40	SO-NB-P48	SO-NB-G40	SO-NB-P48	1	1
59*	O-Ring	SO-NB-P28	SO-NB-P40	SO-NB-P28	SO-NB-P40	2	2
60*	O-Ring	—	—	SO-NB-P24	SO-NB-P39	—	1
61*	O-Ring	SO-NB-G30	SO-NB-P36	SO-NB-G30	SO-NB-P36	2	2
62*	O-Ring	—	—	SO-NA-P15	SO-NA-P20	—	1
63*	O-Ring	SO-NA-P9	SO-NA-P9	SO-NA-P9	SO-NA-P9	2	1
64*	O-Ring	SO-NB-P6	SO-NB-P6	SO-NB-P6	SO-NB-P6	1	2
65*	O-Ring	SO-NB-G40	SO-NB-G40	SO-NB-G40	SO-NB-G40	1	1
13	Bearing	6305	6207	6305	6207	1	1
14	Bearing	6200	6200	6200	6200	1	1

● Cartridge Kits

Model Numbers	Cartridge Kit Numbers	
	⑥ Small Volume Pump	⑧ Large Volume Pump
5050 $\frac{5}{8}$ T-★-■	C50-★-30	C50-■-30
50150 $\frac{5}{8}$ T-★-■	C50-★-30	C150-■-40

Notes: 1) ★ and ■ are spaces for nominal displacement figures.
2) Cartridge kits are common with single pumps.
For details, see page 11.

★ When ordering seals, please specify the seal kit number from the table below.

● Seal Kits

Model Numbers	Seal Kit No.
5050ST-***-RL-40*	KS-5050ST-40
50150ST-***-RL-40*	KS-50150ST-40
5050CT-***-RL-40*	KS-5050CT-40
50150CT-***-RL-40*	KS-50150CT-40

Up to 21 MPa (3050 PSI), 237 cm³/rev (14.46 CU.IN./rev)

B

■ Single Pumps

These pumps are of high pressure and high performance, which have been developed especially for low noise operation. To comply with a variety of applications including injection moulding machines, PV2R series single pumps provide the output flow of such a wide range as from 5.8 to 237 cm³/rev (.354 to 14.46 cu.in./rev). The integral driving parts of the pumps are combined into a kit form and available for supply as a cartridge kit. Therefore, the replacement of the driving parts can be done easily.

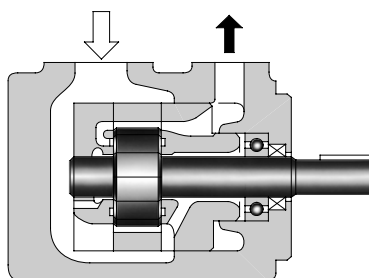

Graphic Symbol

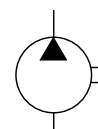

■ Double Pumps

These double pumps consist of two PV2R series single pumps combined in tandem within a single housing and driven by a common shaft. A single suction port and two discharge ports are provided so that the output flow can be supplied to separate circuits.

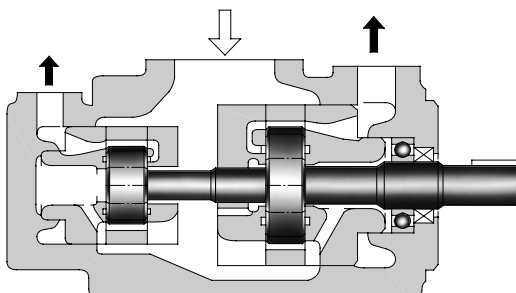
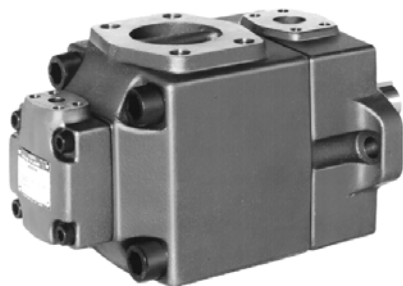

Graphic Symbol

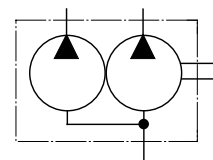

■ Hydraulic Fluids

1. Type of hydraulic fluids

Any type of hydraulic fluids listed in the Table 1 below can be used. However, the specifications of the pumps such as maximum pressure and maximum pump speed may be changed according to the type of hydraulic fluids to be used. For details, please refer to the specifications of the pump concerned.

● Hydraulic fluids

(Table 1)

Type of Fluids	"PV2R" Series Single Pumps "PV2R" Series Double Pumps
Petroleum Base Oils	Use anti-wear type oils or R & O (Rust and Oxidation inhibitor) type oils (equivalent to ISO VG32 or 46).
Synthetic Fluids	Use phosphate ester type fluids. When phosphate ester type fluid is used, prefix "F-" to the model number because the special seals (fluororubber) are required to be used.
Water Containing Fluids	Water-Glycols Standard pumps can be used without conditions. However, if any type other than those in Table 2 is used, the maximum operating pressure is limited.
	Water in Oil Emulsions Standard pumps can be used without conditions.

● Anti-wear type water-glycols

(Table 2)

Fluid Manufacturer	Commercial Trade Name
Mobile	Mobil Hydrofluid HFC 46 Mobil Nybac FR 200 D
JAPAN ENERGY CORP.	JOMO Hydria
NIPPON OIL CO., LTD	HYRAND FRX 46
Showa Shell Sekiyu K. K.	Irus Fluid C G-W Fluid 46
MATSUMURA OIL RESEARCH CORP.	HYDOL HAW
COSMO OIL CO., LTD.	COSMO FLUID HQ 46 COSMO FLUID GS 46

2. Fluid viscosity and temperature

Use the hydraulic fluids which satisfy the recommended viscosity and oil temperature given in the Table 3 below. However, please note that if any of the pumps listed in the table 4 is started at low speed, the maximum fluid viscosity is limited.

● Fluid viscosity and temperature

(Table 3)

Fluid	Temperature °C (°F)	Viscosity mm ² /s(SSU)
Petroleum Base Oils	0-70 (32-158)	20-400 (100-1800)
Phosphate Esters		
Water Glycols	0-50 (32-122)	
Water in Oil Emulsions	5-50 (41-122)	

● Maximum viscosity for low start-up speed

(Table 4)

Pump Type	Start-up Speed r/min	Max. Viscosity mm ² /s (SSU)
PV2R1 PV2R12 PV2R13 PV2R14	750	100 (455)
	950	200 (910)
PV2R2 PV2R23 PV2R24	600	100 (455)
	950	200 (910)

3. Control of contamination

Contamination of hydraulic fluids results in pump failures and reduced pump lives. Carry out sufficient contamination control for hydraulic fluids and keep contamination level within NAS class 12. Also, use a 100 μm (150-mesh) tank filter on the suction side, more than 50 mm (2 in.) away from the tank bottom.

■ Instructions

1. Alignment of shaft

Employ a flexible coupling whenever possible, and avoid any stress from bending or thrust. Maximum permissible misalignment is less than 0.1 mm (.004 inches) TIR and maximum permissible misangular is less than 0.2°.

2. Suction pressures

Set the suction pressure at pump inlet port at the value given in the table below. Furthermore, use the pipes in the suction side having the diameter as indicated on the installation drawings. In case where the pump is installed on the tank or at the position higher than the tank top cover, the height of the suction port of the pump should be less than 1 metre (3.3 ft.) from the oil level {less than 0.8 metre (2.6 ft.) in case of using phosphate ester fluids or water containing fluids}.

Pump Type		Suction Pressure		
		Minimum		Maximum
		Petroleum base oil	Phosphate ester type fluid Water containing fluid	
Single Pumps	PV2R1 PV2R2	-20 kPa (5.9 in. Hg Vacuum)	-16 kPa (4.7 in. Hg Vacuum)	+30 kPa (+4.3 PSIG)
	PV2R3 PV2R4	-20 kPa* (5.9 in. Hg Vacuum)*		
Double Pumps	PV2R12	-20 kPa (5.9 in. Hg Vacuum)		
	PV2R13 PV2R23 PV2R33 PV2R14 PV2R24 PV2R34	-20 kPa* (5.9 in. Hg Vacuum)*		

★In relation to the rotating speed of the pump, the minimum suction pressure may be restricted for a certain nominal displacement. For details, please refer to the specifications of the pump concerned.

3. Precautions at starting

At an initial operation or at an operation after a long rest, the pump may have difficulty in sucking up fluid. In such cases, an air bleed valve should be installed beforehand on the discharge side (model No. ST1004-*-10*, Catalogue No. Pub. EC-3001.), or discharge air by slightly slackening the connection on the discharge side. At starting, operate the pump intermittently as far as possible with no load.

For fluid viscosity at starting, see the item of "Hydraulic Fluids".

4. Other precautions

If a pump is used at speed below 1200 r/min, install the pump with the suction port upside so that the pump can suck up fluid easily at starting.

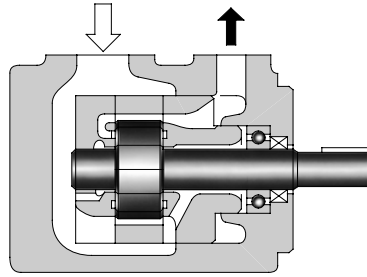
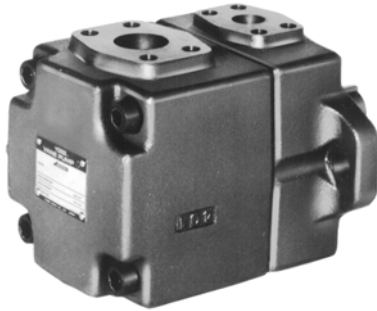

Graphic Symbol

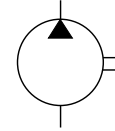

Model Number Designation

F-	PV2R1	-6	-L	-R	A	A	-40	-*
Special Seals	Series Number	Nominal Displacement cm ³ /rev	Type of Mounting	Shaft Rotation	Discharge Port Position	Suction Port Position	Design Number	Design Standards
F: For phosphate ester type fluids (Omit if not required)	PV2R1	6, 8 10, 12 14, 17 19, 23 25, 31	L: Foot Mounting	(Viewed from Shaft End) R: Clockwise ★1 (Normal)	A: Upwards (Normal)	A: Upwards (Normal)	40	Refer to ★2
	PV2R2	41, 47 53, 59 65	F: Flange Mounting				40	
	PV2R3	76, 94 116					30	
	PV2R4	136, 153 184, 200 237					30	

★1. Available to supply pump with anti-clockwise rotation. Consult Yuken for details.
 ★2. Design Standards: None.....Japanese Standard "JIS"
 80.....European Design Standard
 90.....N. American Design Standard

Pipe Flange Kits

Pipe flange kits are available. When ordering, specify the kit number from the table below.

Pump Model Numbers	Name of Port	Pipe Flange Kit Numbers						
		Threaded Connection			Socket Welding*		Butt Welding	
		Japanese Standard "JIS"	European Design Standard	N. American Design Standard	Japanese Standard "JIS" European Design Standard	N. American Design Standard	Japanese Standard "JIS" European Design Standard	N. American Design Standard
PV2R1	Suction	F5-08-A-10	F5-08-A-1080	F5-08-A-1090	F5-08-B-10	F5-08-B-1090	F5-08-C-10	F5-08-C-1090
	Discharge	F5-04-A-10	F5-04-A-1080	F5-04-A-1090	F5-04-B-10	F5-04-B-1090	F5-04-C-10	F5-04-C-1090
PV2R2	Suction	F5-10-A-10	F5-10-A-1080	F5-10-A-1090	F5-10-B-10	F5-10-B-1090	F5-10-C-10	F5-10-C-1090
	Discharge	F5-06-A-10	F5-06-A-1080	F5-06-A-1090	F5-06-B-10	F5-06-B-1090	F5-06-C-10	F5-06-C-1090
PV2R3	Suction	F5-16-A-10	F5-16-A-1080	F5-16-A-1090	F5-16-B-10	F5-16-B-1090	F5-16-C-10	F5-16-C-1090
	Discharge	F5-10-A-10	F5-10-A-1080	F5-10-A-1090	F5-10-B-10	F5-10-B-1090	F5-10-C-10	F5-10-C-1090
PV2R4	Suction	F5-24-A-10	—	—	F5-24-B-10	F5-24-B-1090	F5-24-C-10	F5-24-C-1090
	Discharge	F5-12-A-10	F5-12-A-1080	F5-12-A-1090	F5-12-B-10	F5-12-B-1090	F5-12-C-10	F5-12-C-1090

★In case of using socket welding flanges, there is a case where the operating pressure should be set lower than the normal because of strength of the flanges. Therefore, please pay cautious attention to the operating pressure when the socket welding flanges are used.

Notes: Special seals (Viton seals) are required when phosphate ester type fluids are used. (Prefix "F-" to the pipe flange kit number when ordering.)

●Details of the pipe flange kits are given in the Catalogue No. Pub. EC-3001.

Specifications

Model Numbers	Geometric Displacement cm ³ /rev (cu.in./rev)	Max. Operating Pressure MPa (PSI)						Output Flow & Input Power	Shaft Speed Range r/min	
		Petroleum Base Oils		Water Containing Fluids			Synthetic Fluids		Max.	Min.
		Anti-Wear Type	R & O Type	Anti-Wear ^{★1} Type Water Glycols	Water Glycols	Water in Oil Emulsions	Phosphate Esters			
PV2R1-6	5.8 (.354)	21 ^{★6} (3050)	16 (2320)	16 (2320)	7 (1020)	7 (1020)	16 (2320)	Refer to Pages 11-13	1800 (1200) ^{★4}	750 ^{★5}
PV2R1-8	8.0 (.488)									
PV2R1-10	9.4 (.574)									
PV2R1-12	12.2 (.744)									
PV2R1-14	13.7 (.836)									
PV2R1-17	16.6 (1.013)									
PV2R1-19	18.6 (1.135)									
PV2R1-23	22.7 (1.385)									
PV2R1-25	25.3 (1.544)									
PV2R1-31	31.0 (1.892)	16 (2320)								
PV2R2-41	41.3 (2.52)	21 (3050)	14 (2030)	16 (2320)	7 (1020)	7 (1020)	14 (2030)	Refer to Pages 13&14	1800 (1200) ^{★4}	600 ^{★5}
PV2R2-47	47.2 (2.88)									
PV2R2-53	52.5 (3.20)									
PV2R2-59	58.2 (3.55)									
PV2R2-65	64.7 (3.95)									
PV2R3-76	76.4 (4.66)	21 (3050)	14 (2030)	16 (2320)	7 (1020)	7 (1020)	14 (2030)	Refer to Page 15	1800 (1200) ^{★4}	600
PV2R3-94	93.6 (5.71)								1800 ^{★2} (1200) ^{★4}	
PV2R3-116	115.6 (7.05)	16 (2320)								
PV2R4-136	136 (8.30)	17.5 (2540)	14 (2030)	16 (2320)	7 (1020)	7 (1020)	14 (2030)	Refer to Pages 15&16	1800 (1200) ^{★4}	600
PV2R4-153	153 (9.34)									
PV2R4-184	184 (11.23)									
PV2R4-200	201 (12.26)									
PV2R4-237	237 (14.46)								1800 ^{★3} (1200) ^{★4}	

- ★1. For the brands of anti-wear water-glycols , see the item of "Hydraulic Fluids" on page 3.
- ★2. If PV2R3-116 is used at speed above 1700 r/min, the suction pressure is limited to 0 kPa (0 in. Hg.).
- ★3. If PV2R4-237 is used at speed above 1700 r/min, the suction pressure is limited to -13 kPa (3.94 in. Hg. vacuum).
- ★4. If phosphate ester or water containing fluids are used, the maximum speed is limited to 1200 r/min.
- ★5. For starting at low speed, the maximum viscosity is limited. For details, see the item of "Hydraulic Fluids" on page 3.
- ★6. For pressure above 16 MPa (2320 PSI), raise the speed over 1450 r/min.

Mass

Model Numbers	Approx. Mass kg (lbs.)	
	Flange Mtg.	Foot Mtg.
PVR2R1	9.0 (19.8)	11.2 (24.7)
PVR2R2	15.5 (34.2)	19.8 (43.7)
PVR2R3	30.9 (68.1)	40.9 (90.2)
PVR2R4	68.5 (151)	93.5 (206)

Flange Mtg.: PV2R1-*-F-RAA-40/4090

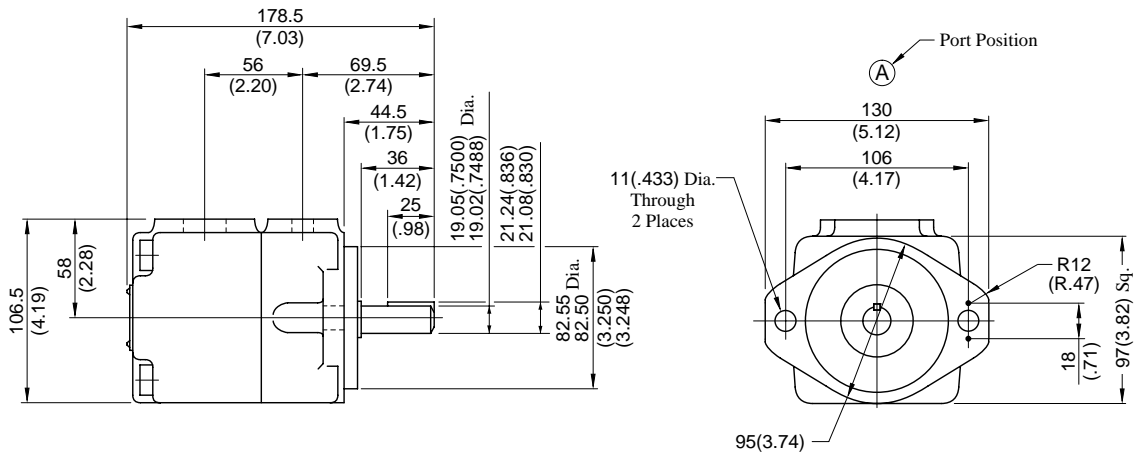
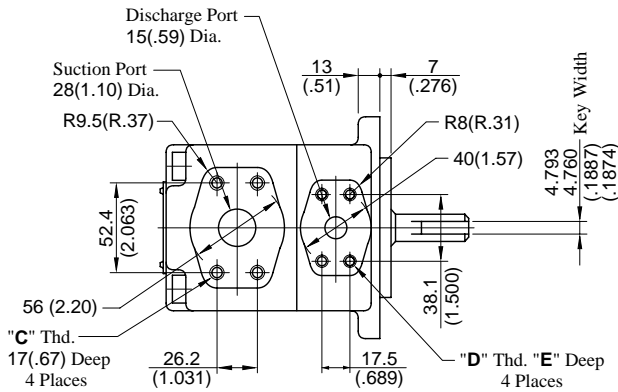

Model Numbers	"C" Thd.	"D" Thd.	E mm (Inches)
PV2R1-*-F-RAA-40	M10	M8	14 (.55)
PV2R1-*-F-RAA-4090	3/8-16 UNC	5/16-18 UNC	16 (.63)

**DIMENSIONS IN
MILLIMETRES (INCHES)**

Foot Mtg.: PV2R1-*-L-RAA-40/4090

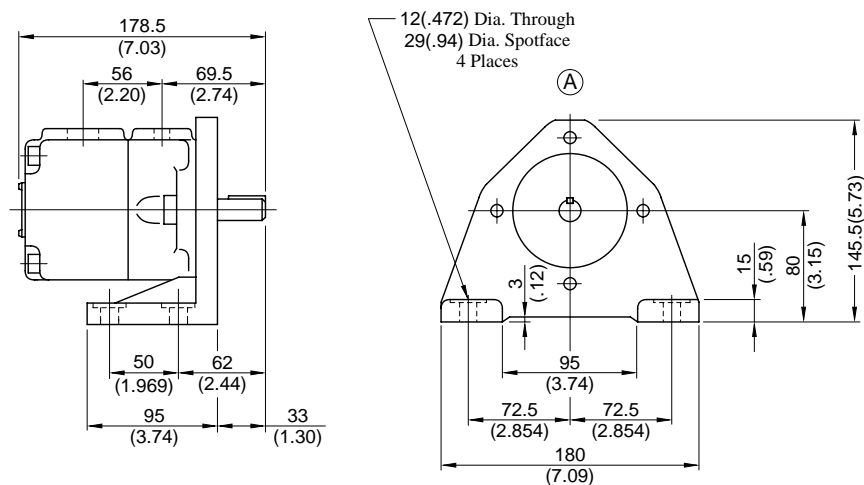

• For other dimensions, refer to "Flange Mtg.".

Flange Mtg.: PV2R2-*-F-RAA-40/4090

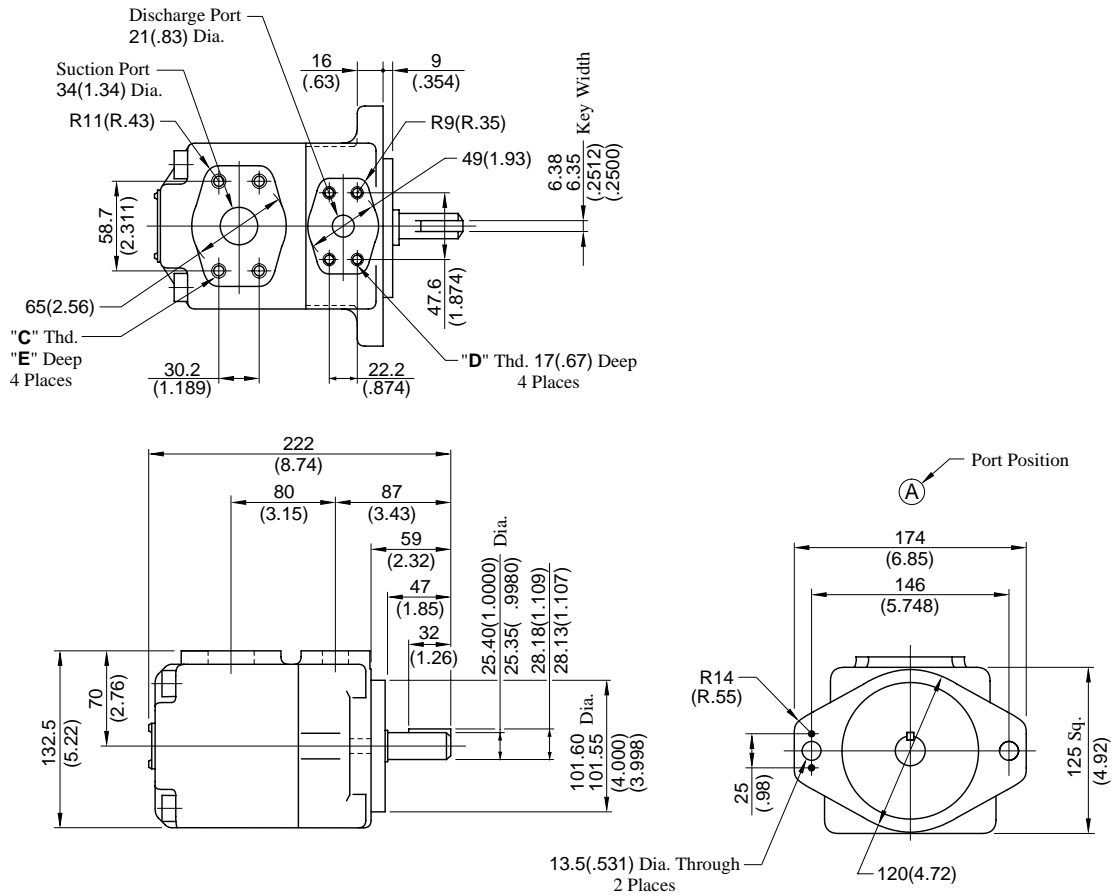

Model Numbers	"C" Thd.	"D" Thd.	E mm (Inches)
PV2R2-*-F-RAA-40	M10	M8	19 (.75)
PV2R2-*-F-RAA-4090	7/16-14 UNC	3/8-16 UNC	20 (.79)

DIMENSIONS IN
MILLIMETRES (INCHES)

Foot Mtg.: PV2R2-*-L-RAA-40/4090

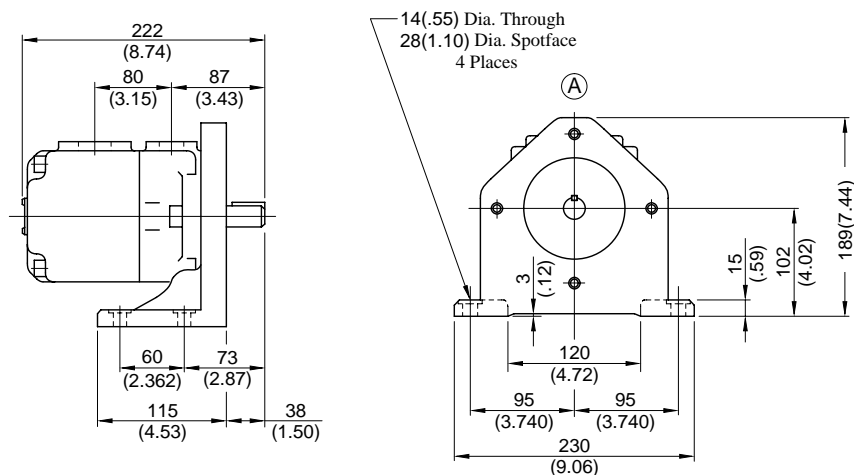

• For other dimensions, refer to "Flange Mtg.".

Flange Mtg.: PV2R3-*-F-RAA-30/3090

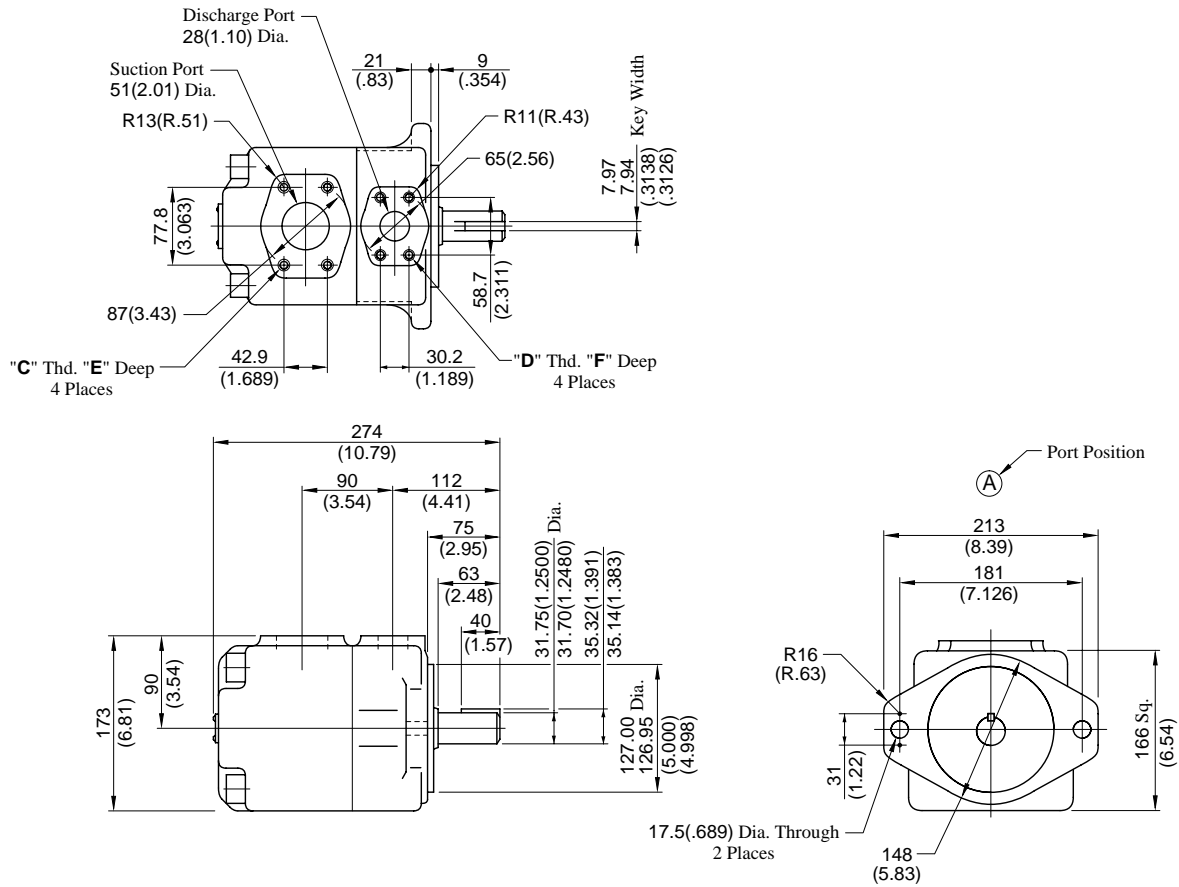

Model Numbers	"C" Thd.	"D" Thd.	Dimensions mm (Inches)	
			E	F
PV2R3-*-F-RAA-30	M12	M10	19 (.75)	19 (.75)
PV2R3-*-F-RAA-3090	1/2-13 UNC	7/16-14 UNC	21 (.83)	20 (.79)

**DIMENSIONS IN
MILLIMETRES (INCHES)**

Foot Mtg.: PV2R3-*-L-RAA-30/3090

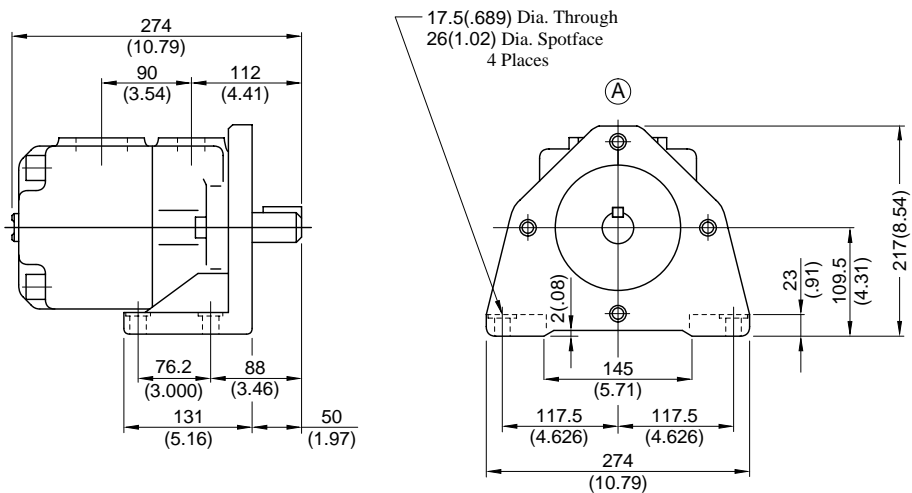

• For other dimensions, refer to "Flange Mtg.".

Flange Mtg.: PV2R4-*-F-RAA-30/3090

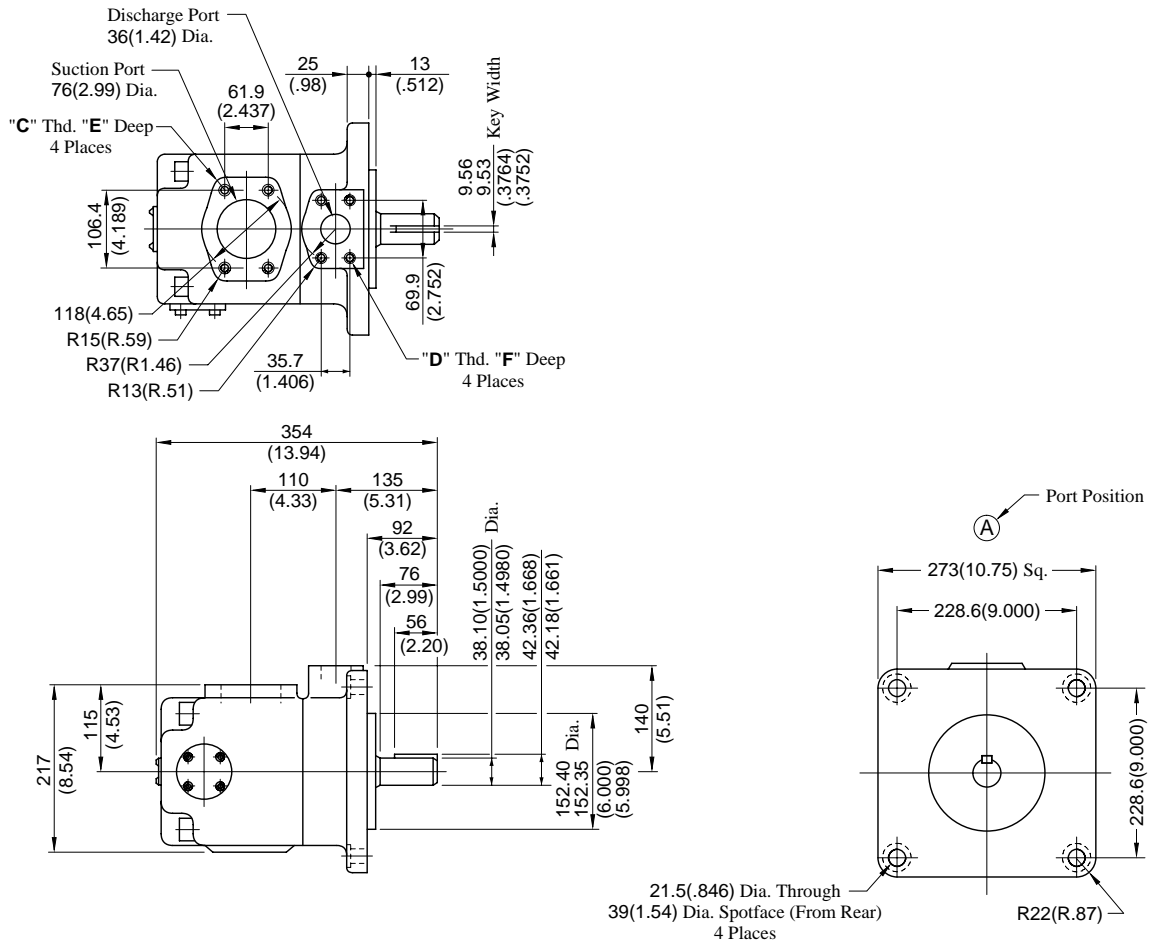

Model Numbers	"C" Thd.	"D" Thd.	Dimensions mm (Inches)	
			E	F
PV2R4-*-F-RAA-30	M16	M12	19 (.75)	19 (.75)
PV2R4-*-F-RAA-3090	1/2-13 UNC	5/8-11 UNC	21 (.83)	21 (.83)

**DIMENSIONS IN
MILLIMETRES (INCHES)**

Foot Mtg.: PV2R4-*-L-RAA-30/3090

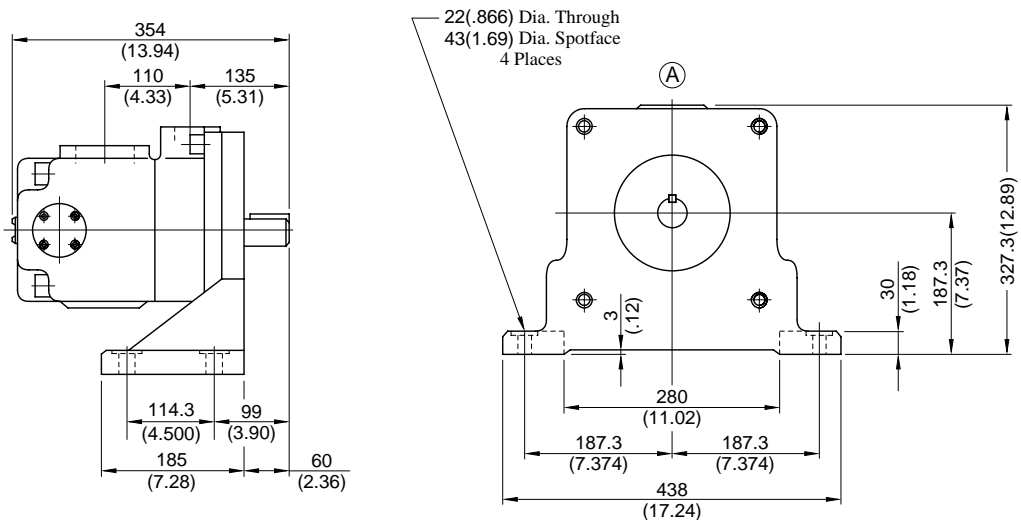

• For other dimensions, refer to "Flange Mtg.".

■ Noise Level

● Measuring conditions

Fluid viscosity : 20 mm²/s (100 SSU)

Measurement point : One metre (3.3 ft.) horizontally away from pump head cover

Back ground noise : 40 dB (A)

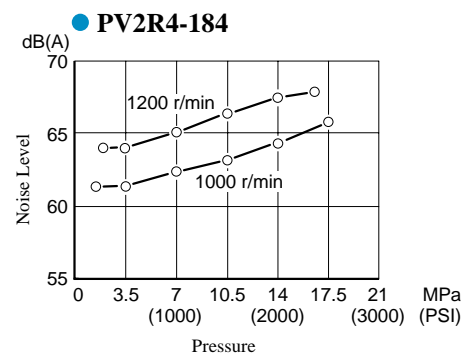
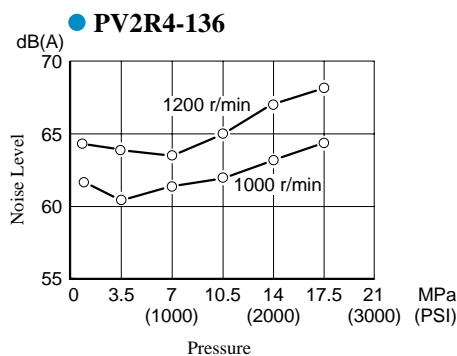
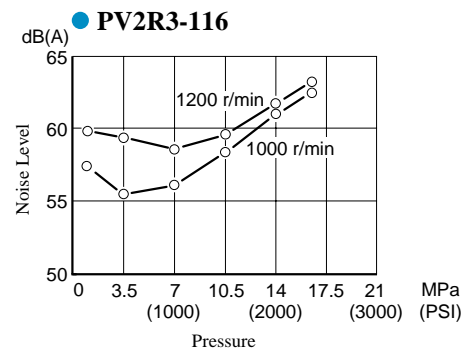
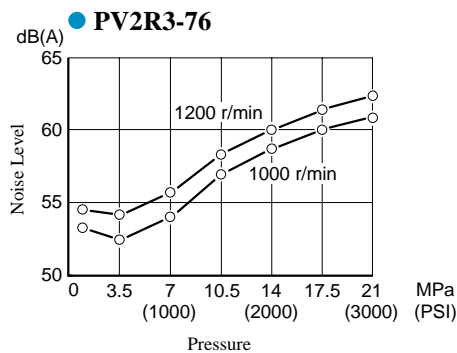
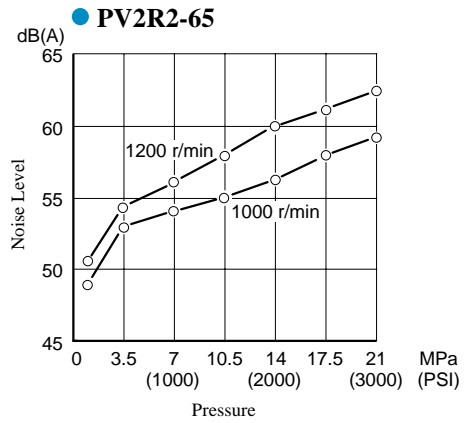
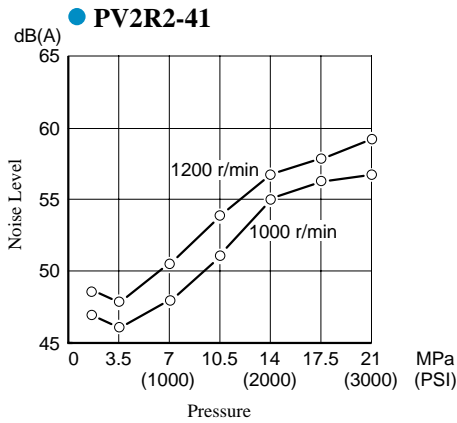
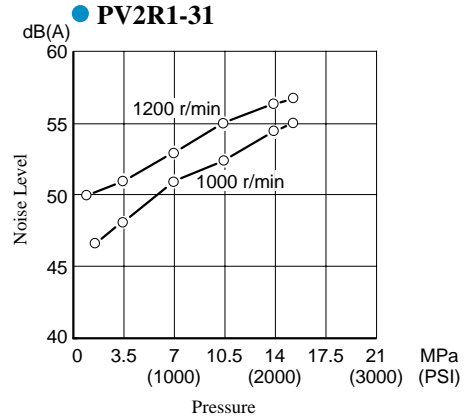
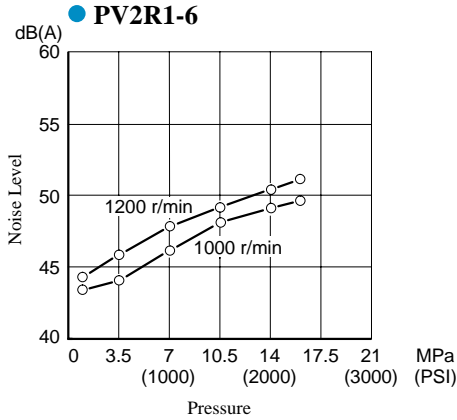

Viscosity 20 mm²/s (100 SSU) [ISO VG32 Oils, 50°C (122°F)]

● PV2R1-6

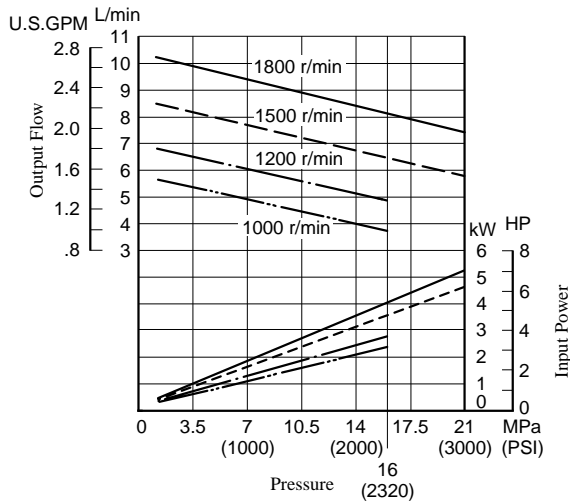

● PV2R1-8

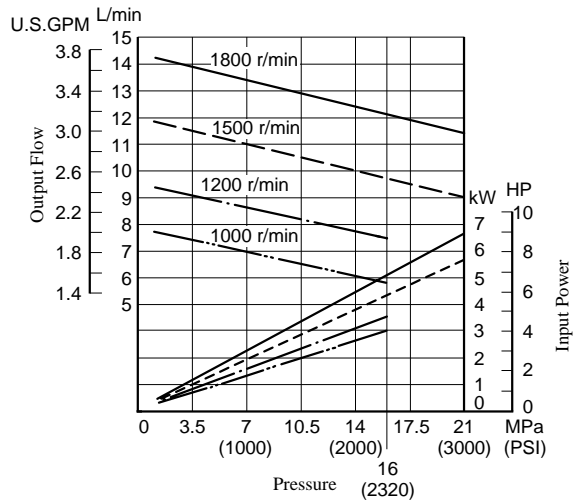

● PV2R1-10

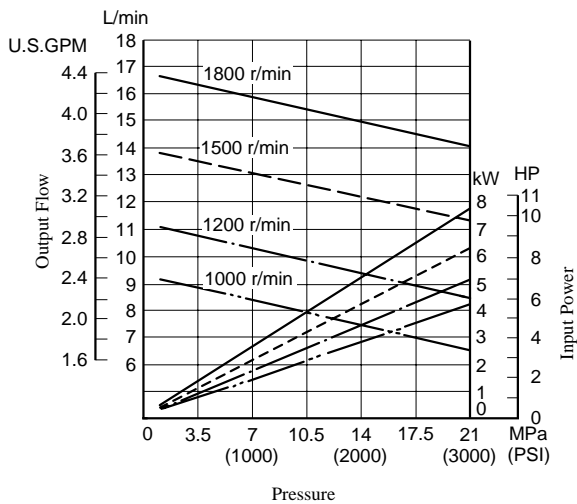

● PV2R1-12

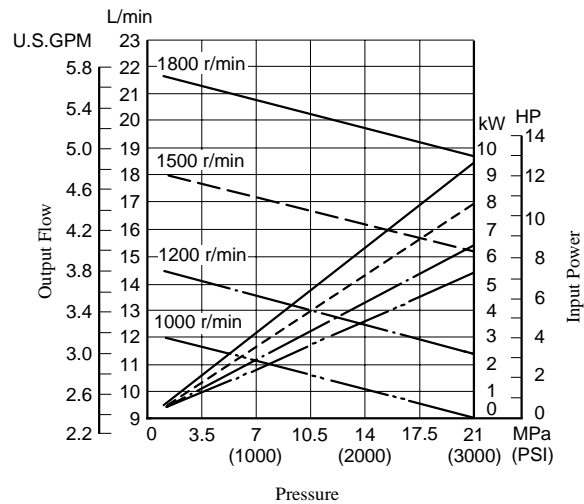

Viscosity 20 mm²/s (100 SSU) [ISO VG32 Oils, 50°C (122°F)]

● PV2R1-14

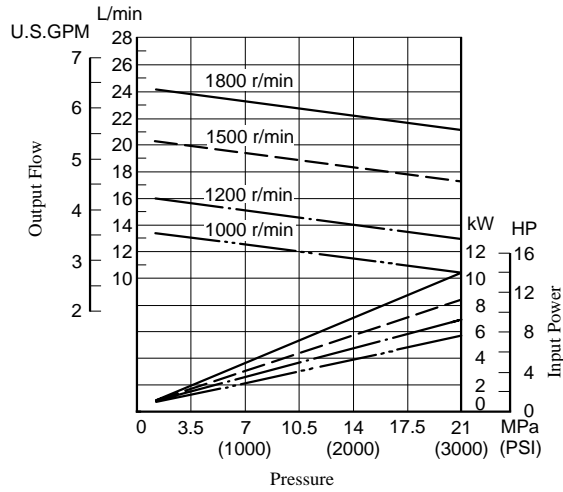

● PV2R1-17

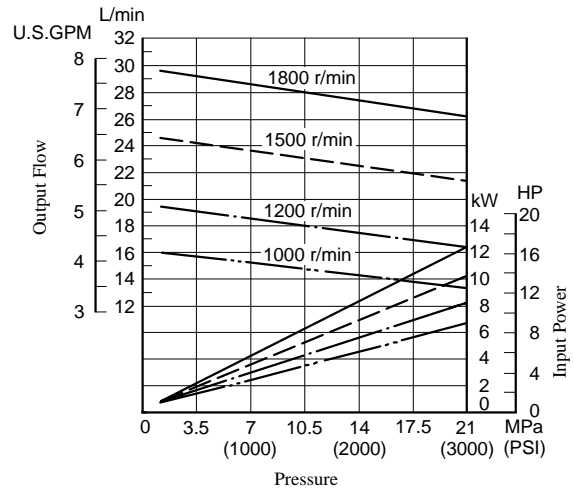

● PV2R1-19

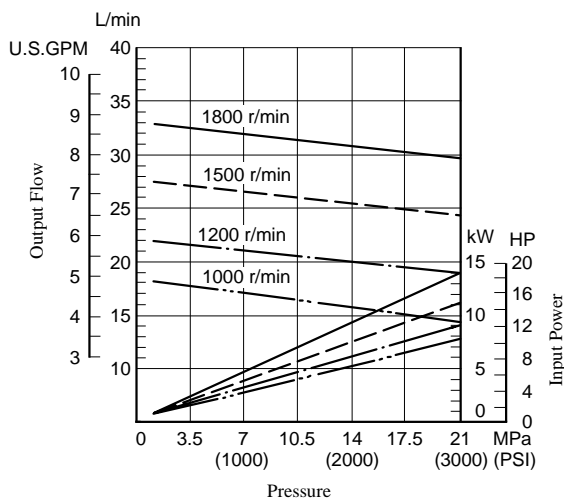

● PV2R1-23

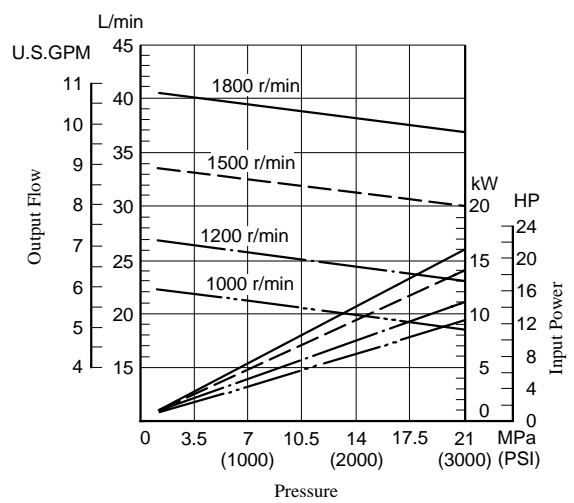

Viscosity 20 mm²/s (100 SSU) [ISO VG32 Oils, 50°C (122°F)]

● PV2R1-25

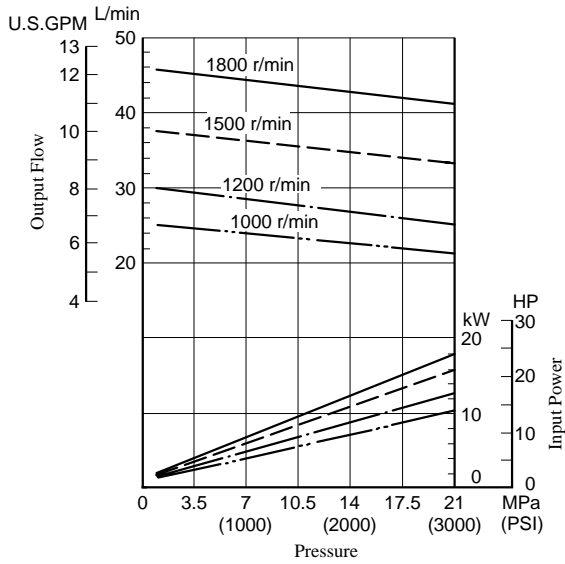

● PV2R1-31

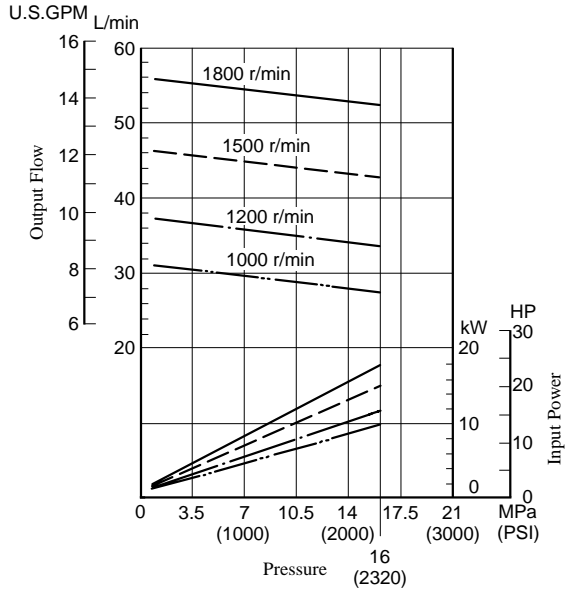

● PV2R2-41

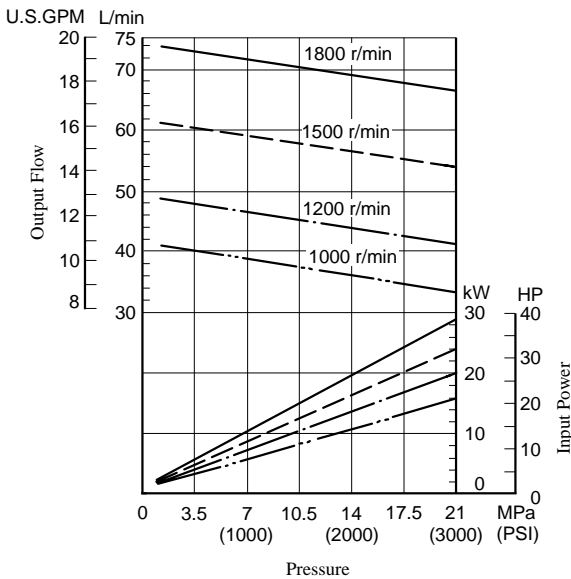

● PV2R2-47

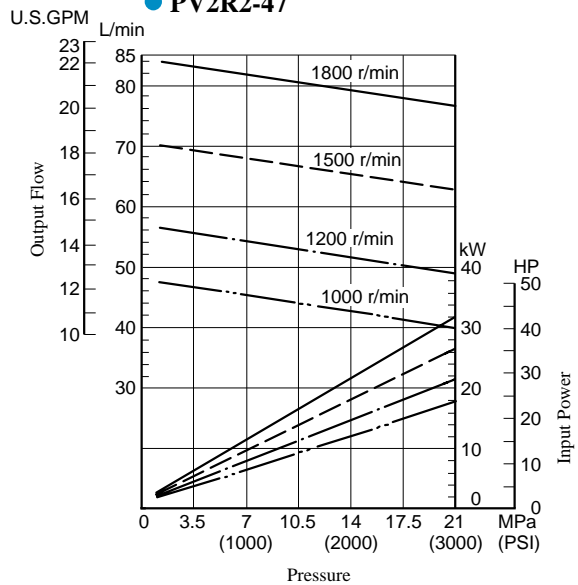

Viscosity 20 mm²/s (100 SSU) [ISO VG32 Oils, 50°C (122°F)]

● **PV2R2-53**

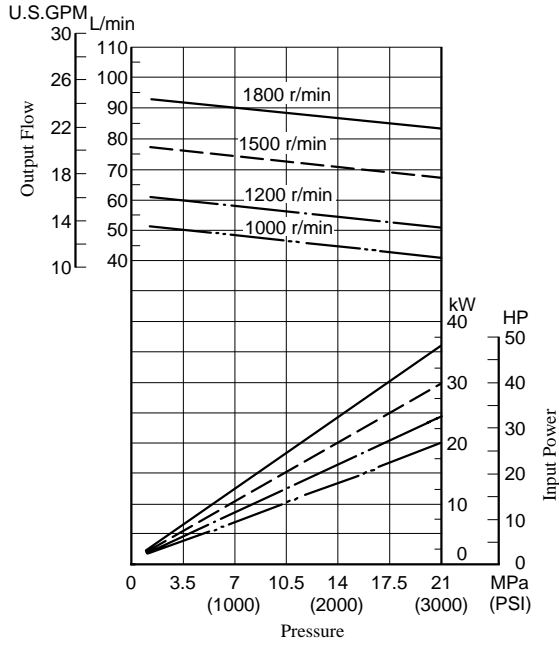

● **PV2R2-59**

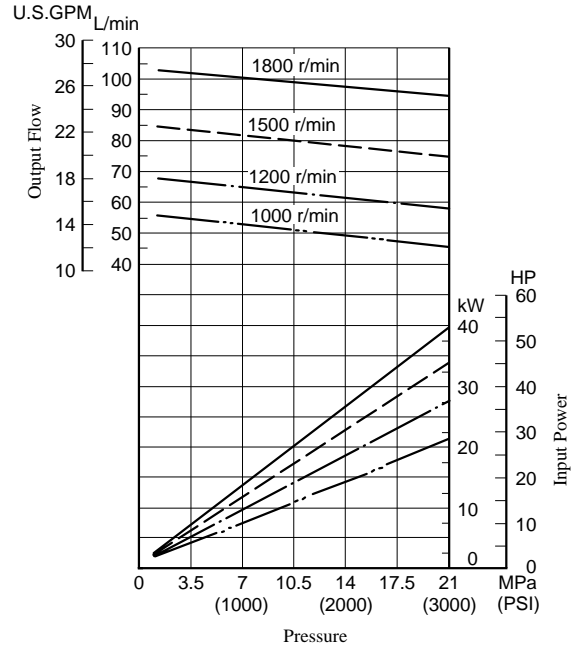

● **PV2R2-65**

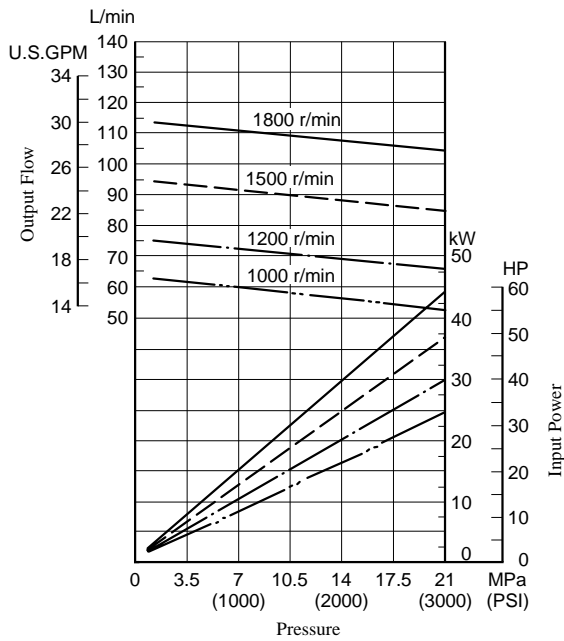

Viscosity 20 mm²/s (100 SSU) [ISO VG32 Oils, 50°C (122°F)]

● PV2R3-76

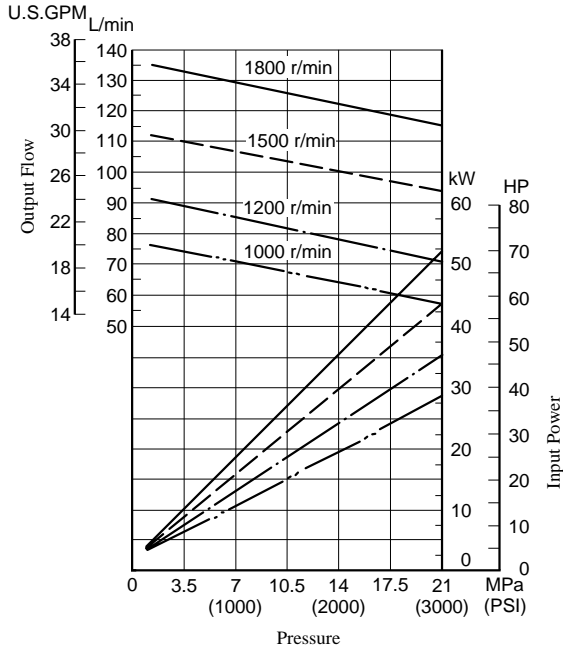

● PV2R3-94

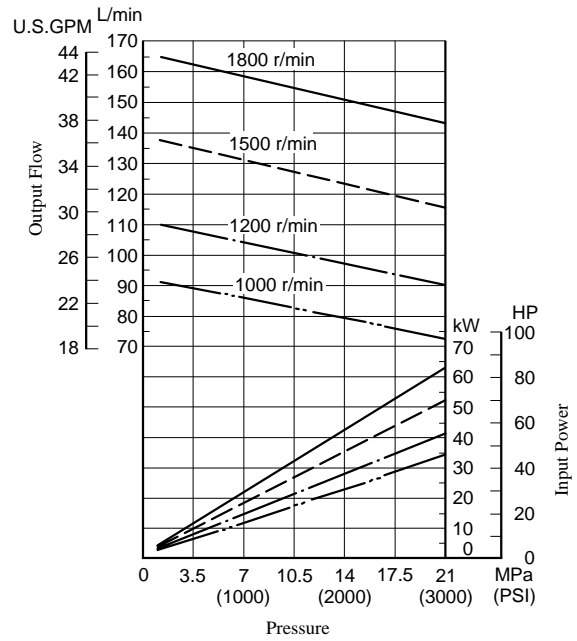

● PV2R3-116

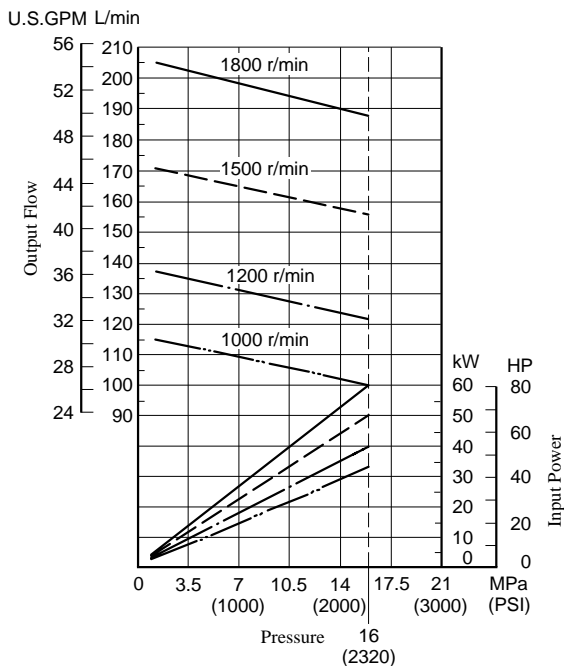

● PV2R4-136

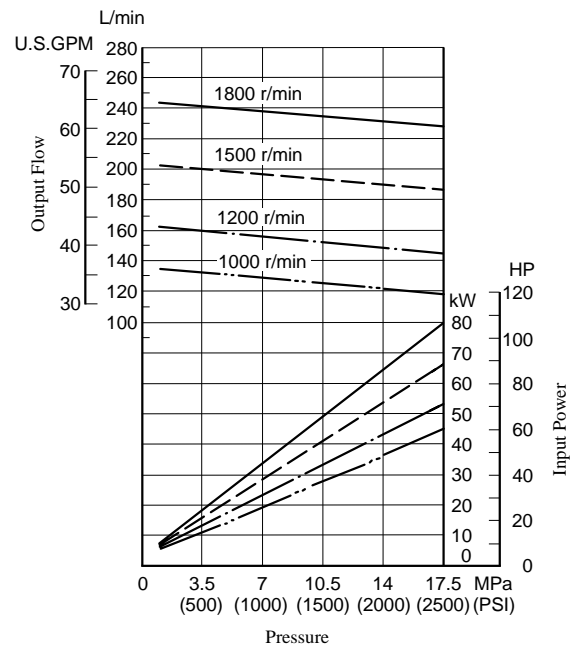

Viscosity 20 mm²/s (100 SSU) [ISO VG32 Oils, 50°C (122°F)]

● **PV2R4-153**

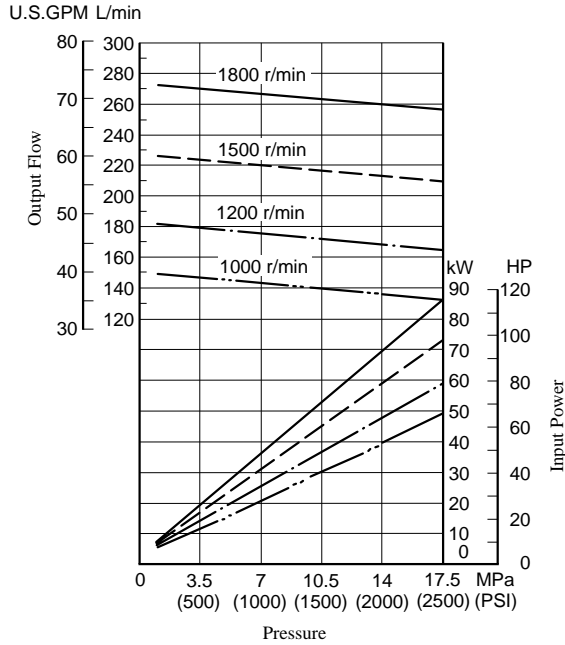

● **PV2R4-184**

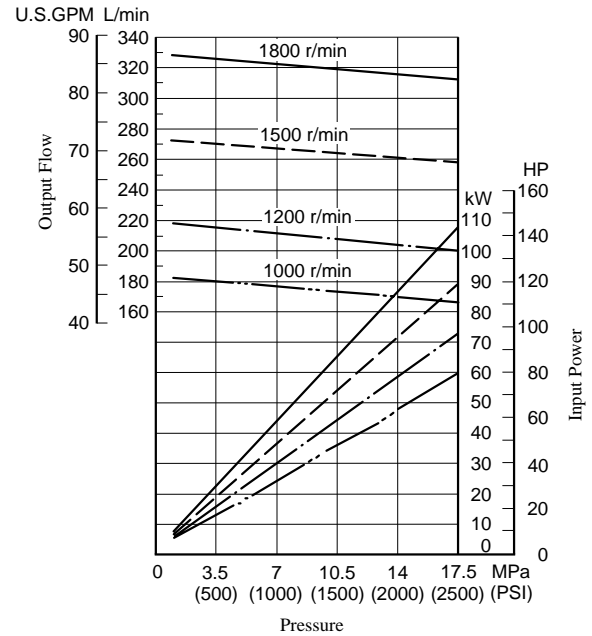

● **PV2R4-200**

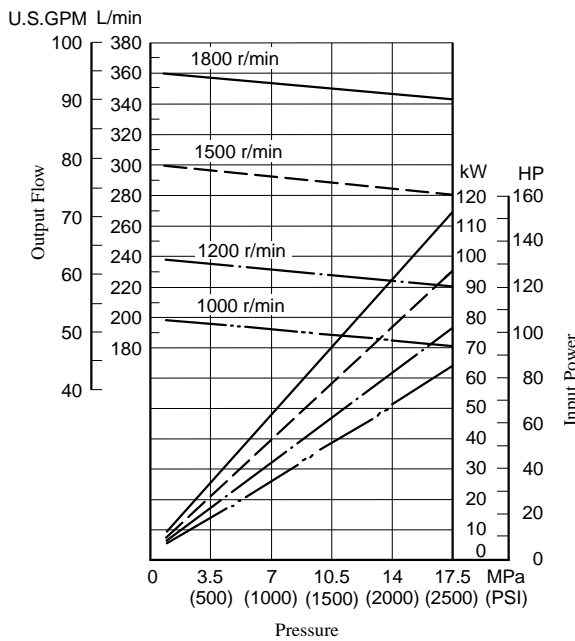

● **PV2R4-237**

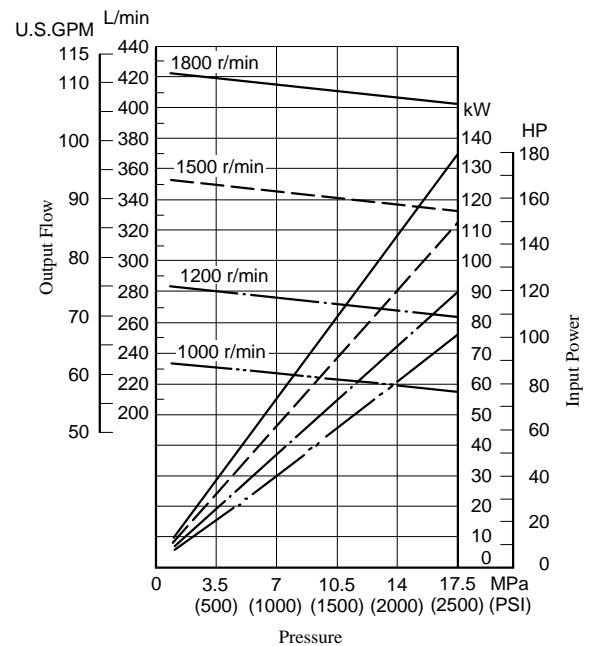

PV2R1-**-RAA-40/4090
PV2R2-**-RAA-40/4090
PV2R3-**-RAA-30/3090
PV2R4-**-RAA-30/3090

⚠ CAUTION

When making replacement of seals, bearings or cartridge kits, please do it carefully after reading through the relevant instructions in the Operator's Manual.

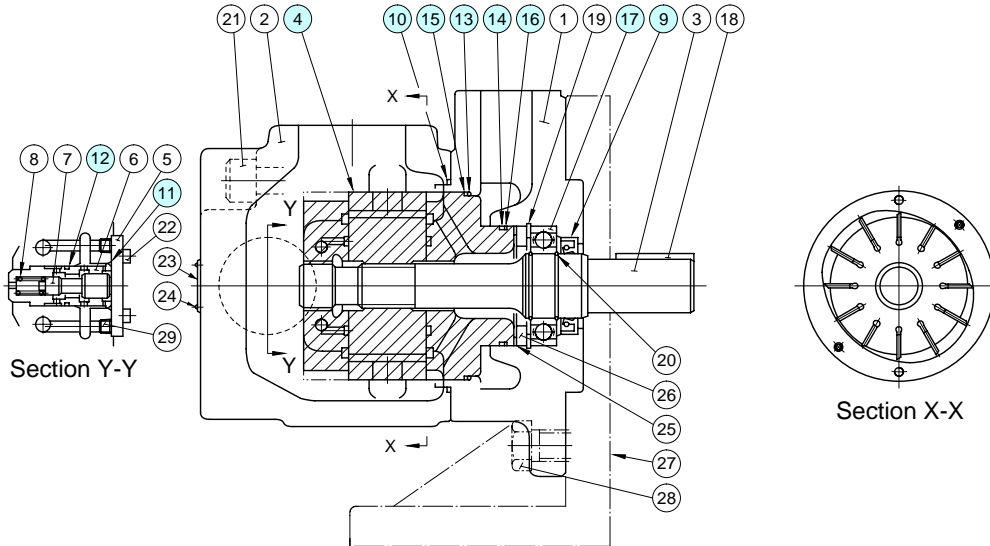

● Cartridge Kits

Model Numbers	④ Cartridge Kit Numbers	Model Numbers	④ Cartridge Kit Numbers
PV2R1-6-*-RAA-40*	CPV2R1-6-R-40	PV2R2-41-*-RAA-40*	CPV2R2-41-R-40
PV2R1-8-*-RAA-40*	CPV2R1-8-R-40	PV2R2-47-*-RAA-40*	CPV2R2-47-R-40
PV2R1-10-*-RAA-40*	CPV2R1-10-R-40	PV2R2-53-*-RAA-40*	CPV2R2-53-R-40
PV2R1-12-*-RAA-40*	CPV2R1-12-R-40	PV2R2-59-*-RAA-40*	CPV2R2-59-R-40
PV2R1-14-*-RAA-40*	CPV2R1-14-R-40	PV2R2-65-*-RAA-40*	CPV2R2-65-R-40
PV2R1-17-*-RAA-40*	CPV2R1-17-R-40	PV2R3-76-*-RAA-30*	CPV2R3-76-R-30
PV2R1-19-*-RAA-40*	CPV2R1-19-R-40	PV2R3-94-*-RAA-30*	CPV2R3-94-R-30
PV2R1-23-*-RAA-40*	CPV2R1-23-R-40	PV2R3-116-*-RAA-30*	CPV2R3-116-R-30
PV2R1-25-*-RAA-40*	CPV2R1-25-R-40	PV2R4-136-*-RAA-30*	CPV2R4-136-R-30
PV2R1-31-*-RAA-40*	CPV2R1-31-R-40	PV2R4-153-*-RAA-30*	CPV2R4-153-R-30
		PV2R4-184-*-RAA-30*	CPV2R4-184-R-30
		PV2R4-200-*-RAA-30*	CPV2R4-200-R-30
		PV2R4-237-*-RAA-30*	CPV2R4-237-R-30

● Seals & Bearings

Item	Name of Parts	Part Numbers				Qty.
		PV2R1	PV2R2	PV2R3	PV2R4	
9*	Oil Seal	ISD 26 42 8	ISD 30 42 8	ISD 35 55 11	ISD 45 68 12	1
10*	O-Ring	SO-NB-G80	SO-NB-G105	SO-NB-G135	SO-NB-G145	1
11*	O-Ring	---	---	---	SO-NB-P28	1
12*	O-Ring	---	---	---	SO-NB-P22A	1
13*	O-Ring	SO-NB-G60	SO-NB-G85	SO-NB-G115	SO-NA-G130	1
14*	O-Ring	SO-NB-G30	SO-NB-P46	SO-NB-A231	SO-NA-G80	1
15*	Back Up Ring	---	---	---	SO-BE-G130	1
16*	Back Up Ring	---	---	---	SO-BB-G80	1
17	Bearing	6004	6205	6207	6209	1

Note: 1) Item Nos. ⑬ and ⑭ (o-rings) and ⑮ and ⑯ (back up rings) are included in cartridge kit.

2) For pumps for phosphate ester type hydraulic fluids different part Nos. are used. Please contact us.

★ When ordering seals, please specify the kit number from the table right.

Pump Model Numbers	Seal Kit Numbers
PV2R1-**-RAA-40/4090	KS-PV2R1-40
PV2R2-**-RAA-40/4090	KS-PV2R2-40
PV2R3-**-RAA-30/3090	KS-PV2R3-30
PV2R4-**-RAA-30/3090	KS-PV2R4-30

Model Number Designation

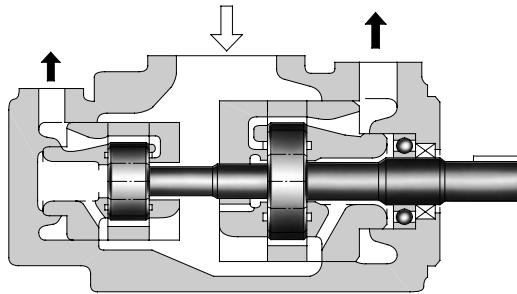
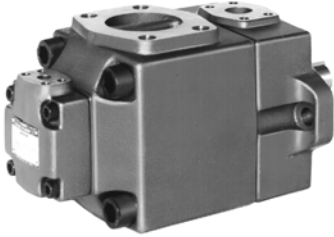

Graphic Symbols

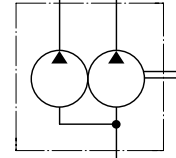

Model Number Designation

F-	PV2R13	-6	-76	-L	-R	A	A	A	-40	*
Special Seals	Series Number	Small Volume Pump Nominal Displacement cm ³ /rev	Large Volume Pump Nominal Displacement cm ³ /rev	Mounting	Direction of Rotation	Small Volume Pump Discharge Port Position	Large Volume Pump Discharge Port Position	Suction Port Position	Design Number	Design Standards
F: Special seals for phosphate ester type fluids (Omit if not required)	PV2R12	6, 8 10, 12 14, 17 19, 23 25, 31	26, 33 41, 47 53, 59 65	L: Foot Mtg.	R: ^{★1} Clockwise (Normal)	(Viewed from Shaft End)		A: Upwards (Normal)	40	Refer to ^{★2}
	PV2R13	6, 8 10, 12 14, 17 19, 23 25, 31	76, 94 116			A: Upwards (Normal)	40			
	PV2R23	41, 47 53, 59 65	52, 60 66, 76 94, 116			A: Left 45° Upwards (Normal)	40			
	PV2R33	76, 94 116	76, 94 116	F: Flange Mtg.		A: Upwards (Normal)	30			
	PV2R14	6, 8 10, 12 14, 17 19, 23	136, 153 184, 200 237			A: Upwards (Normal)	30			
	PV2R24	26, 33 41, 47				A: Upwards (Normal)	30			
	PV2R34	52, 60 66, 76 94, 116				E: Left 45° Upwards (Normal)	30			

★1. Available to supply pump with anti-clockwise rotation. Consult Yuken for details.

★2. Design Standards: None Japanese Standard "JIS" and European Design Standard 90 N. American Design Standard

Specifications

■ Specifications

● Maximum Operating Pressure

Nominal Displacement cm ³ /rev	Max. Operating Pressure MPa (PSI)					
	Petroleum Base Oils		Water Containing Fluids			Synthetic Fluids
	Anti-Wear Type	R & O Type	Anti-Wear ^{★1} Type Water Glycols	Water Glycols	Water in Oil Emulsions	Phosphate Esters
6	21 ^{★2} (3050)	16 (2320)	16 (2320)	7 (1020)	7 (1020)	16 (2320)
8						
10						
12						
14						
17						
19						
23 ^{★3}						
25						
31						
26	21 (3050)	14 (2030)	16 (2320)	7 (1020)	7 (1020)	14 (2030)
33						
41						
47						
53						
59						
65						
52	21 (3050)	14 (2030)	16 (2320)	7 (1020)	7 (1020)	14 (2030)
60						
66						
76						
94						
116						
136	17.5 (2540)	14 (2030)	16 (2320)	7 (1020)	7 (1020)	14 (2030)
153						
184						
200						
237						

Note: 1) For the relation between model (series) No. and nominal displacement, see the table below.

	Nominal Displacement, Large Volume Pump			
	26, 33, 41, 47, 53, 59, 65	52, 60, 66	76, 94, 116	136, 153, 184, 200, 237
Nominal Displacement, Small Volume Pump	6	PV2R12	PV2R13	PV2R14
	8			
	10			
	12			
	14			
	17			
	19			
	23			
	25			
	31			
26	PV2R23	PV2R24	PV2R24	
33				
41				
47				
53				
59	PV2R34	PV2R33	PV2R34	
65				
76				
94				
116				

2) As for PV2R12 and PV2R33 series, the sum of the input powers to small volume pump and large volume pump is limited against shaft speed as follows.

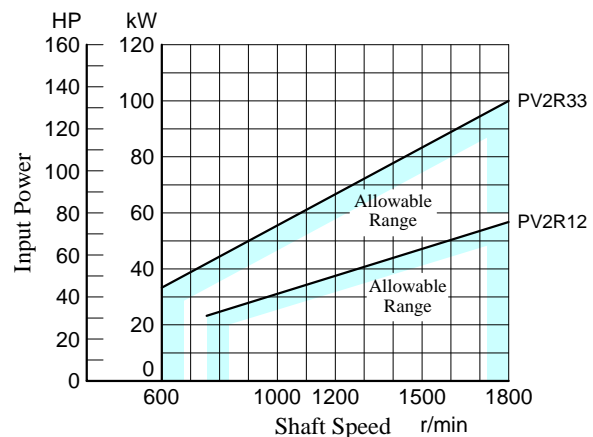

- ★ 1. For the brands of anti-wear water-glycols, see the item of "Hydraulic Fluids" on page 3.
- ★ 2. For pressures above 16 MPa (2320 PSI), raise the speed over 1450 r/min.
- ★ 3. If nominal displacement "23", of the PV2R14 series is selected, the maximum operating pressure is limited to 16 MPa (2320 PSI).

Specifications

● Shaft Speed Range

Model Numbers	Shaft Speed Range r/min			
	Petroleum Base Oils		Water Containing Fluids Phosphate Esters	
	Max.	Min.	Max.	Min.
PV2R12	1800	750 ^{★3}	1200	750 ^{★3}
PV2R13	1800 ^{★2}	750 ^{★3}	1200	750 ^{★3}
PV2R23	1800 ^{★2}	600 ^{★3}	1200	600 ^{★3}
PV2R33	1800 ^{★2} (1500) ^{★1}	600	1200	600
PV2R14	1800 ^{★2}	750 ^{★3}	1200	750 ^{★3}
PV2R24	1800 ^{★2}	600 ^{★3}	1200	600 ^{★3}
PV2R34	1800 ^{★2}	600	1200	600

- ★ 1. For PV2R33-116-116, the maximum speed is limited to 1500 r/min.
- ★ 2. As for the models (nominal displacements) listed below, the minimum suction pressure are limited in relation to the shaft speed.
[For other models, the minimum suction pressure is -20 kPa (5.9 in. Hg vacuum) irrespective of speed.

Model Numbers	Min. Suction Pres. kPa (in. Hg Vacuum)	
	Less than 1700 r/min	1700 - 1800 r/min
PV2R13-*-116 PV2R23-*-116	-20 (5.9)	0 (0)
PV2R23-*-76 PV2R23-*-94 PV2R33-*-76	-20 (5.9)	-7 (1.97)
PV2R33-94-* PV2R33-116-* PV2R33-*-94 PV2R33-*-116	-20 (5.9)	0 (0)
PV2R14-*-237 PV2R24-*-237 PV2R34-*-237	-20 (5.9)	-13 (3.94)
PV2R34-116-*	-20 (5.9)	0 (0)

- ★ 3. For starting at low speed, the maximum viscosity is limited.
For details, see the item of "Hydraulic Fluids" on page 3.

● Output Flow & Input Power

The pump characteristics are the same as those for PV2R series single pumps. See the pages concerned.

Model Numbers	Output Flow & Input Power	
	Small Volume Pump	Large Volume Pump
PV2R12	Same as single pump "PV2R1", refer to pages 11 - 13.	Same as single pump "PV2R2", refer to pages 13&14. However, as for displacement of "26" and "33", refer to page 29.
PV2R13	Same as single pump "PV2R1", refer to pages 11 - 13.	Same as single pump "PV2R3", refer to page 15.
PV2R23	Same as single pump "PV2R2", refer to pages 13&14.	Same as single pump "PV2R3", refer to page 15. However, as for displacement of "52", "60" and "66", refer to pages 29&30.
PV2R33	Same as single pump "PV2R3", refer to page 15.	Same as single pump "PV2R3", refer to page 15.
PV2R14	Same as single pump "PV2R1", refer to pages 11 - 13.	Same as single pump "PV2R4", refer to pages 15&16.
PV2R24	Same as single pump "PV2R2", refer to pages 13&14. However, as for displacement of "26" and "33", refer to page 29.	
PV2R34	Same as single pump "PV2R3", refer to page 15. However, as for displacement of "52", "60" and "66", refer to pages 29&30.	

● Mass

Mounting	Model Numbers	Approx. Mass kg (lbs.)						
		PV2R12	PV2R13	PV2R23	PV2R33	PV2R14	PV2R24	PV2R34
Flange Mtg.		25 (55.1)	45.6 (101)	51 (113)	84 (185)	75 (165)	78 (172)	98 (216)
Foot Mtg.		29.3 (64.6)	55.6 (123)	61 (135)	94 (207)	100 (221)	103 (227)	123 (271)

■ Pipe Flange Kits

Pipe flange kits are available. When ordering, specify the kit the number from the table below.

Pump Model Numbers	Name of Port	Pipe Flange Kit Numbers						
		Threaded Connection			Socket Welding*		Butt Welding	
		Japanese Standard "JIS"	European Design Standard	N. American Design Standard	Japanese Standard "JIS" European Design Standard	N. American Design Standard	Japanese Standard "JIS" European Design Standard	N. American Design Standard
PV2R12	Suction	F5-16-A-10	F5-16-A-1080	F5-16-A-1090	F5-16-B-10	F5-16-B-1090	F5-16-C-10	F5-16-C-1090
	Large Discharge	F5-06-A-10	F5-06-A-1080	F5-06-A-1090	F5-06-B-10	F5-06-B-1090	F5-06-C-10	F5-06-C-1090
	Small Discharge	F5-04-A-10	F5-04-A-1080	F5-04-A-1090	F5-04-B-10	F5-04-B-1090	F5-04-C-10	F5-04-C-1090
PV2R13	Suction	F5-24-A-10	—	—	F5-24-B-10	F5-24-B-1090	F5-24-C-10	F5-24-C-1090
	Large Discharge	F5-10-A-10	F5-10-A-1080	F5-10-A-1090	F5-10-B-10	F5-10-B-1090	F5-10-C-10	F5-10-C-1090
	Small Discharge	F5-04-A-10	F5-04-A-1080	F5-04-A-1090	F5-04-B-10	F5-04-B-1090	F5-04-C-10	F5-04-C-1090
PV2R23	Suction	F5-24-A-10	—	—	F5-24-B-10	F5-24-B-1090	F5-24-C-10	F5-24-C-1090
	Large Discharge	F5-10-A-10	F5-10-A-1080	F5-10-A-1090	F5-10-B-10	F5-10-B-1090	F5-10-C-10	F5-10-C-1090
	Small Discharge	F5-06-A-10	F5-06-A-1080	F5-06-A-1090	F5-06-B-10	F5-06-B-1090	F5-06-C-10	F5-06-C-1090
PV2R33	Suction	F5-28-A-10	—	—	F5-28-B-10	F5-28-B-1090	F5-28-C-10	F5-28-C-1090
	Large Discharge	F5-10-A-10	F5-10-A-1080	F5-10-A-1090	F5-10-B-10	F5-10-B-1090	F5-10-C-10	F5-10-C-1090
	Small Discharge	F5-10-A-10	F5-10-A-1080	F5-10-A-1090	F5-10-B-10	F5-10-B-1090	F5-10-C-10	F5-10-C-1090
PV2R14	Suction	F5-28-A-10	—	—	F5-28-B-10	F5-28-B-1090	F5-28-C-10	F5-28-C-1090
	Large Discharge	F5-12-A-10	F5-12-A-1080	F5-12-A-1090	F5-12-B-10	F5-12-B-1090	F5-12-C-10	F5-12-C-1090
	Small Discharge	F5-04-A-10	F5-04-A-1080	F5-04-A-1090	F5-04-B-10	F5-04-B-1090	F5-04-C-10	F5-04-C-1090
PV2R24	Suction	F5-28-A-10	—	—	F5-28-B-10	F5-28-B-1090	F5-28-C-10	F5-28-C-1090
	Large Discharge	F5-12-A-10	F5-12-A-1080	F5-12-A-1090	F5-12-B-10	F5-12-B-1090	F5-12-C-10	F5-12-C-1090
	Small Discharge	F5-06-A-10	F5-06-A-1080	F5-06-A-1090	F5-06-B-10	F5-06-B-1090	F5-06-C-10	F5-06-C-1090
PV2R34	Suction	F5-32-A-10	—	—	F5-32-B-10	F5-32-B-1090	F5-32-C-10	F5-32-C-1090
	Large Discharge	F5-12-A-10	F5-12-A-1080	F5-12-A-1090	F5-12-B-10	F5-12-B-1090	F5-12-C-10	F5-12-C-1090
	Small Discharge	F5-10-A-10	F5-10-A-1080	F5-10-A-1090	F5-10-B-10	F5-10-B-1090	F5-10-C-10	F5-10-C-1090

★ In case of using socket welding flanges, there is a case where the operating pressure should be set lower than the normal because of strength of the flanges. Therefore, please pay cautious attention to the operating pressure when the socket welding flanges are used.

Notes: Special seals (Viton seals) are required when phosphate ester type fluids are used. (Prefix "F-" to the pipe flange kit number when ordering.)

● Details of the pipe flange kits are given in the Catalogue No. Pub. EC-3001.

Flange Mtg.: PV2R12-**-F-REAA-40/4090

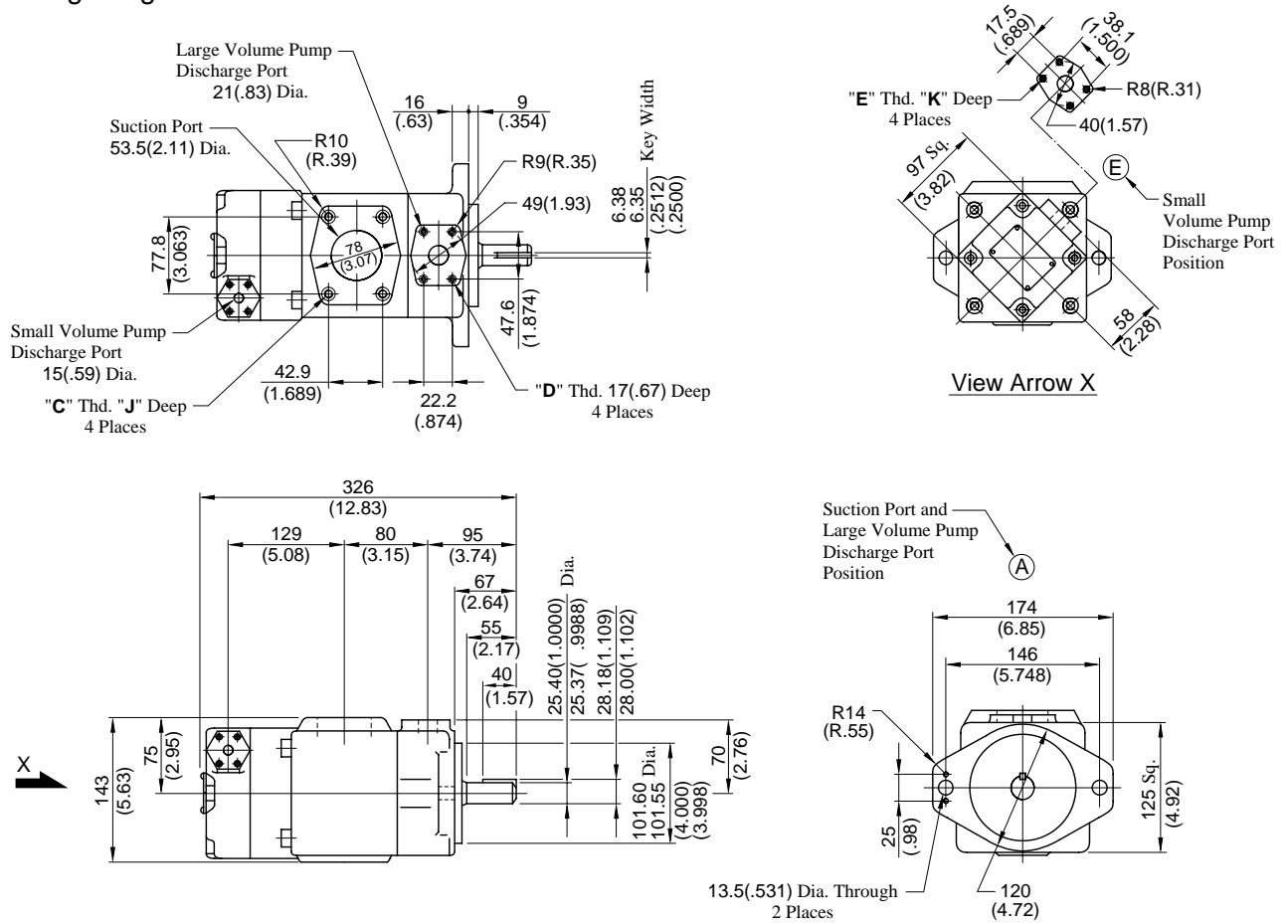

Model Numbers	"C" Thd.	"D" Thd.	"E" Thd.	Dimensions mm (Inches)	
				J	K
PV2R12-**-F-REAA-40	M12	M10	M8	19 (.75)	14 (.55)
PV2R12-**-F-REAA-4090	1/2-13 UNC	3/8-16 UNC	5/16-18 UNC	21 (.83)	16 (.63)

**DIMENSIONS IN
MILLIMETRES (INCHES)**

Foot Mtg.: PV2R12-**-L-REAA-40/4090

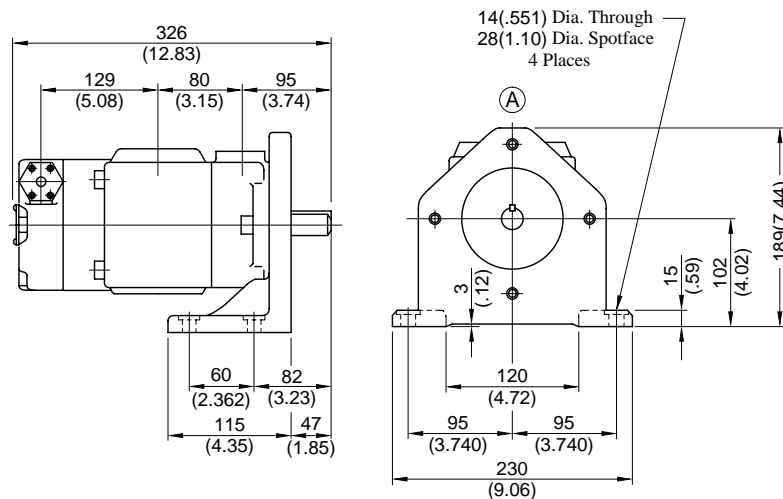

• For other dimensions, refer to "Flange Mtg.".

Flange Mtg.: PV2R13-**-F-RAAA-40/4090

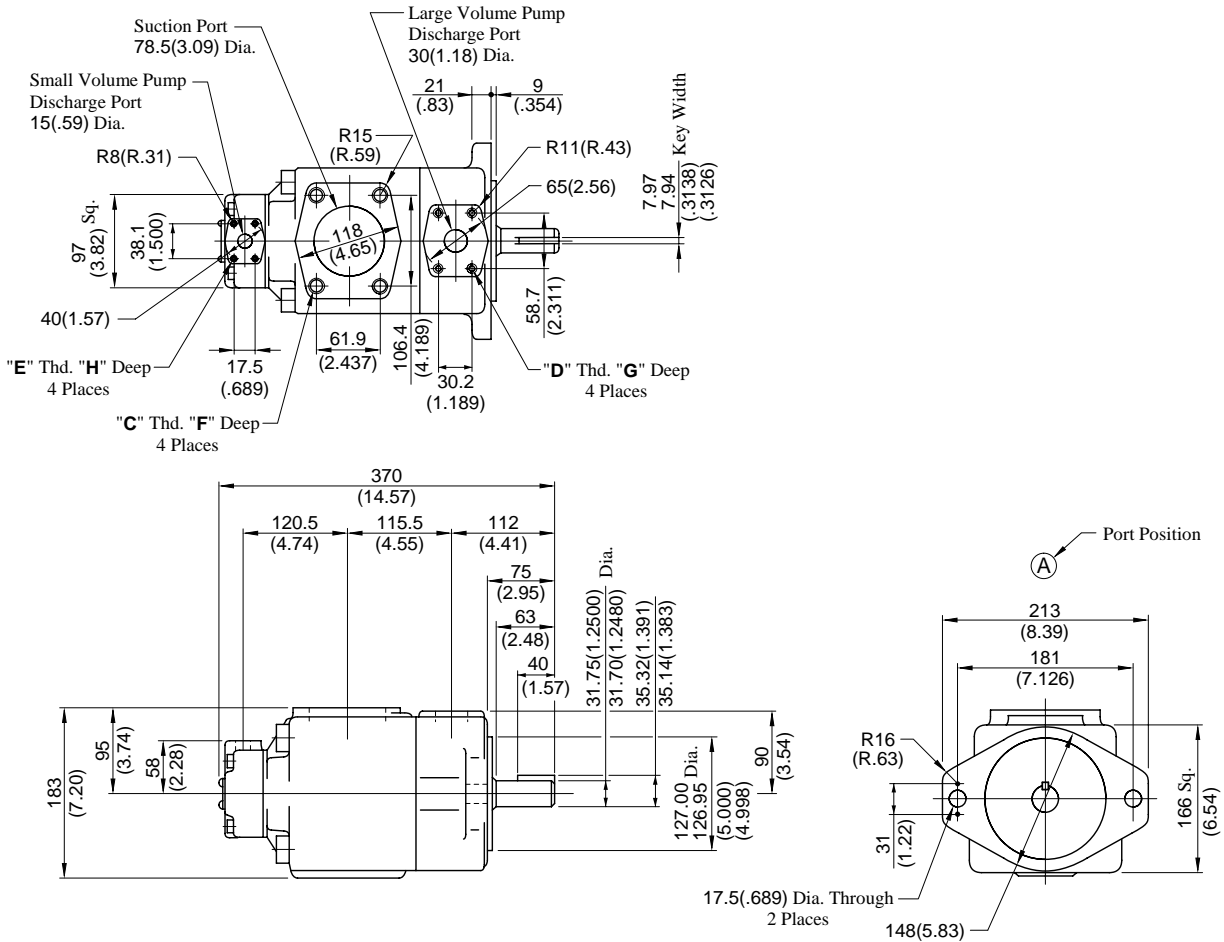

Model Numbers	"C" Thd.	"D" Thd.	"E" Thd.	Dimensions mm (Inches)		
				F	G	H
PV2R13-**-F-RAAA-40	M16	M10	M8	19 (.75)	19 (.75)	14 (.55)
PV2R13-**-F-RAAA-4090	5/8-11 UNC	7/16-14 UNC	5/16-18 UNC	21 (.83)	20 (.79)	16 (.63)

DIMENSIONS IN
MILLIMETRES (INCHES)

Foot Mtg.: PV2R13-**-L-RAAA-40/4090

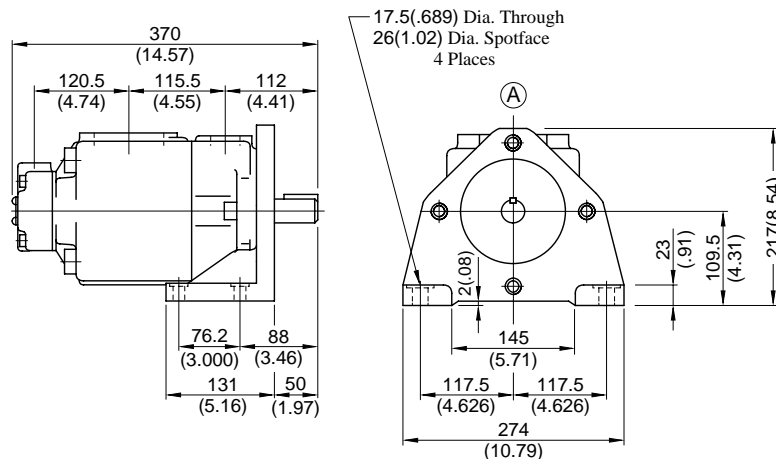

• For other dimensions, refer to "Flange Mtg.".

Flange Mtg.: PV2R23-**-F-REAA-40/4090

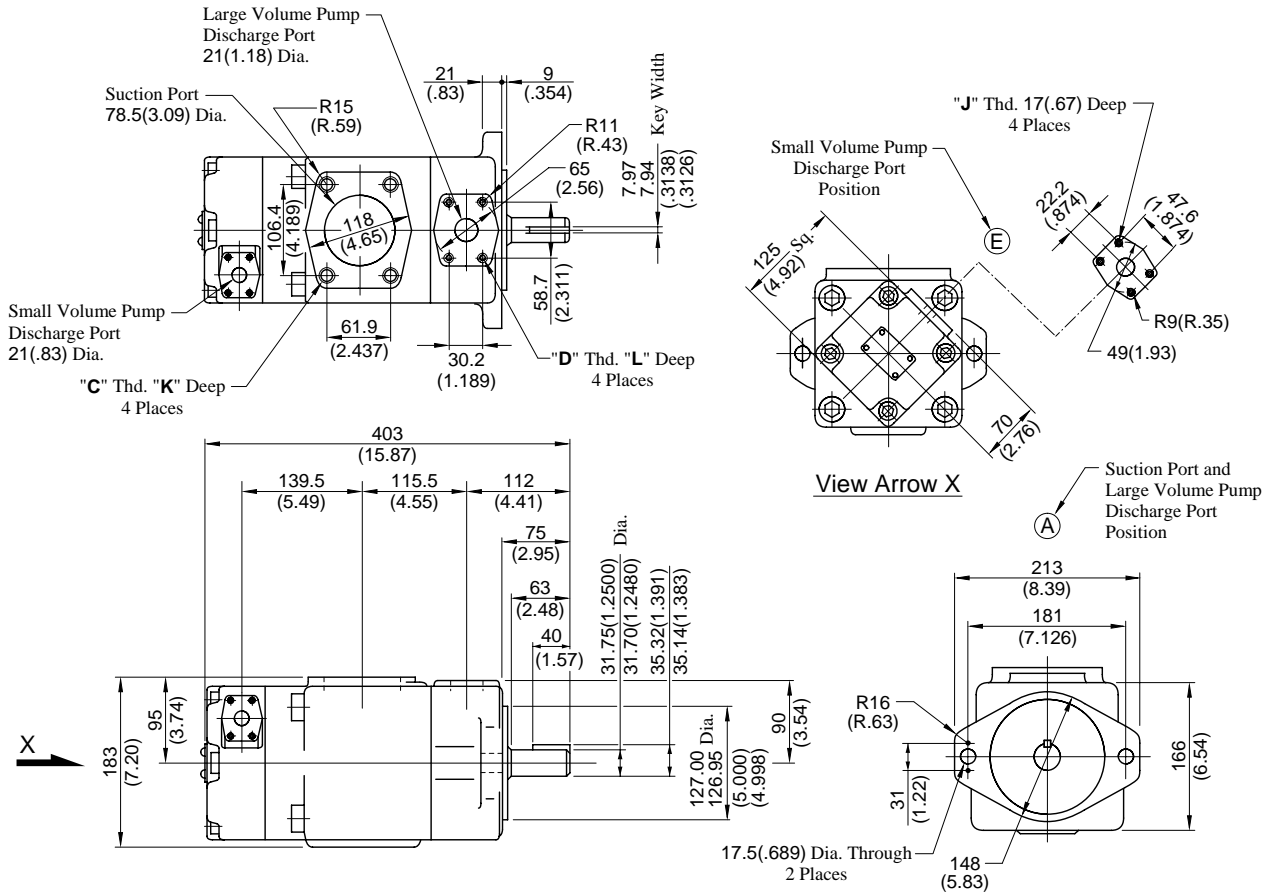

Model Numbers	"C" Thd.	"D" Thd.	"J" Thd.	Dimensions mm (Inches)	
				K	L
PV2R23-**-F-REAA-40	M16	M10	M10	19 (.75)	19 (.75)
PV2R23-**-F-REAA-4090	5/8-11 UNC	7/16-14 UNC	3/8-16 UNC	21 (.83)	20 (.79)

DIMENSIONS IN MILLIMETRES (INCHES)

Foot Mtg.: PV2R23-**-L-REAA-40/4090

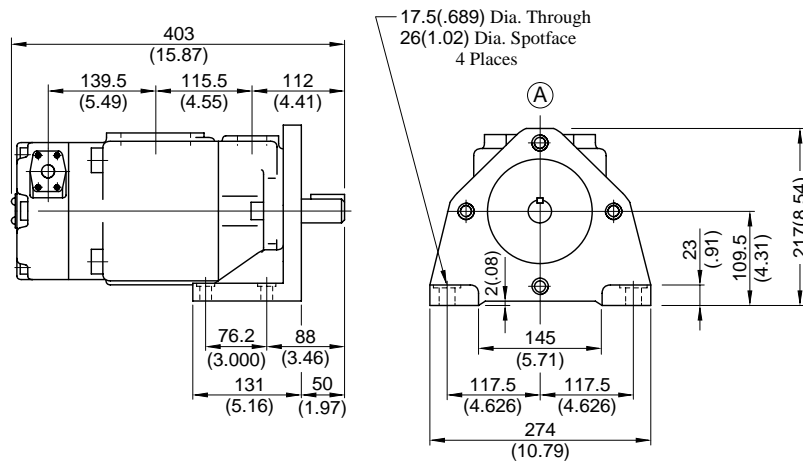

• For other dimensions, refer to "Flange Mtg.".

Flange Mtg.: PV2R33-*-F-RAAA-30/3090

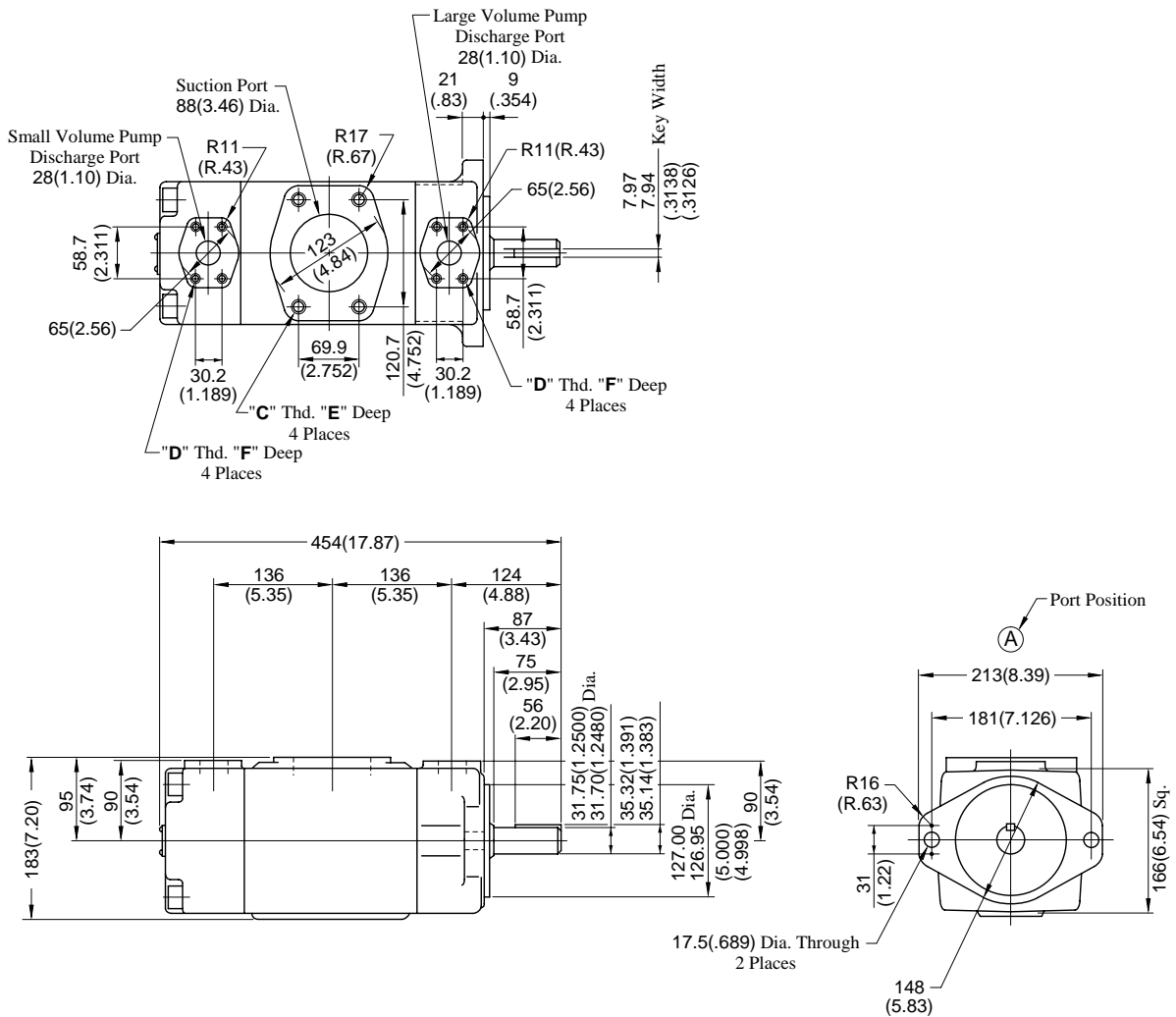

Model Numbers	"C" Thd.	"D" Thd.	Dimensions mm (Inches)	
			E	F
PV2R33-*-F-RAAA-30	M16	M10	19 (.75)	19 (.75)
PV2R33-*-F-RAAA-3090	5/8-11 UNC	7/16-14 UNC	21 (.83)	20 (.79)

**DIMENSIONS IN
MILLIMETRES (INCHES)**

Foot Mtg.: PV2R33-*-L-RAAA-30/3090

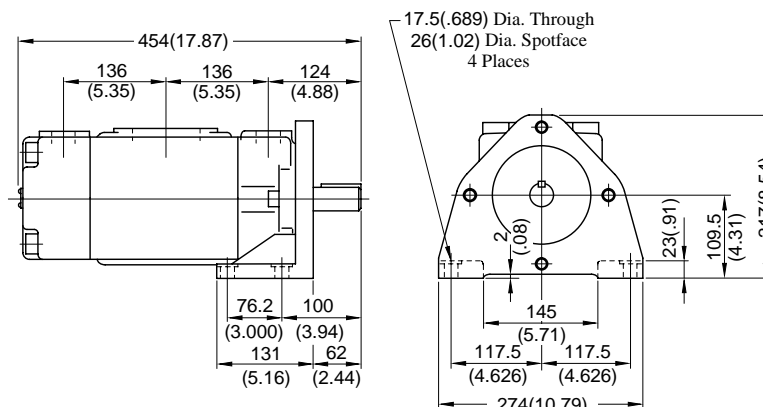

• For other dimensions, refer to "Flange Mtg.".

Flange Mtg.: PV2R14-**-F-RAAA-30/3090

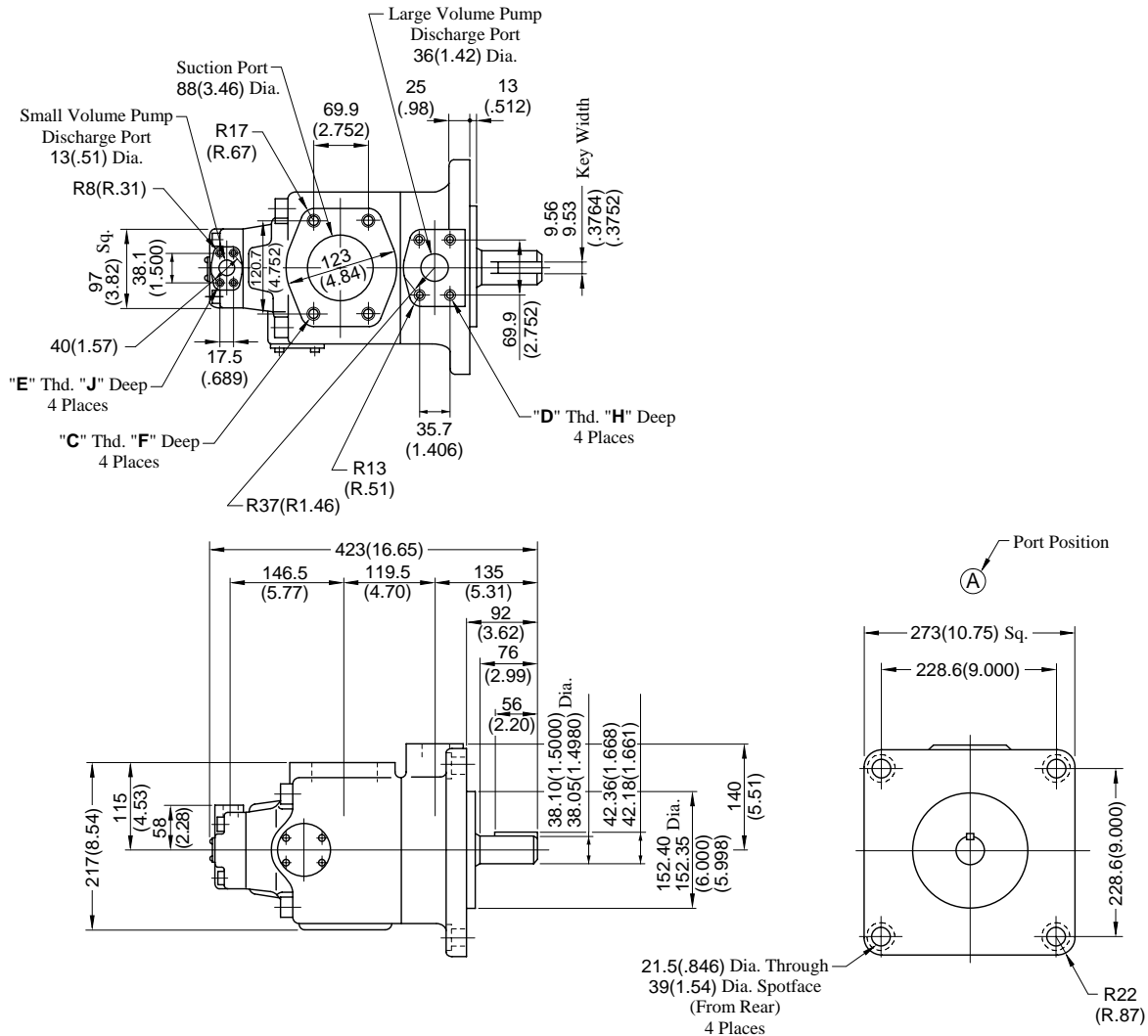

Model Numbers	"C" Thd.	"D" Thd.	"E" Thd.	Dimensions mm (Inches)		
				F	H	J
PV2R14-**-F-RAAA-30	M16	M12	M8	19 (.75)	19 (.75)	14 (.55)
PV2R14-**-F-RAAA-3090	5/8-11 UNC	1/2-13 UNC	5/16-18 UNC	21 (.83)	21 (.83)	16 (.63)

**DIMENSIONS IN
MILLIMETRES (INCHES)**

Foot Mtg.: PV2R14-**-L-RAAA-30/3090

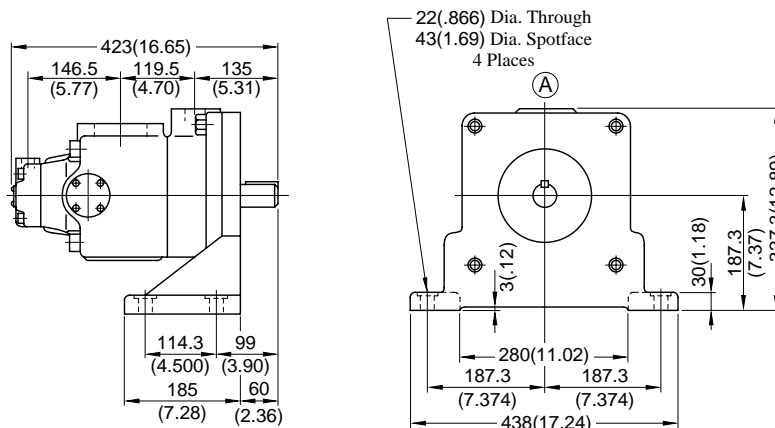

• For other dimensions, refer to "Flange Mtg.".

Flange Mtg.: PV2R24-**-F-RAAA-30/3090

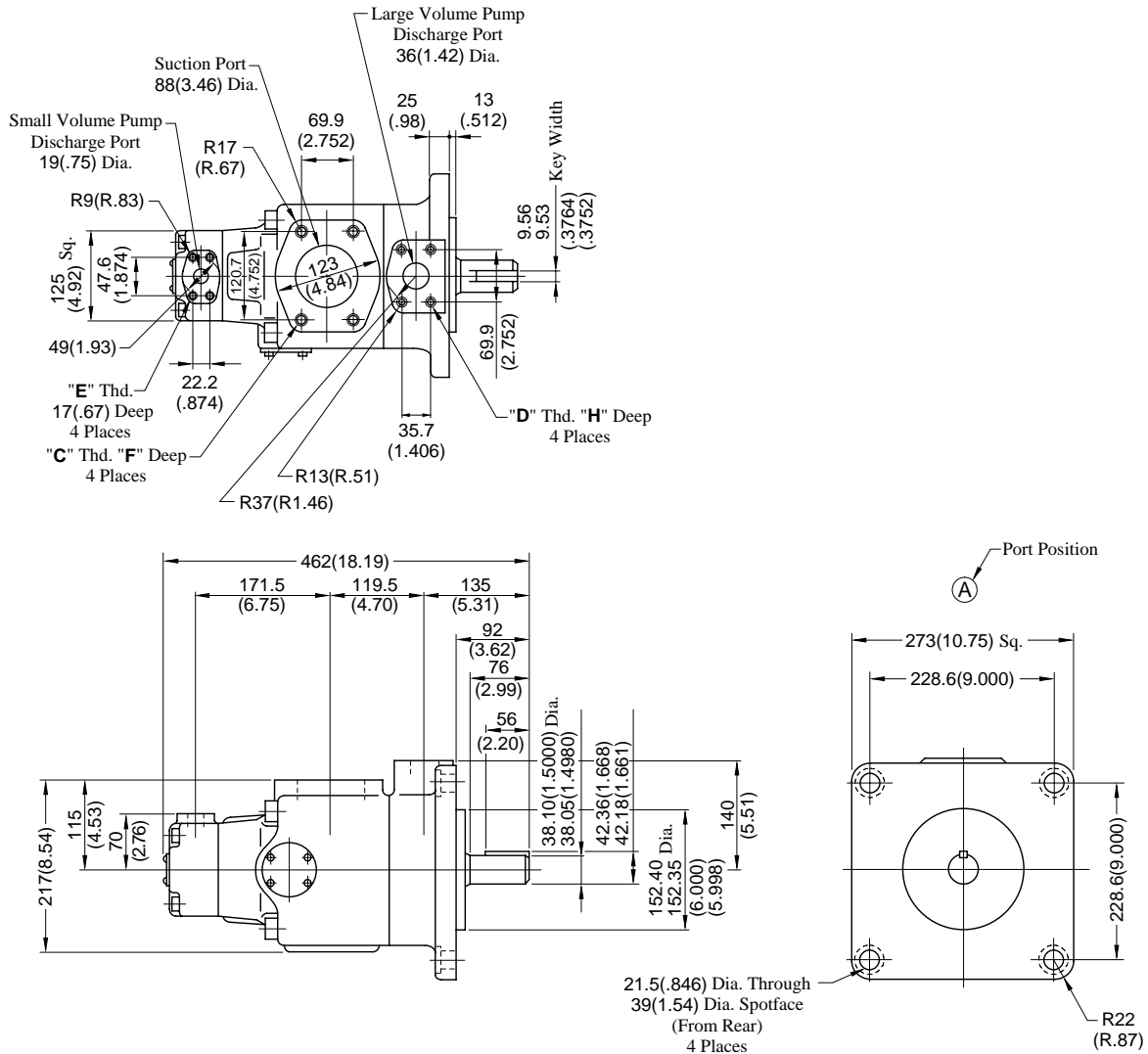

Model Numbers	"C" Thd.	"D" Thd.	"E" Thd.	Dimensions mm (Inches)	
				F	H
PV2R24**-F-RAAA-30	M16	M12	M10	19 (.75)	19 (.75)
PV2R24**-F-RAAA-3090	5/8-11 UNC	1/2-13 UNC	3/8-16 UNC	21 (.83)	21 (.83)

**DIMENSIONS IN
MILLIMETRES (INCHES)**

Foot Mtg.: PV2R24**-L-RAAA-30/3090

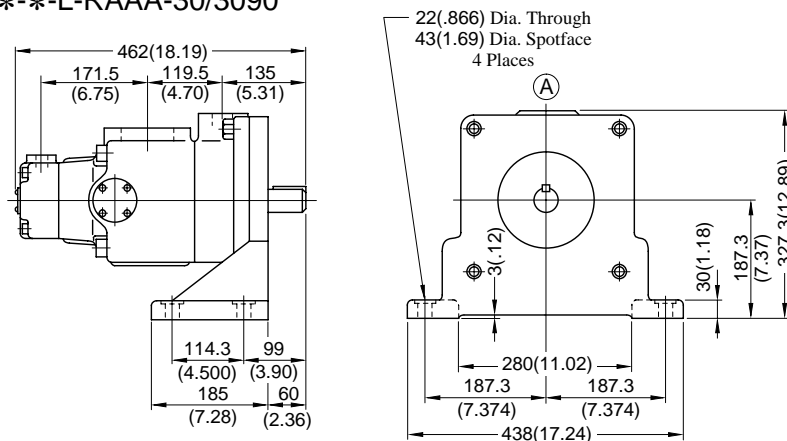

• For other dimensions, refer to "Flange Mtg.".

Flange Mtg.: PV2R34-**-F-REAA-30/3090

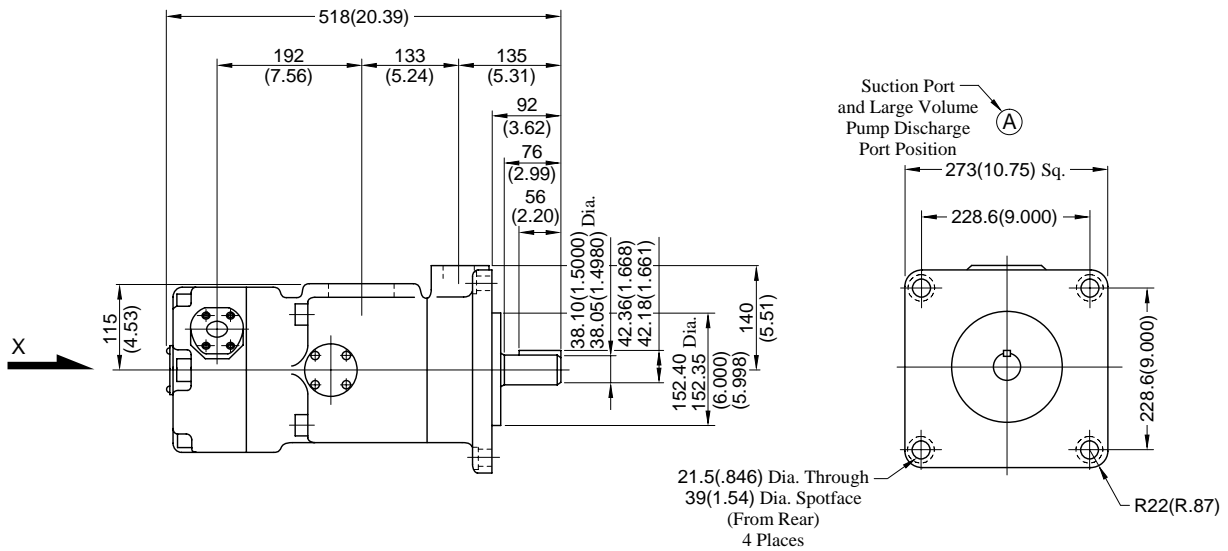
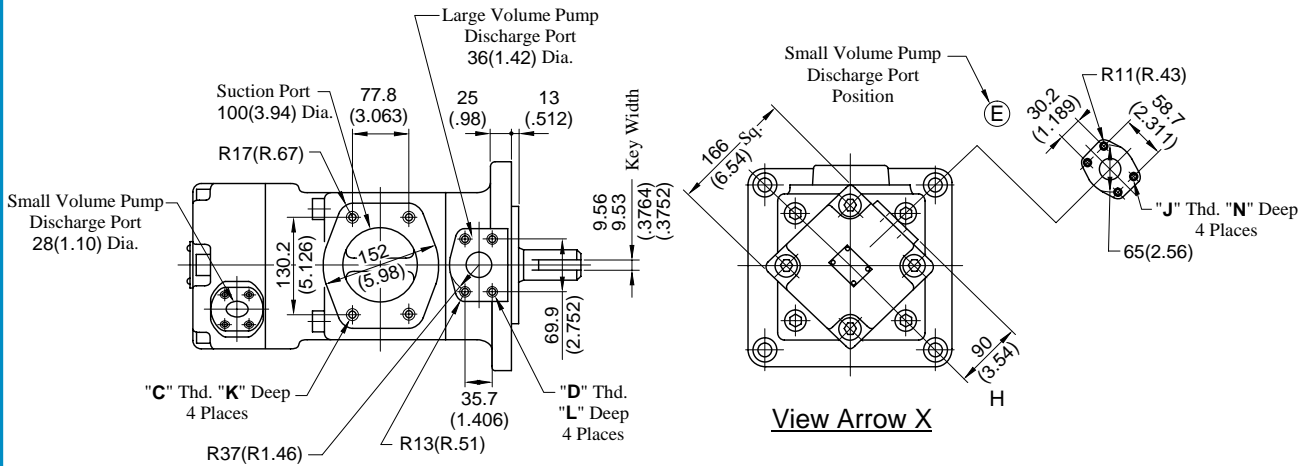

Model Numbers	"C" Thd.	"D" Thd.	"J" Thd.	Dimensions mm (Inches)		
				K	L	N
PV2R34-**-F-REAA-30	M16	M12	M8	19 (.75)	19 (.75)	19 (.75)
PV2R34-**-F-REAA-3090	5/8-11 UNC	1/2-14 UNC	7/16-14 UNC	21 (.83)	21 (.83)	20 (.79)

DIMENSIONS IN MILLIMETRES (INCHES)

Foot Mtg.: PV2R34-**-L-REAA-30/3090

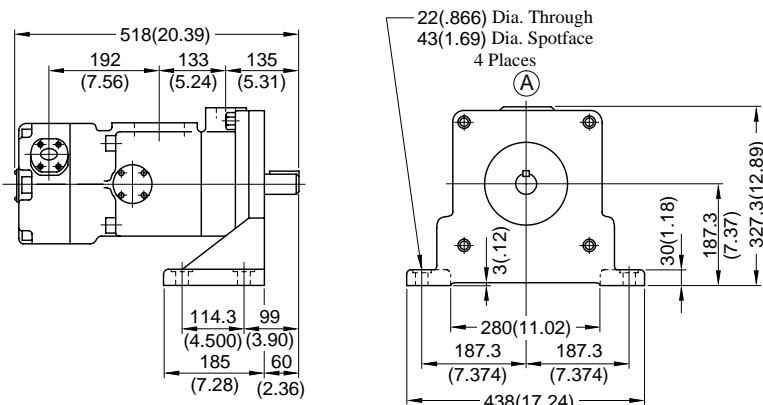

• For other dimensions, refer to "Flange Mtg.".

Viscosity 20 mm²/s (100 SSU) [ISO VG32 Oils, 50°C (122°F)]

- PV2R12-*-26
- PV2R24-26-*

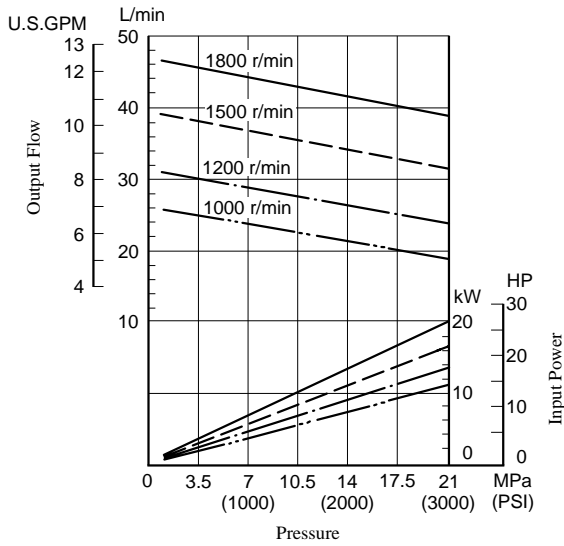

- PV2R12-*-33
- PV2R24-33-*

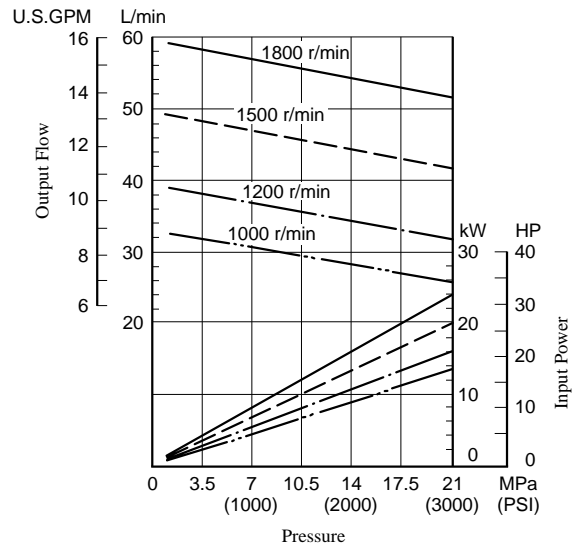

- PV2R23-*-52
- PV2R34-52-*

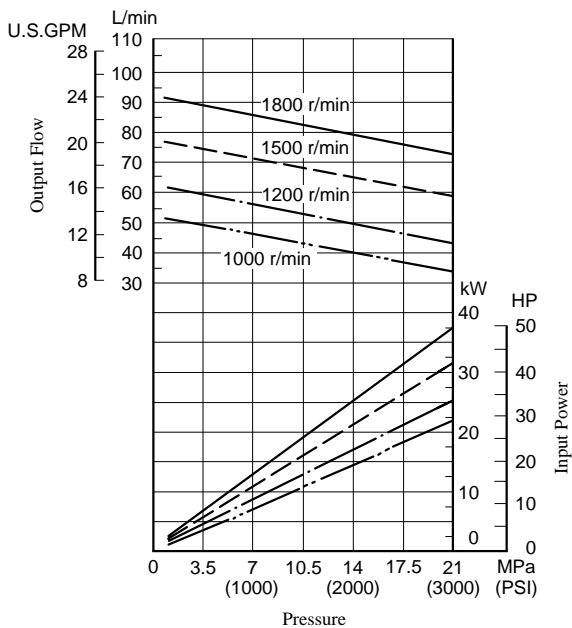

- PV2R23-*-60
- PV2R34-60-*

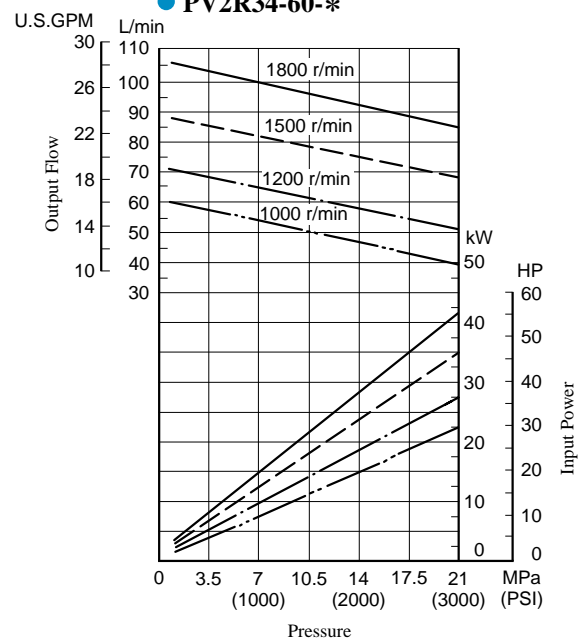

Viscosity 20 mm²/s (100 SSU) [ISO VG32 Oils, 50°C (122°F)]

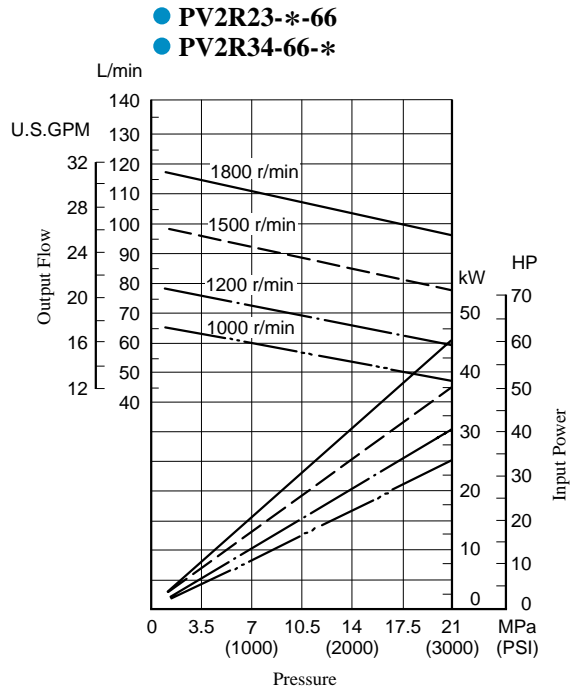

Spare Parts List

PV2R12-**-**-REAA-40/4090
 PV2R13-**-**-RAAA-40/4090
 PV2R23-**-**-REAA-40/4090
 PV2R33-**-**-RAAA-30/3090

CAUTION

When making replacement of seals, bearing or cartridge kits, please do it carefully after reading through the relevant instructions in the Operator's Manual.

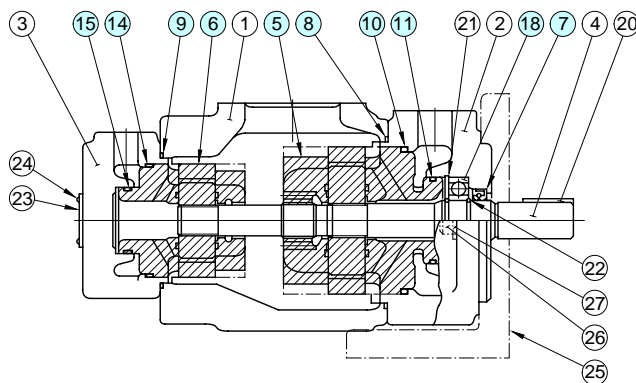

Cartridge Kits

Model Numbers	Cartridge Kit Numbers		Model Numbers	Cartridge Kit Numbers	
	⑥ Small Volume Pump	⑤ Large Volume Pump		⑥ Small Volume Pump	⑤ Large Volume Pump
PV2R12-6-★-**-REAA-40*	CPV2R13-6-L-40	CPV2R2 -★-R-40	PV2R13-6-★-**-RAAA-40*	CPV2R13-6-L-40	CPV2R3 -★-R-30
PV2R12-8-★-**-REAA-40*	CPV2R13-8-L-40		PV2R13-8-★-**-RAAA-40*	CPV2R13-8-L-40	
PV2R12-10-★-**-REAA-40*	CPV2R13-10-L-40		PV2R13-10-★-**-RAAA-40*	CPV2R13-10-L-40	
PV2R12-12-★-**-REAA-40*	CPV2R13-12-L-40		PV2R13-12-★-**-RAAA-40*	CPV2R13-12-L-40	
PV2R12-14-★-**-REAA-40*	CPV2R13-14-L-40		PV2R13-14-★-**-RAAA-40*	CPV2R13-14-L-40	
PV2R12-17-★-**-REAA-40*	CPV2R13-17-L-40		PV2R13-17-★-**-RAAA-40*	CPV2R13-17-L-40	
PV2R12-19-★-**-REAA-40*	CPV2R13-19-L-40		PV2R13-19-★-**-RAAA-40*	CPV2R13-19-L-40	
PV2R12-23-★-**-REAA-40*	CPV2R13-23-L-40		PV2R13-23-★-**-RAAA-40*	CPV2R13-23-L-40	
PV2R12-25-★-**-REAA-40*	CPV2R13-25-L-40		PV2R13-25-★-**-RAAA-40*	CPV2R13-25-L-40	
PV2R12-31-★-**-REAA-40*	CPV2R13-31-L-40		PV2R13-31-★-**-RAAA-40*	CPV2R13-31-L-40	
PV2R23-41-★-**-REAA-40*	CPV2R23-41-L-40	CPV2R33 -★-R-30	PV2R33-76-★-**-RAAA-30*	CPV2R33-76-L-30	CPV2R33 -★-R-30
PV2R23-47-★-**-REAA-40*	CPV2R23-47-L-40		PV2R33-94-★-**-RAAA-30*	CPV2R33-94-L-30	
PV2R23-53-★-**-REAA-40*	CPV2R23-53-L-40		PV2R33-116-★-**-RAAA-30*	CPV2R33-116-L-30	
PV2R23-59-★-**-REAA-40*	CPV2R23-59-L-40				
PV2R23-65-★-**-REAA-40*	CPV2R23-65-L-40				

Note: Each **ab**ove is a space for large volume pump nominal displacement. Referring to the model No. designation on page 18, write the correct nominal displacement figures.

Seals & Bearings

Item	Name of Parts	Part Numbers				Qty.
		PV2R12	PV2R13	PV2R23	PV2R33	
7★	Oil Seal	ISD 30 42 8	ISD 35 55 11	ISD 35 55 11	ISD 35 55 11	1
8★	O-Ring	SO-NB-G105	SO-NB-G135	SO-NB-G135	SO-NB-G135	1
9★	O-Ring	SO-NB-G80	SO-NB-G80	SO-NB-G105	SO-NB-G135	1
10★	O-Ring	SO-NB-G85	SO-NB-G115	SO-NB-G115	SO-NB-G115	1
11★	O-Ring	SO-NB-P46	SO-NB-A231	SO-NB-A231	SO-NB-A231	1
14★	O-Ring	SO-NB-G60	SO-NB-G60	SO-NB-G85	SO-NB-G115	1
15★	O-Ring	SO-NB-G30	SO-NB-G30	SO-NB-P46	SO-NB-A231	1
18	Bearing	6205	6207	6207	6207	1
19	Bearing	—	—	—	6305	1

Note: 1) The o-rings under item. Nos. 10 and 11 are included in the large volume pump cartridge kit and those under item. Nos. 14 and 15 in the small volume pump cartridge kit.

2) For pumps for phosphate ester type hydraulic fluids, different part Nos. are used. Please contact us.

★ When ordering seals, please specify the seal kit number from the table right.

Pump Model Numbers	Seal Kit Numbers
PV2R12-**-**-REAA-40*	KS-PV2R12-40
PV2R13-**-**-RAAA-40*	KS-PV2R13-40
PV2R23-**-**-REAA-40*	KS-PV2R23-40
PV2R33-**-**-RAAA-30*	KS-PV2R33-30

Spare Parts List

PV2R14-***-RAAA-30/3090
PV2R24-***-RAAA-30/3090
PV2R34-***-REAA-30/3090

CAUTION

When making replacement of seals, bearing or cartridge kits, please do it carefully after reading through the relevant instructions in the Operator's Manual.

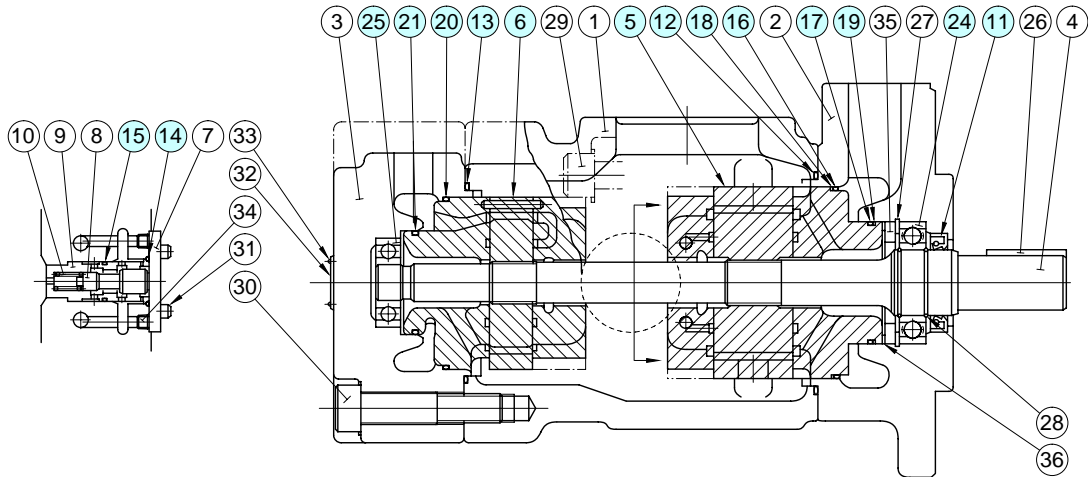

● Cartridge Kits

Model Numbers	Cartridge Kit Numbers		Model Numbers	Cartridge Kit Numbers	
	⑥ Small Volume Pump	⑤ Large Volume Pump		⑥ Small Volume Pump	⑤ Large Volume Pump
PV2R14-6-★-*-RAAA-30*	CPV2R13-6-L-30	CPV2R2 ★-R-40	PV2R24-26-★-*-RAAA-30*	CPV2R23-26-L-30	CPV2R4 ★-R-30
PV2R14-8-★-*-RAAA-30*	CPV2R13-8-L-30		PV2R24-33-★-*-RAAA-30*	CPV2R23-33-L-30	
PV2R14-10-★-*-RAAA-30*	CPV2R13-10-L-30		PV2R24-41-★-*-RAAA-30*	CPV2R23-41-L-30	
PV2R14-12-★-*-RAAA-30*	CPV2R13-12-L-30		PV2R24-47-★-*-RAAA-30*	CPV2R23-47-L-30	
PV2R14-14-★-*-RAAA-30*	CPV2R13-14-L-30		PV2R34-52-★-*-REAA-30*	CPV2R33-52-L-30	CPV2R34 ★-R-30
PV2R14-17-★-*-RAAA-30*	CPV2R13-17-L-30		PV2R34-60-★-*-REAA-30*	CPV2R33-60-L-30	
PV2R14-19-★-*-RAAA-30*	CPV2R13-19-L-30		PV2R34-66-★-*-REAA-30*	CPV2R33-66-L-30	
PV2R14-23-★-*-RAAA-30*	CPV2R13-23-L-30		PV2R34-76-★-*-REAA-30*	CPV2R33-76-L-30	
		PV2R34-94-★-*-REAA-30*	CPV2R33-94-L-30		
		PV2R34-116-★-*-REAA-30*	CPV2R33-116-L-30		

Note: The ★ marks are spaces for large volume pump nominal displacements. Referring to the model No. designation on page 18, write correct nominal displacement figures.

● Seals & Bearings

Item	Name of Parts	Part Numbers			Qty.
		PV2R14	PV2R24	PV2R34	
11★	Oil Seal	ISD 45 68 12	ISD 45 68 12	ISD 45 68 12	1
12★	O-Ring	SO-NB-G145	SO-NB-G145	SO-NB-G145	1
13★	O-Ring	SO-NB-G80	SO-NB-G105	SO-NB-G135	1
14★	O-Ring	SO-NB-P28	SO-NB-P28	SO-NB-P28	1
15★	O-Ring	SO-NB-P22A	SO-NB-P22A	SO-NB-P22A	1
16★	O-Ring	SO-NA-G130	SO-NA-G130	SO-NA-G130	1
17★	O-Ring	SO-NA-G80	SO-NA-G80	SO-NA-G80	1
18★	Back Up Ring	SO-BE-G130	SO-BE-G130	SO-BE-G130	1
19★	Back Up Ring	SO-BB-G80	SO-BB-G80	SO-BB-G80	1
20★	O-Ring	SO-NB-G60	SO-NB-G85	SO-NB-G115	1
21★	O-Ring	SO-NB-G30	SO-NB-P46	SO-NB-A231	1
24	Bearing	6209	6209	6209	1
25	Bearing	—	—	6305	1

Note: 1) The o-rings and back up rings under item. Nos. 16 to 19 are included in the large volume pump cartridge kit and those under item. Nos. 20 and 21 in the small volume pump cartridge kit.

2) For pumps for phosphate ester type hydraulic fluids, different part Nos. are used. Please contact us.

★ When ordering seals, please specify the seal kit number from the table right.

Pump Model Numbers	Seal Kit Numbers
PV2R14-***-RAAA-30*	KS-PV2R14-30
PV2R24-***-RAAA-30*	KS-PV2R24-30
PV2R34-***-REAA-30*	KS-PV2R34-30



"PV11R" SERIES

Fixed Displacement- Single

PV11R10/PV11R20

VANE PUMPS

Up to 40 MPa (5800 PSI), 22.1 cm³/rev (1.349 CU.IN./rev)

B

These pumps are of completely unique design for extra high pressure applications. The excessive wear to the vanes and camring which usually occurs in shch high pressure vane pumps has been solved by means of adopting the special methods in both mechanical construction aspects and lubrication systems.

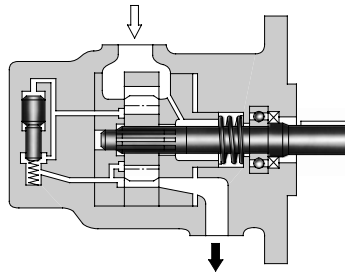
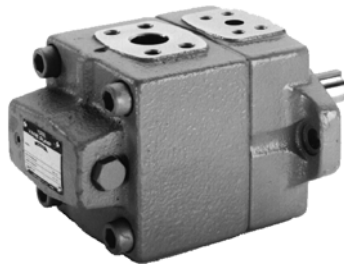

Graphic Symbol

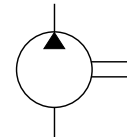

Model Number Designation

F-	PV11R10	-12	-L	-R	A	A	-20	*
Special Seals	Series Number	Nominal Displacement cm ³ /rev	Mounting	Direction of Rotation	Discharge Port Position	Suction Port Position	Design Number	Design Std.
F: For phosphate ester type fluids (Omit if not required)	PV11R10	2 5 7 10 12	L: Foot Mtg.	R: Clockwise ^{★1}	A: Upwards (Normal)	A: Upwards (Normal)	20	Refer to ^{★2}
	PV11R20	15 19 22	F: Flange Mtg.				20	

★1. Available to supply pump with anti-clockwise rotation. Consult Yuken for details. ★2. Design Standards: None.....Japanese Standard "JIS" & European Design Standard 90.....N. American Design Standard

Pipe Flange Kits

Pipe flange kits are available. When ordering, specify the kit number from the table below.

Pump Model Numbers	Name of Port	Pipe Flange Kit Numbers						
		Threaded Connection			Socket Welding		Butt Welding	
		Japanese Standard "JIS"	European Design Standard	N. American Design Standard	Japanese Standard "JIS" European Design Standard	N. American Design Standard	Japanese Standard "JIS" European Design Standard	N. American Design Standard
PV11R10	Suction	F5-08-A-10	F5-08-A-1080	F5-08-A-1090	F5-08-B-10	F5-08-B-1090	F5-08-C-10	F5-08-C-1090
PV11R20	Discharge	—	—	—	F6-04W-B-M-10	F6-04W-B-U-1090	—	—

Note: 1) Special seals (Viton seals) are required when phosphate ester type fluids are used (prefix "F-" to the pipe flange kit number when ordering.).

Note: 2) Details specifications of pipe flange kits are given in the Catalogue No. Pub. EC-3001.

■ Specifications

● Maximum Operating Pressure

Model Numbers	Geometric Displacement cm ³ /rev (CU.IN./rev)	Maximum Operating Pressure MPa(PSI)					
		Petroleum Base Oils		Water Containing Fluids			Synthetic Fluids
		Anti-Wear Type	R & O Type	Anti-Wear ^{*1} Type Water Glycols	Water Glycols	Water in Oil Emulsions	Phosphate Esters
PV11R10-2	2.2 (.134)	31.5 (4570) ^{*2}	25 (3630)	25 (3630)	7 (1020)	7 (1020)	25 (3630)
PV11R10-5	4.5 (.275)						
PV11R10-7	6.8 (.415)						
PV11R10-10	9.7 (.592)						
PV11R10-12	12.1 (.738)						
PV11R20-15	15.2 (.915)	35 (5100)	25 (3630)	25 (3630)	7 (1020)	7 (1020)	25 (3630)
PV11R20-19	19.0 (1.159)						
PV11R20-22	22.1 (1.349)						

★1. For the brands of anti-wear type water-glycols, see the item of "Hydraulic Fluids" on page 3.

★2. For pressures above 25 MPa (3630 PSI), hold the speed above 1450 r/min.

● Shaft Speed Range

Model Numbers	Shaft Speed Range r/min					
	Max.					
	Petroleum Base Oils		Water-Containing Fluids	Synthetic Fluids		Min.
	Anti-Wear Type	R & O Type		Phosphate Esters		
PV11R10-2	3000	1800	1200	1200	950*	
PV11R10-5						
PV11R10-7	2500					
PV11R10-10	2300					
PV11R10-12	2000					
PV11R20-*	1800	1800	1200	1200	800*	

★ For starting at low speed, the maximum viscosity is limited. For details, see the item of "Hydraulic Fluids" on page 3.

● Mass

Model Numbers	Approx. Mass kg(lbs.)	
	Flange Mtg.	Foot Mtg.
PV11R10	16.4 (36.2)	19.4 (42.8)
PV11R20	16.4 (36.2)	19.4 (42.8)

● Output Flow & Input Power

Characteristics are described on the pages as shown on the table below. Please see the pages concerned.

Model Numbers	Typical Pump Characteristics described on the Pages below
PV11R10	5, 6
PV11R20	6

Hydraulic Fluids

1. Type of hydraulic fluids

Any type of hydraulic fluids listed in the Table 1 below can be used. However, the specifications of the pumps such as maximum pressure and maximum pump speed may be changed according to the type of hydraulic fluids to be used. For details, please refer to the specifications of the pump concerned.

● Type of hydraulic fluids (Table 1)

Type of Fluids		Descriptions
Petroleum Base Oils		Use anti-wear type oils or R&O type oils (equivalent to ISO VG32 or 46).
Synthetic Fluids		Use phosphate ester type fluids. When phosphate ester type fluid is used, prefix "F-" to the model number because the special seals (fluororubber) are required to be used.
Water Containing Fluids	Water-Glycols	Standard pumps can be used without conditions. However, if any type other than those in Table 2 is used, the maximum operating pressure is limited.
	Water in Oil Emulsions	Standard pumps can be used without conditions.

● Anti-wear type water-glycols (Table 2)

Fluid Manufacturer	Commercial Trade Name
Mobil	Mobil Hydrofluid HFC 46 Mobil Nybac FR 200 D
JAPAN ENERGY CORP.	JOMO Hydoria
NIPPON OIL CO., LTD	HYRAND FRX 46
Showa Shell Sekiyu K. K.	Irus Fluid C G-W Fluid 46
MATSUMURA OIL RESEARCH CORP.	HYDOL HAW
COSMO OIL CO., LTD.	COSMO FLUID HQ 46 COSMO FLUID GS 46

2. Fluid viscosity and temperature

Use the hydraulic fluids which satisfy the recommended viscosity and oil temperature given in the Table 3 below. However, please note that if any of the pumps listed in the Table 4 is started at low speed, the maximum fluid viscosity is limited.

● Fluid viscosity and temperature (Table 3)

Fluid	Temperature °C (°F)	Viscosity mm ² /s(SSU)
Petroleum Base Oils	0-70 (32-158)	20-400 (100-1800)
Phosphate Esters		
Water Glycols	0-50 (32-122)	
Water in Oil Emulsions	5-50 (41-122)	

● Maximum viscosity for low start-up speed (Table 4)

Pump Type	Start-up Speed r/min	Max. Viscosity mm ² /s (SSU)
PV11R10, PV11R20	600	100 (455)
	950	200 (910)

3. Control of contamination

Contamination of hydraulic fluids results in pump failures and reduced pump lives. Carry out sufficient contamination control for hydraulic fluids and keep contamination level within NAS class 12.

Also, use a 100 μm (150-mesh) tank filter on the suction side, more than 50 mm (2 in.) away from the tank bottom.

Instructions

1. Alignment of shaft

Employ a flexible coupling whenever possible, and avoid any stress from bending or thrust.

Maximum permissible misalignment is less than 0.1 mm (.004 inches) TIR and maximum permissible misangular is less than 0.2°.

2. Suction pressures

Set the suction pressure at pump inlet port at the value given in the table below. Furthermore, use the pipes in the suction side having the diameter as indicated on the installation drawings. In case where the pump is installed on the tank or at the position higher than the tank top cover, the height of the suction port of the pump should be less than 1 metre (3.3 ft.) from the oil level {less than 0.8 metre (2.6 ft.) in case of using phosphate ester fluids or water containing fluids}.

(Table 5)

Model Numbers	Suction Pressure		
	Minimum		Maximum
	Petroleum base oil	Phosphate ester type fluid water containing fluid	
PV11R, PV11R20	-20 kPa (5.9 in. Hg Vacuum)	-16 kPa (4.7 in. Hg Vacuum)	+30 kPa (+4.3 PSIG)

3. Precautions at starting

At an initial operation or at an operation after a long rest, the pump may have difficulty in sucking up fluid. In such cases, an air bleed valve should be installed beforehand on the discharge side (model No. ST1004-*-10*, Catalogue No. Pub. EC-3001.), or discharge air by slightly slackening the connection on the discharge side. At starting, operate the pump intermittently as far as possible with no load.

For fluid viscosity at starting, see the item of "Hydraulic Fluids".

4. Other precautions

If a PV11R series single pump is used at speed below 1200 r/min, install the pump with the suction port upside so that the pump can suck up fluid easily at starting.

Flange Mtg.

PV11R10-**-F-RAA-20/2090

PV11R20-**-F-RAA-20/2090

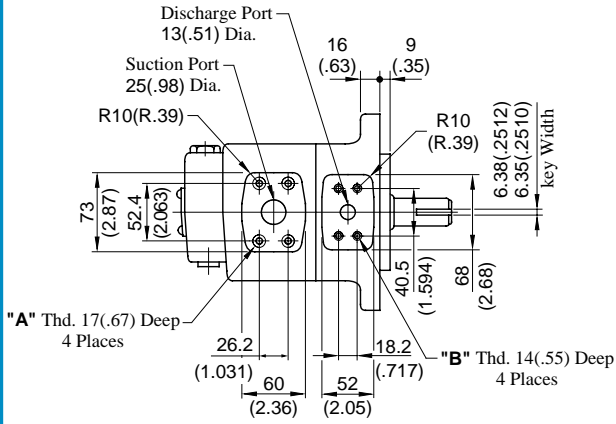

Model Numbers	"A" Thd.	"B" Thd.
PV11R10/PV11R20-**-RAA-20	M10	M8
PV11R10/PV11R20-**-RAA-2090	3/8-16 UNC	5/16-18 UNC

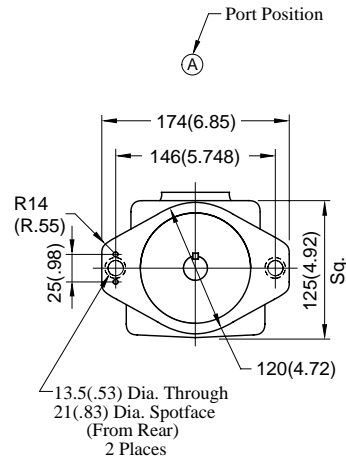
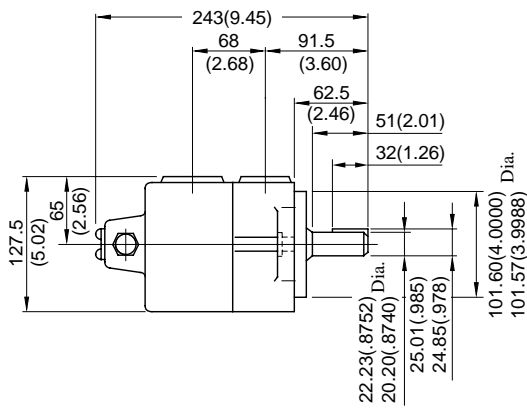

DIMENSIONS IN
MILLIMETRES (INCHES)

Foot Mtg.

PV11R10-**-L-RAA-20/2090

PV11R20-**-L-RAA-20/2090

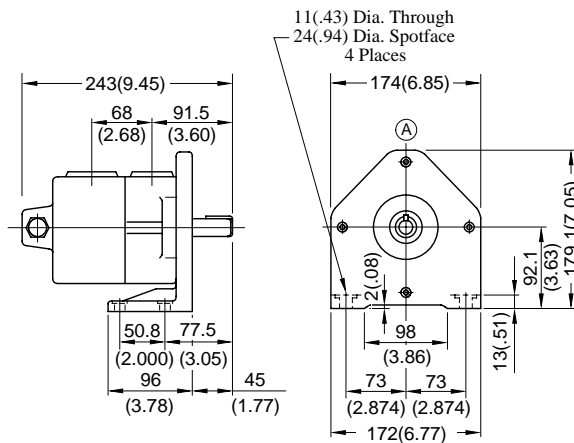

• For other dimensions, refer to "Flange Mtg.".

Viscosity 20 mm²/s (100 SSU) [ISO VG32 Oils, 50°C (122°F)]

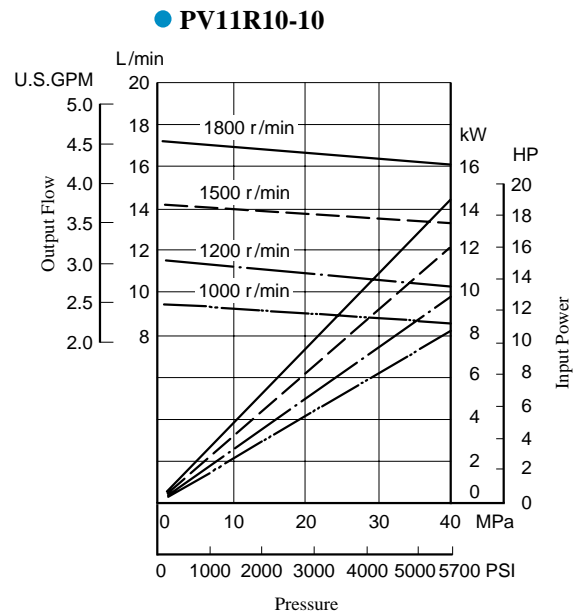
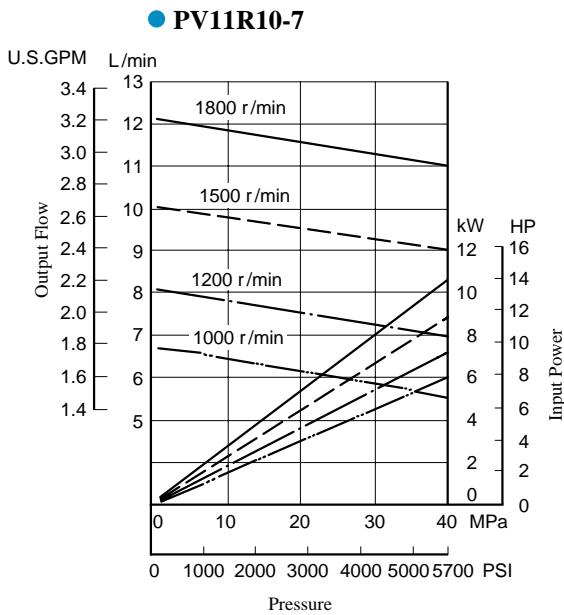
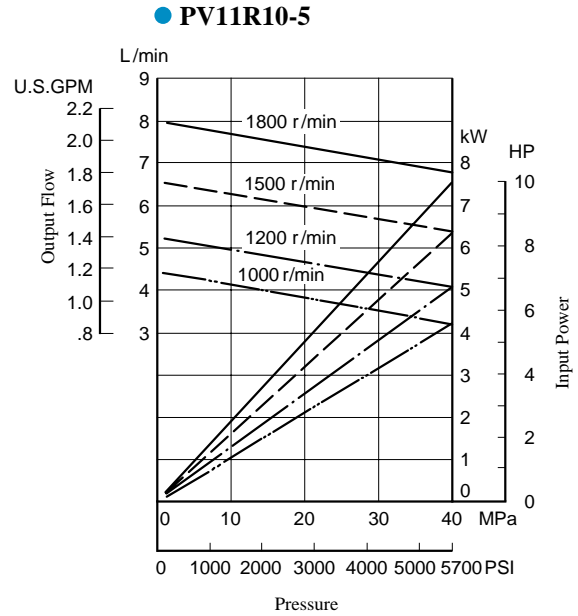
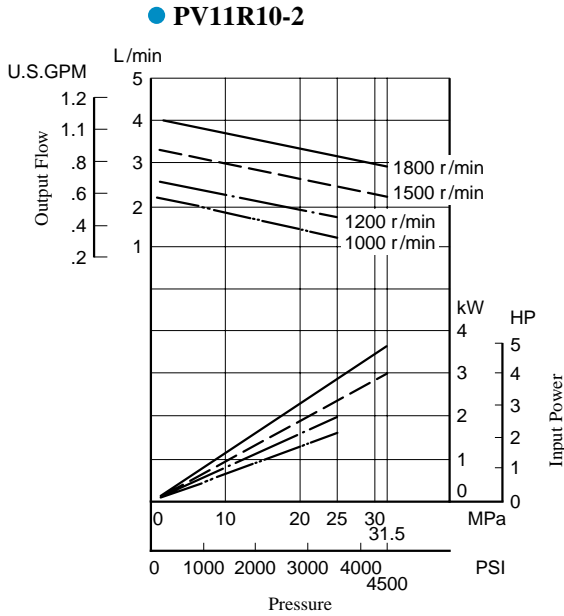

Viscosity 20 mm²/s (100 SSU) [ISO VG32 Oils, 50°C (122°F)]

● PV11R10-12

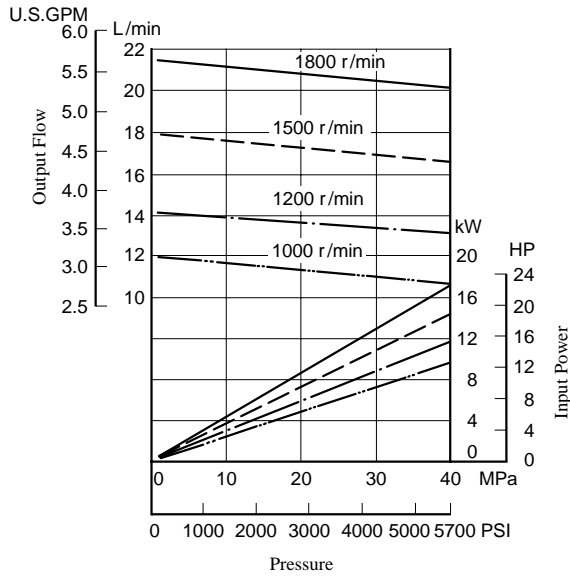

● PV11R20-15

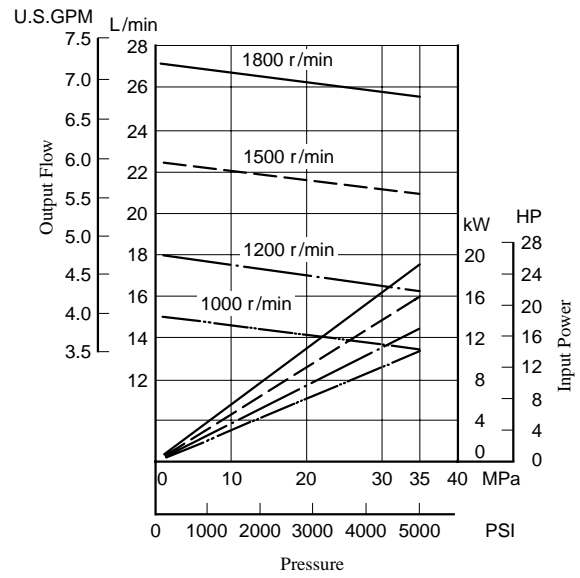

● PV11R20-19

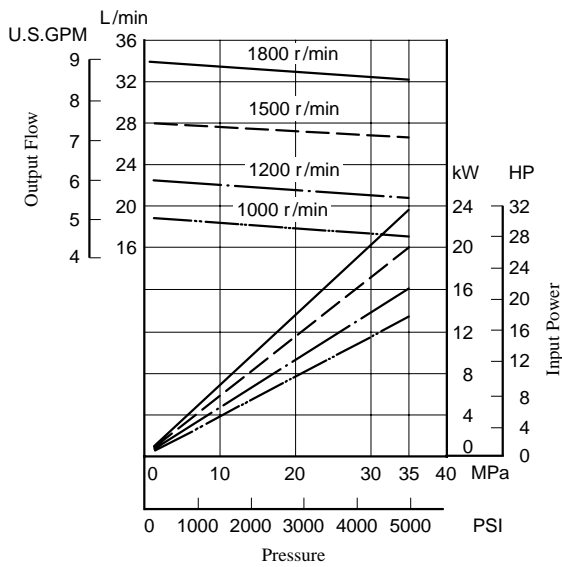

● PV11R20-22

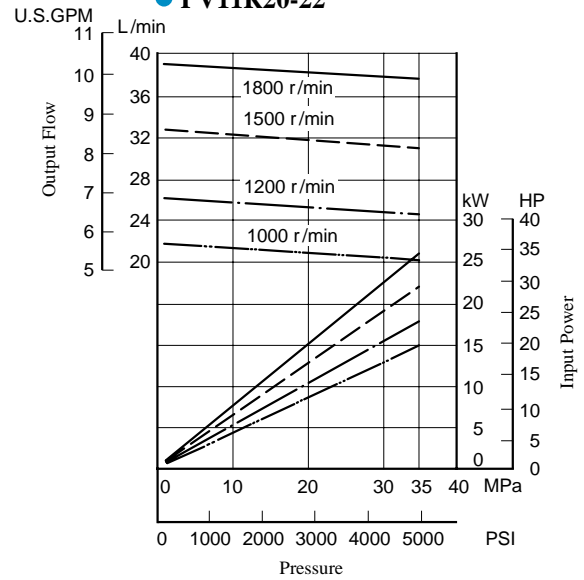

PV11R10-**-**-RAA-20/2090
PV11R20-**-**-RAA-20/2090

⚠ CAUTION

When making replacement of seals, bearings or cartridge kits, please do it carefully after reading through the relevant instructions in the Operator's Manual.

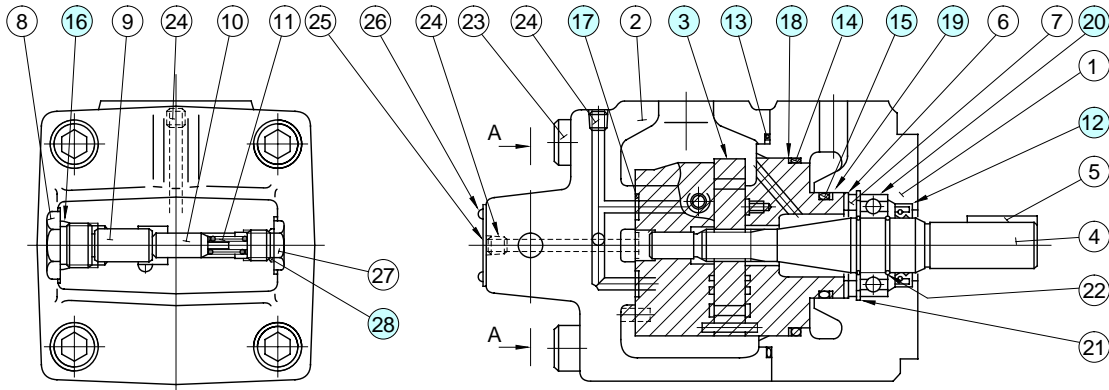

Section A-A

● Cartridge Kits

Model Numbers	③ Cartridge Kit No.
PV11R10-2-**-**-RAA-20/2090	CPV11R10-2-R-20
PV11R10-5-**-**-RAA-20/2090	CPV11R10-5-R-20
PV11R10-7-**-**-RAA-20/2090	CPV11R10-7-R-20
PV11R10-10-**-**-RAA-20/2090	CPV11R10-10-R-20
PV11R10-12-**-**-RAA-20/2090	CPV11R10-12-R-20
PV11R20-15-**-**-RAA-20/2090	CPV11R20-15-R-20
PV11R20-19-**-**-RAA-20/2090	CPV11R20-19-R-20
PV11R20-22-**-**-RAA-20/2090	CPV11R20-22-R-20

● Seals & Bearing

Item	Name of Parts	Part Numbers	Qty.
		PV11R10, PV11R20	
12*	Oil Seal	ISD 25 38 8	1
13*	O-Ring	SO-NB-G95	1
14*	O-Ring	SO-NB-G75	1
15*	O-Ring	SO-NB-P42	1
16*	O-Ring	SO-NB-P18	1
17*	O-Ring	SO-NB-P9	3
18*	Back Up Ring	SO-BE-G75	1
19*	Back Up Ring	SO-BB-P42	1
20	Bearing	6005	1
28*	O-Ring	SO-NB-P11	1

Notes: 1) Item Nos. ⑭, ⑮ and ⑰ (o-rings) and ⑱ and ⑲ (back up rings) are included in the cartridge kit.

2) For pumps for phosphate ester type hydraulic fluids, different cartridge kit and seals from the above are used. Please contact us.

★ When ordering seals, please specify the seal kit number (Kit No.: KS-PV11R10-20).