

# Load holding valves type LHK, LHDV, and LHT

Load holding valves are pressure valves, which act always on the return flow side of double acting consumers. They block the return duct according to their set pressure (setting approx. 15% above the max. load pressure) generating a counter force to a pushing (negative) load. Therefore the pump will have to feed the inflow side, e.g. pressurizing the cylinder enough to overcome the set pressure of the load holding valve, thereby dropping the load.

Type LHK is intended for applications which are hardly prone for oscillations.

Type LHT features simple, whereas type LHDV an elaborate special dampening equipment making them especially suited for applications together with prop. directional spool valves ("Load Sensing" spool valves) e.g. type PSL/PSV.

Many additional options are available such as shock valves, shuttle valves with or without by pass check valve (e.g. delayed release of hydraulic brakes) etc.



**Nomenclature:** Load holding valve (over center valve, for one sided or alternating load direction)  
Single or twin valve

**Design:** Individual valve for pipe connection  
Individual valve  
Manifold mounting  
Screw-in valve  
Version for banjo bolt mounting

**$p_{max}$ :** 360...450 bar

**$Q_{max}$ :** 250 lpm

## Basic types and general parameters

Basic type and size	Flow $Q_{max}$ (lpm)	Oper. pressure $p_{max}$ (bar)	Release ratio	Tapped ports (BSPP)
LHK 22	20	400	1 : 4.6	G 3/8
LHK 33	60	360	1 : 4.4	G 1/2
LHK 44	100	350	1 : 4.4	G 3/4
LHDV 33	80	420	1 : 8...1 : 1.2 <sup>1)</sup>	G 1/2
LHT 2	20	400	1 : 8...1 : 4 <sup>1)</sup>	G 1/4
LHT 3	130	450	1 : 7...1 : 0.53 <sup>1)</sup>	G 1/2
LHT 5	250	450	1 : 6...1 : 0.79 <sup>1)</sup>	G 1

<sup>1)</sup> Release ratio can be altered simply by changing the orifice

**Symbols** (due to the various versions, only a few are illustrated here)

LHK 33 G-15-...

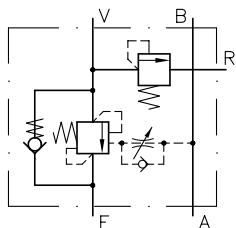

LHT 33 P-11-...

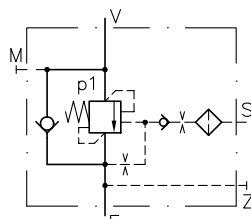

LHDV 33 G-25WD-...

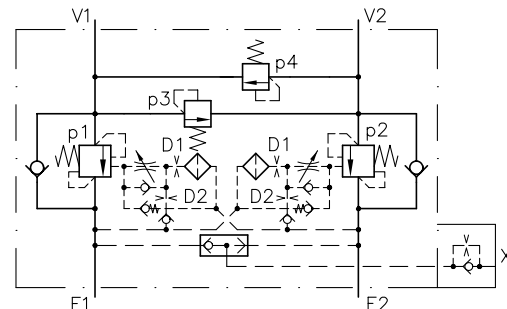

LHK 44 G-21-...

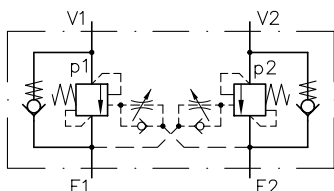

LHT 21 H-14-...

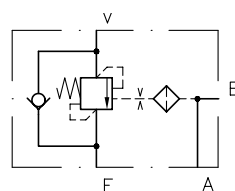

**Additional versions**

- Some available with release ratio 1 : 2 and 1 : 7 (type LHK)
- Release ratio may be altered with different orifice combinations in the range between 1 : 1.2 and 1 : 8.9 (type LHDV and LHT)
- Various housing designs available
- Type LHT is also available completely load pressure independent (line rupture function)

- Versions with shock and suction valves
- Versions with shuttle valve for hydraulic brakes
- Screw-in valves
- Assembly kits
- Type LHTZ with heavy dampening
- Type LHTE, return pressure compensated

**Order examples**

**LHK 44 G - 11 - 160**

Load holding valve (single valve no shock valve) type LHK 44, damped version (coding G, standard)  
 Load holding pressure factory set to 160 bar

**LHDV 33 - 25 WD - B 6 - 200/200 - 240/240**

Load holding valve (twin valve) type LHDV 33, with shock valve and shuttle valve / by-pass check valve (coding WD), valve suited for approx. 60 lpm (coding B), orifice D2 Ø 0.6 mm (resulting release ratio 1:2.9 (standard), coding 6), load holding pressure factory set to 200 bar for both, shock valve factory set to 240 bar for both.

**Dimensions**

Many differing versions are available, therefore only two versions (acc. to the order examples) are illustrated below

**Type LHK 44 G - 11 - 160**

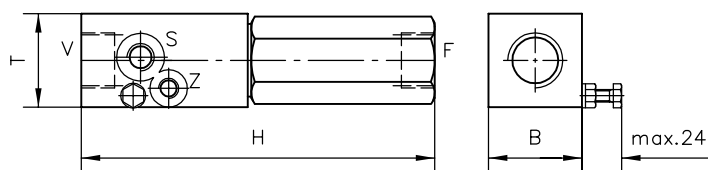

**Type LHT 33 P - 15**

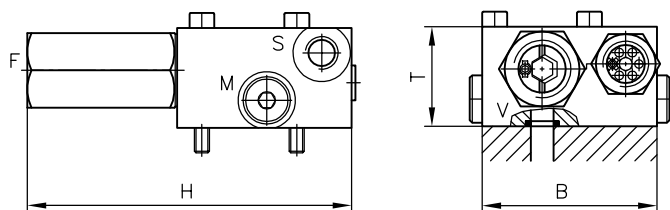

All dimensions in mm, subject to change without notice!

**Type LHDV 33 - 25 WD - B 6 - 200/200 - 240/240**

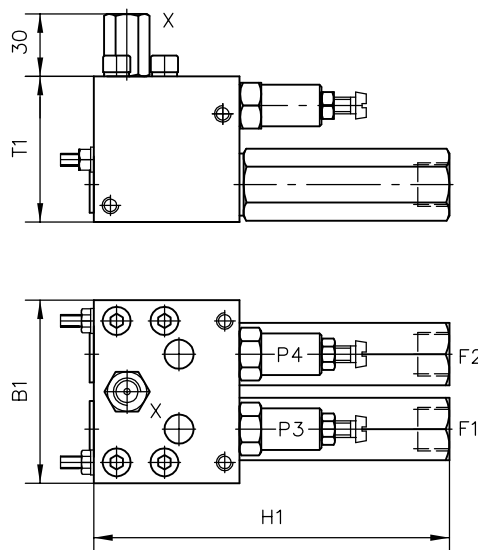

**Basic type**

(single valve)	H	B	T	m (kg)
LHK 22 G-11	97	32	32	0.5
LHK 33 G-11	123	40	40	1.0
LHK 44 G-11	170	45	45	1.6
LHDV 33 P-11 1)	170	50	40	1.8
LHT 33 P-15 1)	128	70	40	1.6
LHT 50 G-11 1)	113	50	50	1.0

**Basic type**

(twin valve)	H1	B1	T1	m (kg)
LHK 22 G 1)	98	60	30	0.9
LHK 33 G 1)	125...291	80	40...60	2.7
LHK 44 G 1)	170	90	50	3.5
LHDV 33	170	88	70	4.7
LHT 20 P-23	132	40	24.8	1.2
LHT 21 G-21	132	50	24.8	0.8

1) Note: Design may be significantly different to the illustrated version!

**Additional information**

- Load holding valves type LHK D 7100
- type LHDV D 7770
- type LHT D 7918
- Prop. directional spool valves type PSL/PSV D 7700-2
- type PSL/PSV D 7700-3
- type PSL/PSV D 7700-5
- type PSLF/PSVF D 7700-F

- See also section "Devices for special applications" (Industrial trucks, Mobile hydraulics, Screw-in valves and installation kits)

For page and section of the devices additionally listed, see type index