

Lifting modules and lifting/lowering valves type HMB, HMC, HMT, and HSV, HZV etc.

These lifting modules and lifting/lowering valves were developed especially for the actuation of hoists e.g. turret trucks, order pickers, reach trucks and walkie stackers. They consist of a combination of various valve types (flow control valves, throttles, directional valves) suited for the control of the main lift and for other additional functions. The internal control layout of the main valve is very flexible and can be tailored to meet exactly the requirements of the drive concept (constant delivery or speed controlled pump) as well as the intended application.

This valve design can cope also with additional functions being required by simply adding directional seated or directional spool valve sections (e.g. type SWR or SWS) to the main valve body.



Nomenclature: Valve combination consisting of (depending on type):

- 3-way flow control valve
- 2-way flow control valve
- 2-way seated valves
- Directional spool valves

Design: Individual valve
Connection block for valve banks

Actuation: Solenoid

P_{max} : 315 bar

Q_{max} : 120 lpm

2 Selection table

2 Field of application and drive concept

Device type	Drive concept			Application					
	①	②	③	Scissor lift	Miniature stacker, Walkie stacker	Counter balance truck	Reach truck	Order picker (warehouse) (no man aloft)	(man aloft)
HSV	•			•	•				
HZV	•			•	•				•
HSN			•					•	•
HST	•	•			•	(•)			•
HMB	(•)	•			(•)			•	•
HMC	•				(•)			•	•
HMT		•				•	•		•
HMS	•	•	•					•	•
HMF	•	•	•					•	•
HMR		•	•					•	•
SWR..SE	•	•					•	•	•
HSW	•				•				

① Constant delivery pump, lifting/lowering via flow controller (throttle)

② Lifting via speed controlled pump, lowering via flow controller (throttle)

③ Lifting/lowering via speed controlled pump

Basic types and main parameter

Type	Flow Q_{max} (lpm)	Pressure p_{max} (bar)	Note	Tapped ports DIN ISO 228/1 (BSPP)	
HSV 21	20	315	Individual devices	P, R, A = G 3/8	
HSV 22	30			P = G 3/8; A, R = G 1/2	
HSV 41	40			P, R, A = G 1/2	
HSV 61	60			P, R, A = G 1/2	
HSV 71	120			P, R, A = G 3/4	
HZV 21	20			P, R, H, J = G 3/8	
HSN	50 ... 100			H, R = G 3/4; P1 = G 3/8; P = (flange connection)	
HST 2	20 ... 40			Connection blocks of lifting module Add-on components: • SWR/SWS - Valve sections • Intermediate blocks • End plates	P, R, H = G 1/2; M = G 3/8
HST 3	30 ... 60				P, R, H = G 3/4; M = G 3/8
HMB 2 1)	30				P, R = G 1/2; M = G 1/4
HMB 33	90	P, R = G 3/4; M, R1 = G 1/4			
HMC 2 1)	30	P, R, A = G 1/2; M = G 1/8			
HMC 3 (33)	90	P, R = G 3/4; M, R1 = G 1/4; C = G 3/8			
HMT 3	70 - 90	H, P, R = G 1/2; M = G 3/8			
HMT 34	70 - 90	H = G 3/4; P, R = G 1/2; M = G 3/8			
HMTL 23	40	H, P, R = G 1/2; A, B, A1, B1 = G 1/4; M = G 3/8; H1, R1 = G 1/8			
HMTL 34	80	H, R = G 3/4; P = G 1/2; A, B, A1, B1 = G 1/4; M = G 3/8			
HMS 4	100	R = G 3/4; C, R1 = G 3/8; M = G 1/4			
HMF 4	100	R = G 3/4; C, R1 = G 3/8; M = G 1/4			
HMR 4	100	P, R1, R2 = G 3/4; P1, D = G 3/8; M = G 1/4			
HSW 2	25	H, R = G 1/2; P1, P2 = G 3/8; M = G 1/8			
SWR 1 SE 1) 2)	12	P, R, R1 = G 1/4; M = G 1/8			
SWR 2 SE 2)	25	P, R = G 3/8; M = G 1/4			

1) Hole pattern SWR 1, T2; adaptor plates from X12 to SWR 2
2) Also for external additional functions

Symbols

Single devices:

Lifting modules and connection blocks:

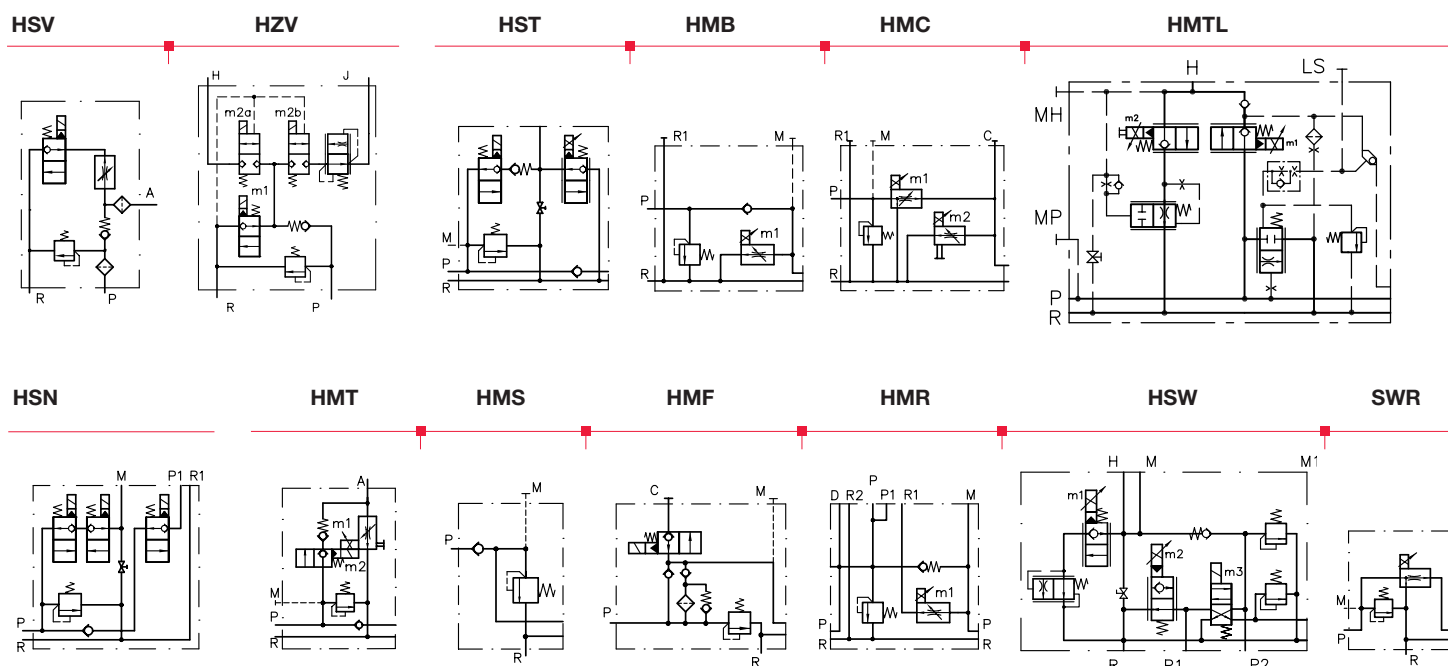

Further versions

- Connection blocks type SWR... with flow divider
- Connection blocks type SWR... with shut-off valves for P and H (lifting)
- Connection blocks type SWR... with/without pressure limiting valve

Symbols

Intermediate blocks (main and initial lift)

Size 2 ³⁾

Size 3 ⁴⁾

T 23

T 2

T 3, T 34, T 44

T 25

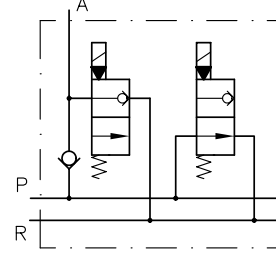
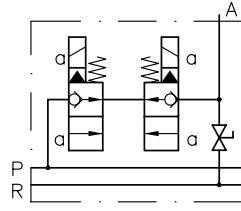
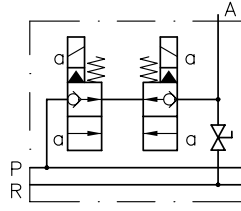
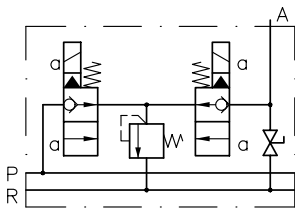

- 3) Hole pattern SWR 1
- 4) Hole pattern SWR 2 / SWS 2

Additional versions (intermediate blocks)

- Various intermediate blocks for turret forks at order pickers; function rotate / reach / lifting / lowering

- Directional spool valve sections type SWR1 with additional functions; Directional spool valve sections type SWS 2 (see also "Additional information")

End plates

Basic type

1

2

20E

30E

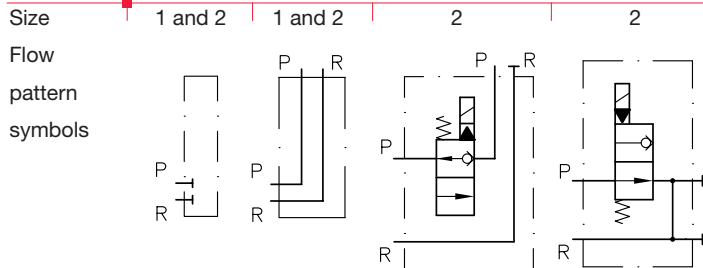

Additional versions (end plates)

- End plates with two pump ports and one return port
- End plates with proportional idle circulation valve
- End plate with solenoid valves to the control of a parking brake

Order examples

HMT 34-1/200-70F -G/M/0/2 AN40 BN130

-D/M/0/02

-30E-P12/G 24

Lifting module type HMT, size 3, port size 4 with pressure limiting valve (set for 200 bar), outflow controller with 70 lpm metering throttle (blocked in idle position); section G with shock and suction valves is part of the ancillary block (settings 40 and 130 bar); end plate with idle circulation valve (open in idle position), proportional-solenoid voltage for the flow control valve 12V DC, solenoid voltage for directional spool valve and directional seated valves 24V DC.

HMC 33-1/150-50/80F-T3 T3/D-20E-G 24

Lifting module type HMC, size 3, port size 3 (G 3/4 (BSPP)) with pressure limiting valve (set for 150 bar), 3-way flow control valve with metering throttle up to 50 lpm, 2-way flow controller up to 80 lpm (blocked in idle position), two intermediate blocks type T3 with seated valves and one directly added directional spool valve section type SWR 2 flow pattern D, end plate with additional port P and R as well as a shut off valve for port P, solenoid voltage 24V DC.

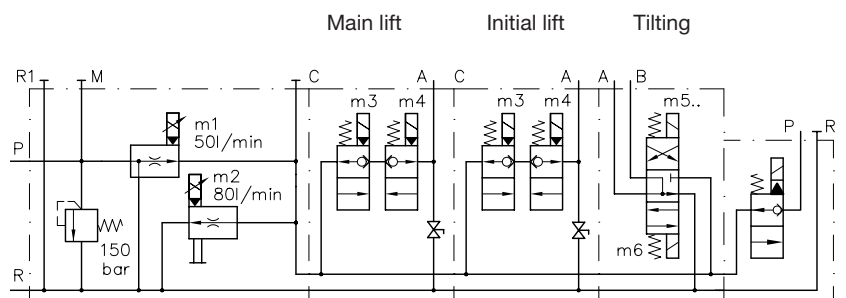
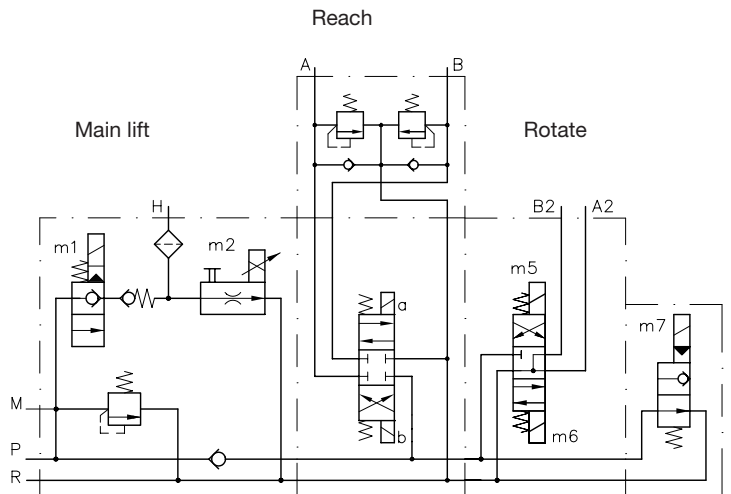

Dimensions

(see order examples)

Type HMT 34 ...

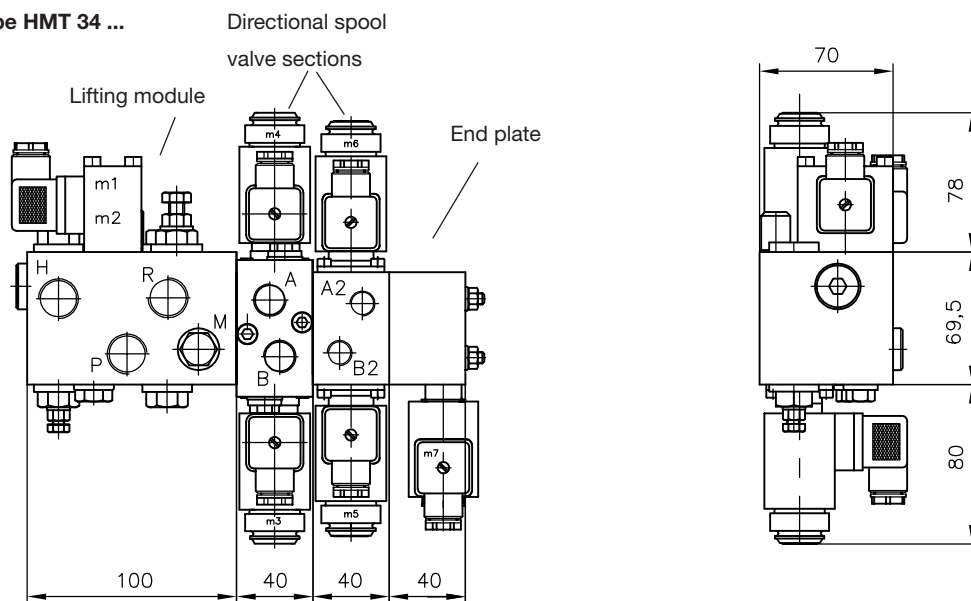

Type HMC 33 ..

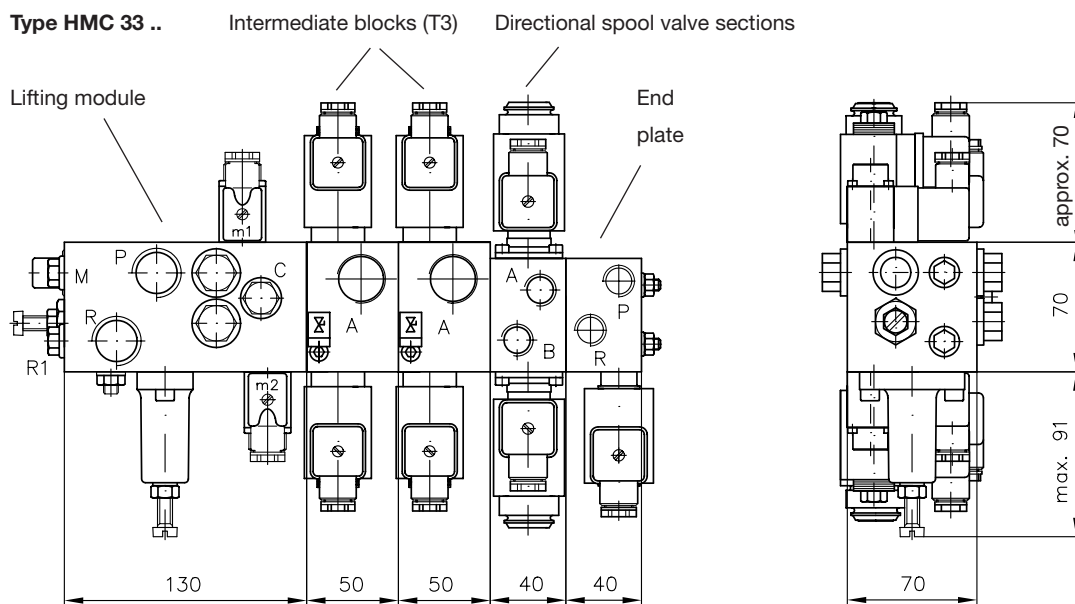

All dimensions in mm, subject to change without notice!

Basic type	m (kg)	Note
HMT 34	approx. 3.8	Main dimensions and weight of the missing lifting modules (basic types) on inquiry!
HMC 33	approx. 5.0	

Additional information

- Lifting module
 - type HMC D 7650
 - type HMT Sk 7758 HMT
 - type HMB Sk 7650 B2, Sk 7650 B33
 - type HST Sk 7650 HST ++
 - type HSW Sk 7650 HSW
 - type HTML Sk 7982 HTML
 - Directional spool valve
 - type SWR D 7450, D 7451
 - type SWS 2 D 7951
 - Information on additional lifting modules on inquiry
 - Plugs with LED's and others D 7163
 - Plugs with economy circuit D 7813, D 7833
 - See also section "Devices for special applications" (Devices for industrial trucks and hoists)
- For page and section of the devices additionally listed, see type index