



POWER AMPLIFIERS / SETTING ADJUSTERS FOR PROPORTIONAL ELECTRO-HYDRAULIC CONTROL VALVES

PROPORTIONAL CONTROLS

Power Amplifiers

These are power amplifiers to be used exclusively to operate the electro-hydraulic proportional valves. Various type and models on available for a variety of applications.



Type	Model Numbers	Applicable to Control Valve	Function	Page
DC Input	AME-D-10-*-20	Pressure and Flow Control (For 10 Ω Sol.)	By giving the command of DC voltage (0-10 V) to the amplifier, current in proportion to that voltage will flow into the solenoid of the control valve in order to control pressure or flow rate. An external setting unit which makes the command voltage of 0-10 V and a DC power supply (or a function generator) are necessary, but if a variable resistor for external setting is only one, the internal power supply for amplifier can be used.	3
	AME-D-S-*-32	Flow Control (For 40 Ω Sol.)		9
	AME-D2-H1-*-12	Pressure and Flow Control (For 40 Ω-10 Ω Sol.)		14
	AME-D2-1010-*-10	Pressure and Flow Control (For 10 Ω-10 Ω Sol.)		14
DC Input-Feedback	SK1022-*-11	Pressure and Flow Control (For 10 Ω Sol.)	Basically, this is a DC input type with a feedback operating unit. This is for high-accuracy control and used to feedback the pressure or flow rate converted to electric signals.	3
	AME-DF-S-*-22	Flow Control (For 40 Ω Sol.)		9
Slow Up-Down	AME-T-S-*-22	Flow Control (For 40 Ω Sol.)	A slow up-down signal generator and the functions of a DC input type are incorporated. This is used to control the pressure or flow rate by slow up-down pattern and the command signals are given by relay contacts, limit switches, timer contacts, etc.	9
DC Input For DC Power 24 V DC	SK1015-11	Pressure and Flow Control (For 10 Ω Sol.)	An amplifier which is operated by a battery power supply (24V). By giving the command of DC voltage to the amplifier, current in proportion to that voltage will flow in the solenoid of the control valve in order to control pressure or flow rate.	3
	AMN-D-10			An external setting unit which makes the command voltage and a DC power supply (or a function generator) are necessary, but if a variable resistor for external setting is only one, the internal power supply for amplifier can be used.
	SK1091-D24-10	Directional and Flow Control	SK1015 amplifier can be used in automobile construction machine.	18

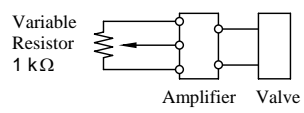

■ Setting Adjusters

The setting adjuster supplies the command signal voltage to the power amplifier. Since the setting adjuster is closely related to actual machine operating procedure, the user generally provides this device.

Yuken makes the following standard setting adjusters for general use and designs and manufactures special setting adjusters to order:

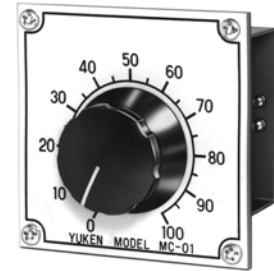

Type	Model Numbers	Function	Page
Manually Operated Setting Adjuster	MC-01	This is the simplest setting adjuster, consisting of a trimmer (1 kΩ) and a dial.	18
	MC-02	Consisting of a centre-tapped trimmer (1 kΩ -1 kΩ) and a dial, this setting adjuster is ideal for a servo system.	18
6-point Setting Adjuster	AMC-V6-S-*-10	Six trimmers are incorporated, so it is possible to set six points.	19
Multifunction Slope Controller	AMC-T-20	This multifunction slope controller generates any desired 2-channel analog voltage pattern outputs. It can also be used with slope-proportional and time-proportional systems.	20

■ Instructions for Power Amplifiers

- The power amplifiers should be kept away from hot and humid conditions which may deteriorate some components of the power amplifiers. They also should be installed in the clean and dry place where the vibration is minimal. Please avoid to install the power amplifiers in the complete enclosure or get them enclosed totally as they need to radiate the heat from semiconductors or ICs inside.
- Please use shielded wires for input signal transmission to prevent the amplifiers from any interference such as noise from outside.

These power amplifiers are used to drive the 10Ω series proportional electro-hydraulic pressure and flow control valves.



Model Number Designation

AME	-D	-10	-100	-20
Series Number	Type of Function	Coil Resistance of Valve	Power Supply	Design Number
AME	D: DC Input Type	10: 10 Ω	100: 100 V AC 200: 200 V AC	20

SK1022	-A	-100	-11
Series Number	Type of Function	Power Supply	Design Number
SK1022: DC Input-Feedback Type	A: Polarity of Feedback Voltage...(-) B: Polarity of Feedback Voltage...(+)	100: 100 V AC 200: 200/220 V AC	11
SK1015: DC Input Type for DC Power Supply	—	—*	11

* Use with 24 V DC since this is for a battery power supply.

Applicable to Valve

Name of Valve	Model Numbers
Pilot Relief Valves	EDG-01*
Relief Valves	EBG-03 EBG-06 EBG-10
Reducing and Relieving Valves	ERBG-06 ERBG-10
10Ω Series Flow Control Valves	EFG 03 EFCG 06
10Ω-10Ω Series High Flow Series Flow Control and Relief Valves	EFBG-03 EFBG-06 EFBG-10

Specifications

Model No.	AME-D-10-*-20	SK1022-A-*-11	SK1022-B-*-11	SK1015-11
Description	AME-D-10-*-20	SK1022-A-*-11	SK1022-B-*-11	SK1015-11
Type of Function	DC Input Type	DC Input Feedback Type	DC Input Feedback Type	DC Input Type
Max. Output Current	1 A (10Ω Solenoid)	1 A (10Ω Solenoid)	1 A (10Ω Solenoid)	0.9 A (10Ω Solenoid)
Max. Input Voltage	+ 10 V DC	+ 10 V DC	+ 10 V DC	+ 10 V DC
Feedback Voltage	—	0 to -10V	0 to +10V	—
Input Impedance	10 kΩ	50 kΩ	50 kΩ	50 kΩ
Max. Gain	1 A / 5 V	1 A / 0.5 V	1 A / 0.5 V	0.9 A / 5 V
Dither	Variable	Fix	Fix	Fix
Temperature Drift (Max.)	0.2 mA /°C	0.2 mA /°C	0.2 mA /°C	1 mA /°C
Power Supply	100 V AC, 200 V AC (50/60 Hz)*	100 V AC, 200/220 V AC ±10% (50/60 Hz)		22-30 V DC
Power Input (Max.)	55 VA	45 VA	45 VA	25 VA
Ambient Temperature	0-50°C (32-122°F)	0-50°C (32-122°F)	0-50°C (32-122°F)	0-50°C (32-122°F)
External Setting Resistance	1 kΩ	1 kΩ	1 kΩ	10 kΩ
Approx. Mass	2.1 kg (4.6 lbs.)	4.5 kg (9.9 lbs.)	4.5 kg (9.9 lbs.)	0.4 kg (.88 lbs.)

* Serviceable Range; 100 V AC can be used from 90 to 132 V AC, 200 V AC can be used from 180 to 264 V AC.

Instructions

Power supply for the setting adjuster can be provided from this power amplifier, but for only one. However, please use the variable resistor or potentiometre of which impedance is 1 kΩ (in case of model SK1015, use 10 kΩ) for the setting adjuster.



AME-D-10-*-20

[Example Diagram]

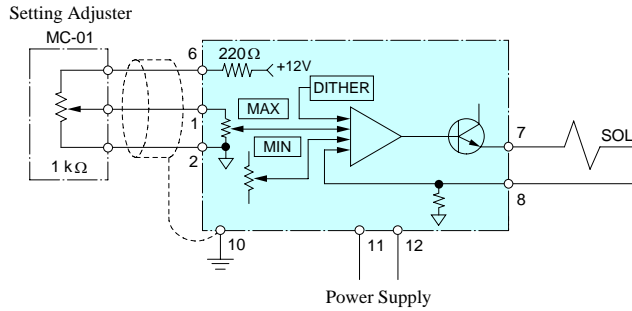

● Terminal Board

Terminal Number	Name
1	Input Signal IN
2	Input Signal COM
3	—
4	—
5	Input Signal COM
6	Internal Power Supply (10 V at 1 kΩ) +12 V
7	Output to Valve SOL
8	Solenoid SOL
9	—
10	Ground G
11	Power Supply
12	100/200 V AC

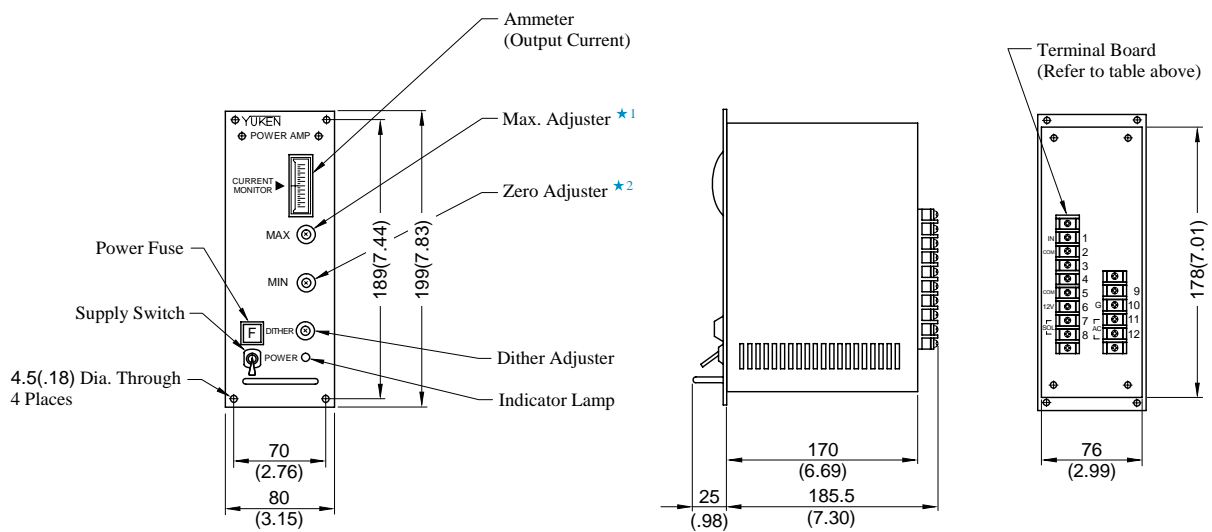

- ★1. Adjustment of upper limit of usable range
- ★2. Adjustment of lower limit of usable range

DIMENSIONS IN
MILLIMETRES (INCHES)

SK1022-A
B-* -11

[Example Diagram]

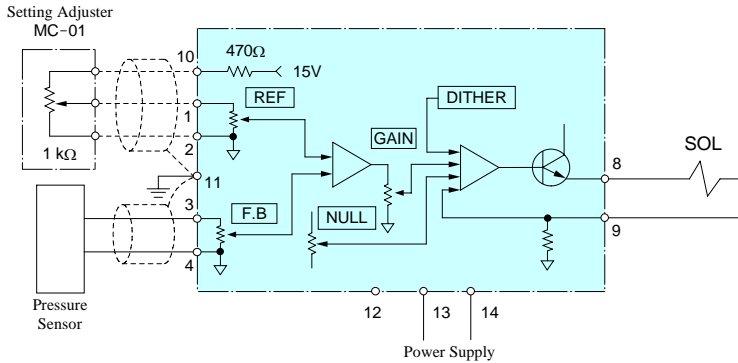

● Terminal Board

Terminal Number	Name	
1	Input Signal REF	
2	Input Signal COM	
3	Feedback Signal F.B	
4	Feedback Signal COM	
5	—	
6	—	
7	—	
8	Output to Valve SOL	
9	Solenoid SOL	
10	Power Supply for Setting Adjuster (10 V at 1 kΩ) +15V	
11	Ground G	
12	Power Supply	
13		100 V AC, 200V AC : 13, 14
14		220 V AC : 12, 14

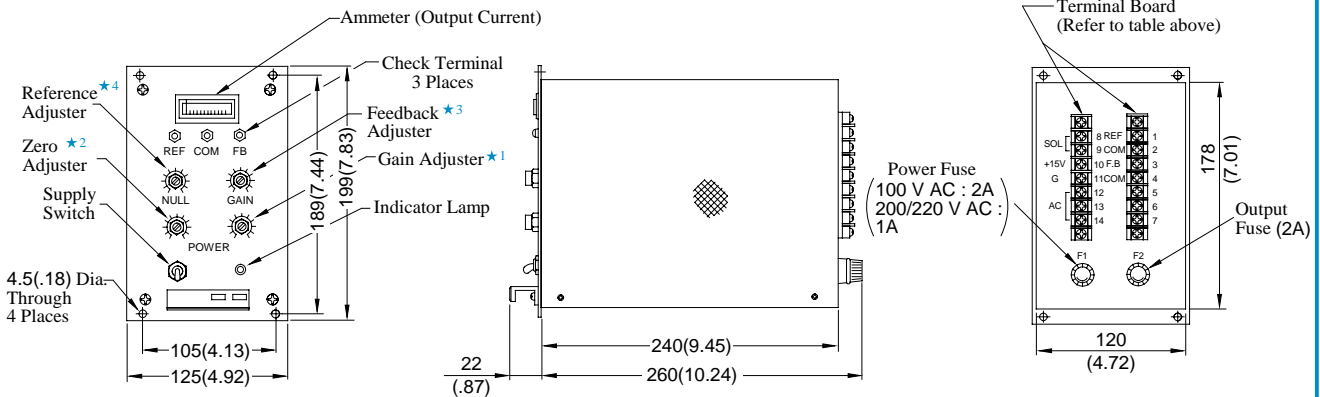

- ★1. Adjustment of upper limit of usable range
- ★2. Adjustment of lower limit of usable range
- ★3. Adjustment of feedback voltage ratio
- ★4. Adjustment of input voltage ratio

DIMENSIONS IN
MILLIMETRES (INCHES)

SK1015-11

[Example Diagram]

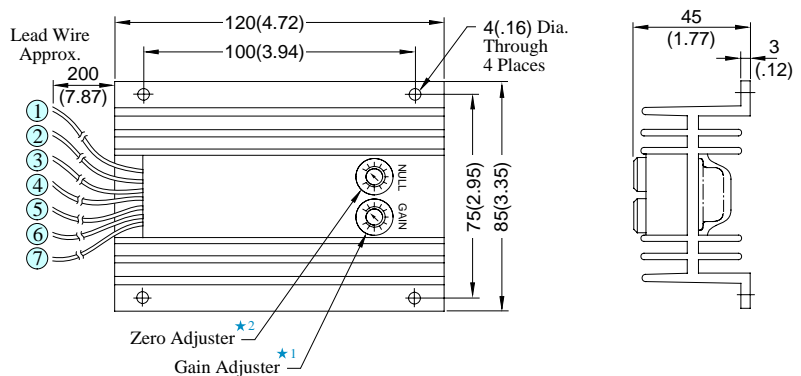
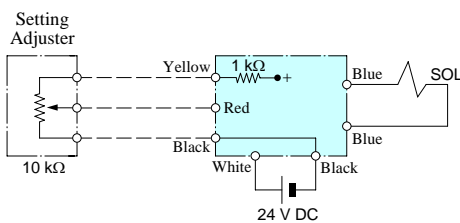

● Lead Wire Detail

- ① White.....Plus of 24 V DC
- ② Black.....Zero of 24 V DC
- ③ Blue.....
- ④ Blue.....} Output to Valve Solenoid
- ⑤ Yellow.....15 V Power Supply for Setting Adjuster (10 V at 10 kΩ)
- ⑥ Red.....Input Signal
- ⑦ Black.....Zero of Input Signal

- ★1. Adjustment of upper limit of usable range
- ★2. Adjustment of lower limit of usable range

Compact power amplifiers for 10Ω proportional solenoids. The power supply is 24 V DC. It uses a new circuitry to be slow to heat.



Model Number Designation

AMN	-D	-10
Series Number	Type of Function	Design Number
AMN	D : DC Input Type	10

Specifications

Description	Model No.	AMN-D-10
Type of Function		DC Input Type
Max. Output Current		1 A (10Ω Solenoid)
Power Input (Max.)		+ 10 V DC
Input Impedance		10 kΩ
Max. Gain		1 A / 5 V
Dither		Variable
Temperature Drift (Max.)		0.2 mA / °C
Power Supply		24 V DC (20 - 30 V DC)
Max. Input Power		25 W
Ambient Temperature		0 - 50°C (32 - 122°F)
External Setting Resistance		1 kΩ
Approx. Mass		0.2 kg (.44 lbs.)

Applicable to Valve

Name of Valve	Model Numbers
Pilot Relief Valves	EDG-01*
Relief Valves	EBG-03 EBG-06 EBG-10
Reducing and Relieving Valves	ERBG-06 ERBG-10
10Ω Series Flow Control Valves	EFG - 03 EFCG - 06
10Ω-10Ω Series High Flow Series Flow Control and Relief Valves	EFBG-03 EFBG-06 EFBG-10

AMN-D-10

[Example Diagram]

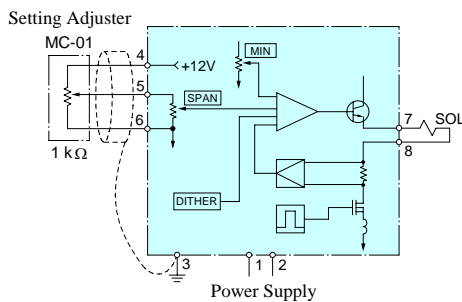

Terminal Board

Terminal Number	Name	
1	Power Supply	+24 V
2	Power Supply	0 V
3	Ground	G
4	Internal Power Supply	+12 V
5	Input Signal	IN
6	Input Signal	COM
7	Output to Valve	SOL
8	Solenoid	

DIMENSIONS IN MILLIMETRES (INCHES)

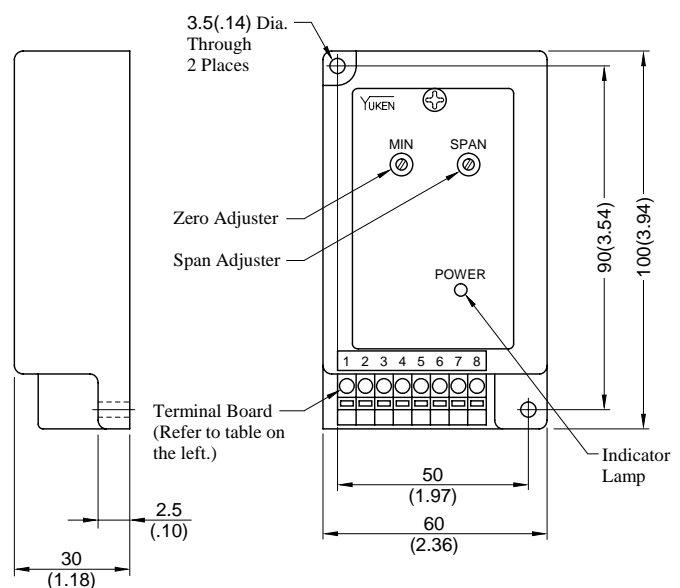

These power amplifiers are used to drive the 40Ω series proportional electro-hydraulic flow control valves.



■ Model Number Designation

AME	-D	-S	-100	-32
Series Number	Type of Function	Type of Mounting	Power Supply	Design Number
AME	D: DC Input Type	S: Panel Mounting Type	100: 100 V AC 200: 200/220 V AC	32
	DF: DC Input Feedback Type			22
	T: Slow Up Down Type			22

■ Applicable to Valve

Name of Valve	Model Numbers
40Ω Series Flow Control Valve	EFG EFCG -02/03/06/10
40Ω-10Ω Series Flow Control and Relief Valve	EFBG-03/06/10

■ Specifications

Model No.	AME-D-S-*-32	AME-DF-S-*-22	AME-T-S-*-22
Description			
Type of Function	DC Input Type	DC Input Feedback Type	Slow Up Down Type
Max. Output Current	0.8 A (40Ω Solenoid)	0.8 A (40Ω Solenoid)	0.8 A (40Ω Solenoid)
Max. Input Voltage	+ 10 V DC	+ 10 V DC	—
Feedback Voltage	—	0 to -10 V	—
Input Impedance	10 kΩ	50 kΩ	—
Slow Up Down Range	—	—	0.05 to 1 s / 100 mA
Max. Gain	0.8 A / 5 V	0.8 A / 5 V	—
Dither	Fix	Fix	Fix
Temperature Drift (Max.)	0.2 mA / °C	0.2 mA / °C	0.2 mA / °C
Power Supply	100 V AC, 200/220 V AC ±10% (50/60 Hz)		
Power Input (Max.)	90 VA	90 VA	90 VA
Ambient Temperature	0-50°C (32-122°F)	0-50°C (32-122°F)	0-50°C (32-122°F)
External Setting Resistance	1 kΩ	1 kΩ	—
Approx. Mass	4.5 kg (9.9 lbs.)	4.5 kg (9.9 lbs.)	4.5 kg (9.9 lbs.)

■ Instructions

When DC input type (AME-D-S) or DC input-feedback type (AME-DF-S) power amplifier is used, power supply for the setting adjuster can be provided from this power amplifier, but for only one. However, please use the variable resistor or potentiometre of which impedance is 1 kΩ for the setting adjuster.

AME-D-S-※-32

[Example Diagram]

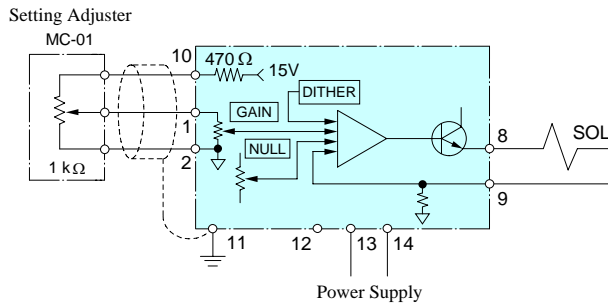

● Terminal Board

Terminal Number	Name
1	Input Signal IN
2	Input Signal COM
3	—
4	—
5	—
6	—
7	—
8	—
9	Output to Valve Solenoid SOL
10	Power Supply for Setting Adjuster (10 V at 1 kΩ) +15 V
11	Ground G
12	Power Supply 100 V AC, 200 V AC: 13, 14 220 V AC: 12, 14
13	
14	

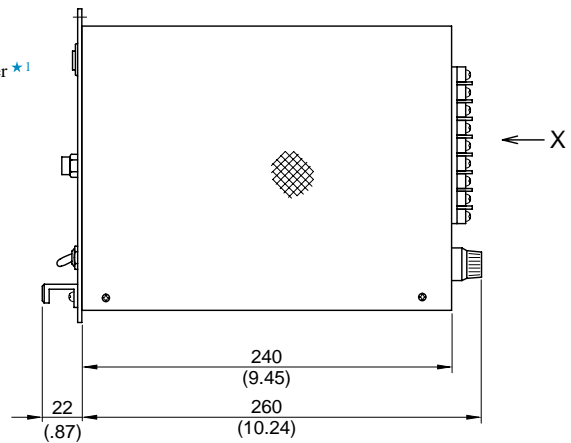
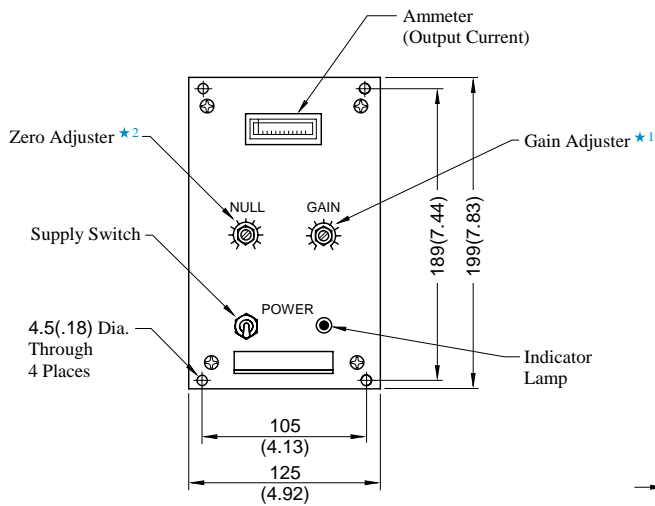

- ★1. Adjustment of upper limit of usable range
- ★2. Adjustment of lower limit of usable range

**DIMENSIONS IN
MILLIMETRES (INCHES)**

(Power Fuse
100 V AC: 3 A
200/220 V AC: 1.5 A)

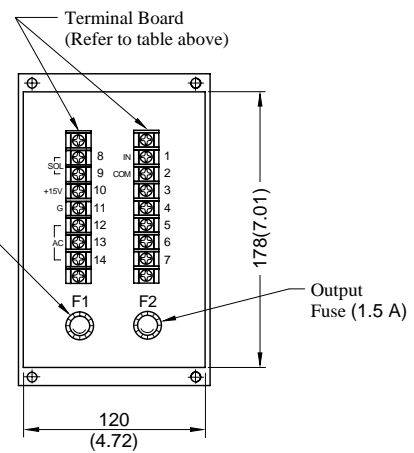

View Arrow X

AME-DF-S-* -22

[Example Diagram]

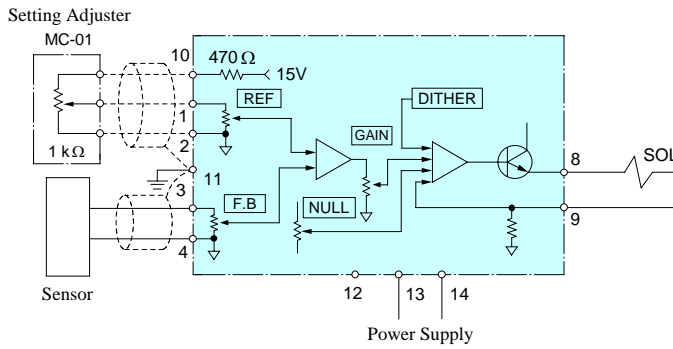

● Terminal Board

Terminal Number	Name
1	Input Signal IN
2	Input Signal COM
3	Feedback Signal F.B
4	Feedback Signal COM
5	—
6	—
7	—
8	Output to Valve Solenoid SOL
9	
10	Power Supply for Setting Adjuster (10 V at 1 kΩ) +15 V
11	Ground G
12	Power Supply 100 V AC, 200 V AC: 13, 14 220 V AC: 12, 14
13	
14	

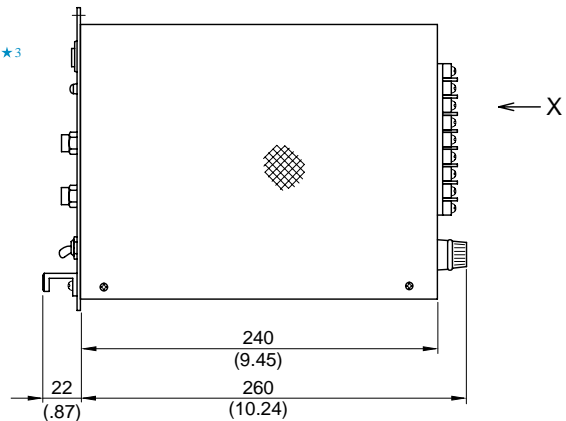
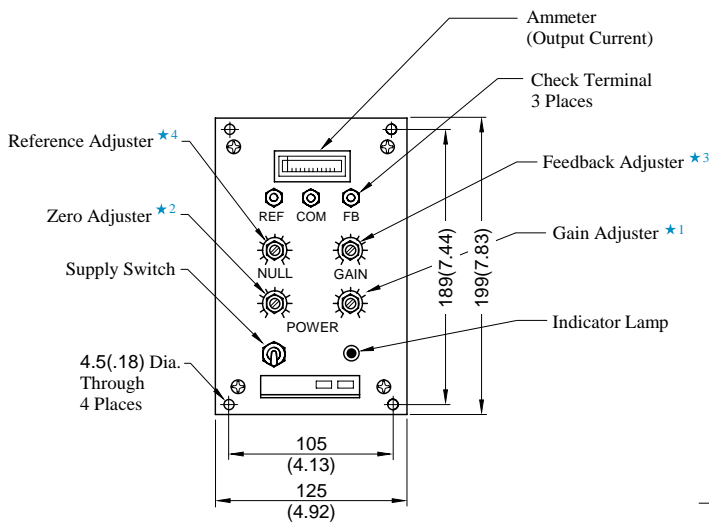

- ★1. Adjustment of upper limit of usable range
- ★2. Adjustment of lower limit of usable range
- ★3. Adjustment of feedback voltage ratio
- ★4. Adjustment of input voltage ratio

**DIMENSIONS IN
MILLIMETRES (INCHES)**

(Power Fuse
100 V AC: 3 A
200/220 V AC: 1.5 A)

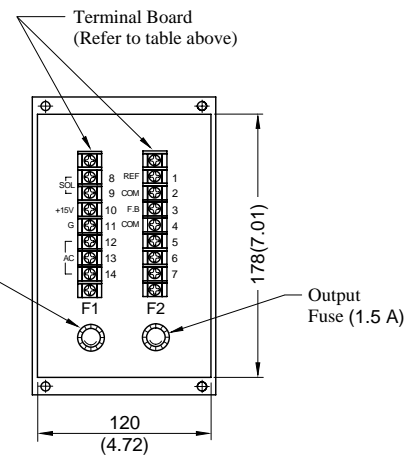

View Arrow X



AME-T-S-* -22

● Terminal Board

[Example Diagram]

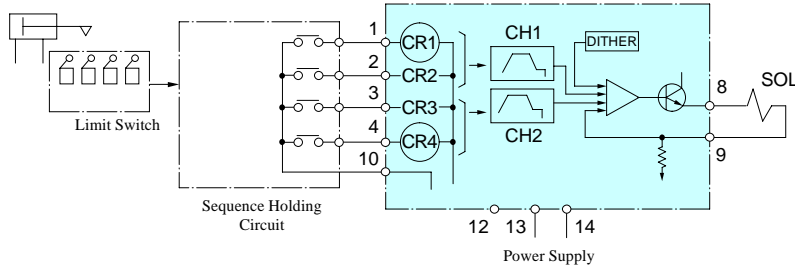

Terminal Number	Name	
1	Input Command CR1	
2	Input Command CR2	
3	Input Command CR3	
4	Input Command CR4	
5	—	
6	—	
7	—	
8	Output to Valve Solenoid SOL	
9		
10	Input Command CR.COM	
11	Ground G	
12	Power Supply	
13		100 V AC, 200 V AC: 13, 14
14		

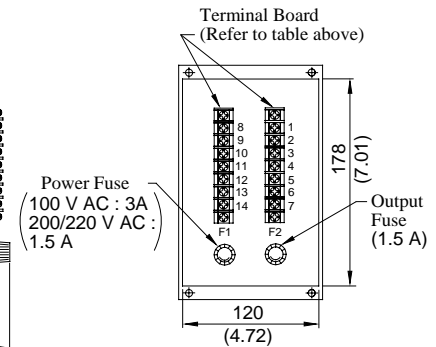
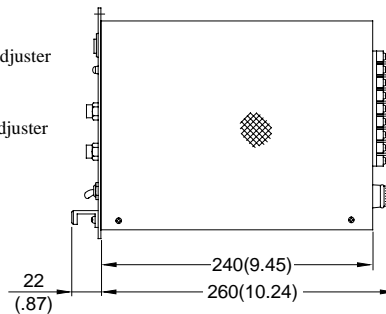
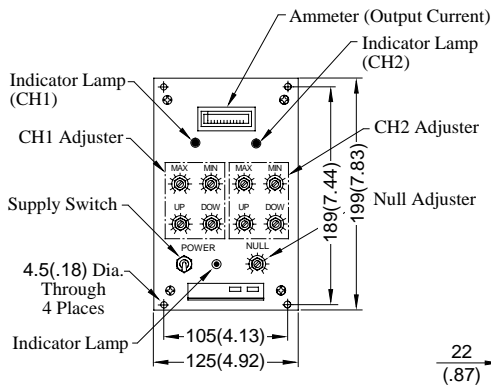

[Output Current Pattern]

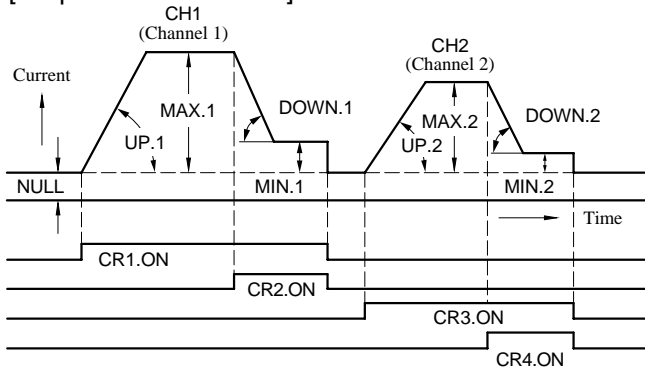

**DIMENSIONS IN
MILLIMETRES (INCHES)**

Terminal
1 & 10 in Short-Circuit
2 & 10 in Short-Circuit
3 & 10 in Short-Circuit
4 & 10 in Short-Circuit

Note: 1. CR1 to CR4: Relays in the power amplifier.

The output patterns CH1 and CH2 can not be obtained simultaneously nor can they be transmitted halfway to another pattern.

2. The words such as MAX, MIN, UP and DOWN show the volume adjustment of the power amplifier.

■ **How to Calculate Accelerating and Decelerating Time (Example)**

Question: Wish to accelerate and decelerate the actuator in between 5 L/min (1.32 U.S. GPM) and 25 L/min (6.6 U.S. GPM) in the use of proportional flow control valve model EFG-02-30. In such case, what are the maximum and minimum time adjustable for the acceleration and deceleration?

Answer: The input current for EFG-02-30 at the flow rate of 5 L/min (1.32 U.S.GPM) and 25 L/min (6.6 U.S. GPM) can be obtained respectively from the chart below. The chart shows:

Input current at 5 L/min (1.32 U.S. GPM) 300 mA
 Input current at 25 L/min (6.6 U.S. GPM) 520 mA

Then, the difference between the above two can be obtained with the following formula:
 520 mA-300 mA=220 mA

While, the specification for the model AME-T-S shows the amplifier's gradient for acceleration or deceleration as being between 0.05 s/100 mA and 1.0 s/100 mA (which means that the minimum time is 0.05 second and the maximum time is 1.0 second for every 100 mA variation). Therefore, the minimum and maximum adjustable time can be obtained as follows:

$$\frac{220 \text{ mA}}{100 \text{ mA}} \times 0.05 \text{ second} = 0.11 \text{ second (Minimum)}$$

$$\frac{220 \text{ mA}}{100 \text{ mA}} \times 1.0 \text{ second} = 2.2 \text{ second (Maximum)}$$

The result above are as illustrated on the below.

[Flow Pattern]

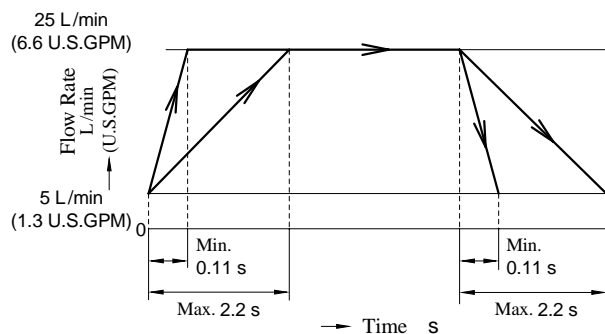

[Input Current vs. Flow]

EFG-02

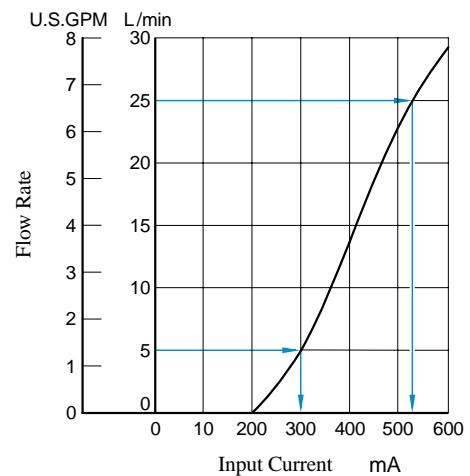

These power amplifiers are specially designed to combine and incorporate the functions of pressure control (10 Ω solenoid) and flow control (40 Ω solenoid) into one and can be used for the proportional electro-hydraulic flow control and relief valves of which model numbers are as shown below.



Model Number Designation

AME	-D2	-H1	-100	-12
Series Number	Type of Function	Type of Mounting	Power Supply	Design Number
AME	D2 : DC Input Type	H1 : Wall Tapestry Type	100 : 100 V AC 200 : 200/220 V AC	12

Applicable to Valve

Name of Valve	Model Numbers
40Ω- 10Ω Series Flow Control and Relief Valve	03-125 EFBG-06-250 ^C _H 10-500

Specifications

Description	AME-D2-H1-*-12	
	Flow Controls (40Ω Solenoid)	Pressure Controls (10Ω Solenoid)
Type of Function	DC Input Type	DC Input Type
Max. Output Current	0.8 A (40Ω Solenoid)	1 A (10Ω Solenoid)
Max. Input Voltage	+10 V DC	+10 V DC
Input Impedance	10 kΩ	10 kΩ
Max. Gain	0.8 A / 5 V	1 A / 5 V
Dither	Fix	Fix
Temperature Drift (Max.)	0.2 mA /°C	0.2 mA /°C
Power Supply	100 V AC, 200/220 V AC ± 10% (50/60 Hz)	
Power Input (Max.)	130 VA	
Ambient Temperature	0-50°C (32-122°F)	
External Setting Resistance	1 kΩ	1 kΩ
Approx. Mass	5.6 kg (12.3 lbs.)	

Instructions

Power supply for the setting adjuster up to 2 set can be provided from this power amplifier. However, please use the variable resistor or potentiometre of which impedance is 1 kΩ for the setting adjuster.

AME-D2-H1-*-12

[Example Diagram]

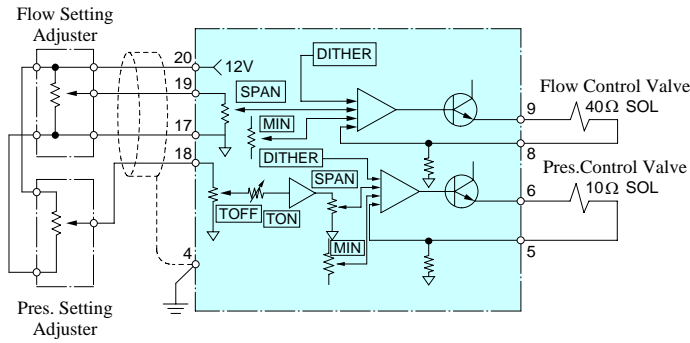

● Terminal Board

Terminal Number	Name
1	Power Supply 100 V AC, 200 V AC: 1, 2 220 V AC: 1, 3
2	
3	
4	Ground G
5	Output to Pressure Control
6	Valve (10Ω) Solenoid PR. SOL
7	Ammeter
8	Output to Flow Control
9	Valve (40Ω) Solenoid FL. SOL
10	Ammeter
11	Common COM
12	—
13	—
14	-12 V OUT -12 V
15	Common COM
16	+12 V OUT +12 V
17	Common COM
18	Input Signal for PRES. PR.IN
19	Input Signal for FLOW FL.IN
20	+12 V OUT +12 V

Terminal Board
(Refer to the table
on the right above.)

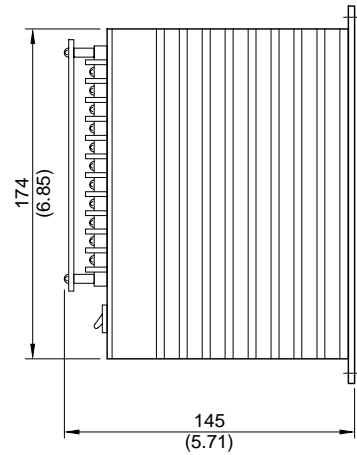
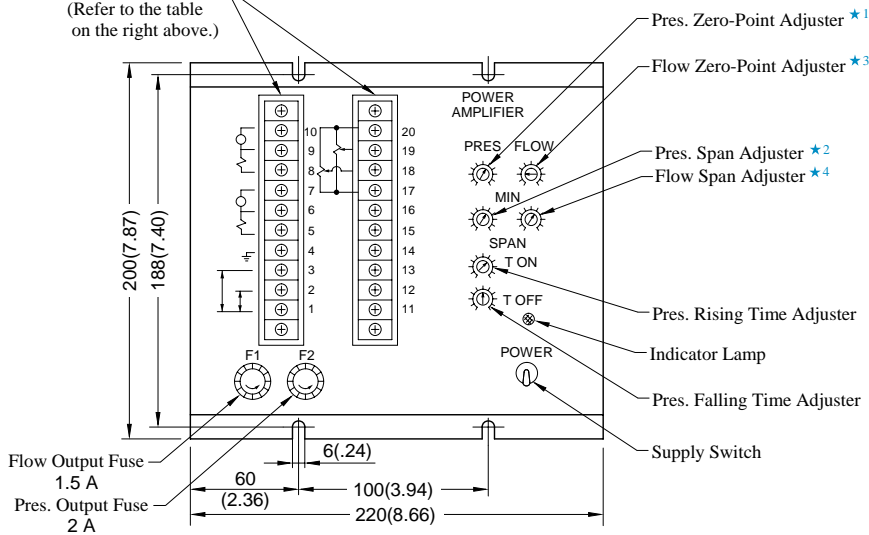

- ★ 1. Minimum Pressure Setting
- ★ 2. Variable Pressure Range Setting
- ★ 3. Minimum Flow Setting
- ★ 4. Variable Flow Range Setting

DIMENSIONS IN
MILLIMETRES (INCHES)



These power amplifiers can drive two solenoid of 10Ω load simultaneously or separately, and the control can be done in the same way even though the object is separated by pressure system and flow rate system. Although the display of control unit on the front panel is **PRESS** and **FLOW**, they are exactly the same circuit, so there is no distinction between the two system when used.



Model Number Designation

AME	-D2	-1010	-100	-10
Series Number	Type of Function	Coil Resistance of Valve	Power Supply	Design Number
AME	D2: DC Input Type	1010: 10 Ω × 2	100: 100 V AC 200: 200/220 V AC	10

Applicable to Valve

Name of Valve	Model Numbers
Pilot Relief Valves	EDG-01*
Relief Valves	EBG-03 EBG-06 EBG-10
Reducing and Relieving Valves	ERBG-06 ERBG-10
10Ω Series Flow Control Valves	EFG 03 EFCG 06
10Ω-10Ω Series High Flow Series Flow Control and Relief Valves	EFBG-03 EFBG-06 EFBG-10

Specifications

Model No.	AME-D2-1010-*-10
Description	
Type of Function	DC Input Type
Max. Output Current	1 A (10Ω Solenoid)
Max. Input Voltage	+ 10 V DC
Input Impedance	10 kΩ
Max. Gain	1 A / 5 V
Dither	Variable 100-300 mA
Temperature Drift (Max.)	0.2 mA / °C
Power Supply	100 V AC, 200/220 V AC ±10% (50/60 Hz)
Power Input (Max.)	120 VA
Ambient Temperature	0-50°C (32-122°F)
External Setting Resistance	1 kΩ
Approx. Mass	4.3 kg (9.5 lbs.)

Applicable to Piston Pump

Name of Pump	Model Numbers
"A" Series Variable Displacement Piston Pump	A16
	A22
	A37 *-R-04
	A56
	A70
Proportional Electro-Hydraulic Load Sensing Type	A90 *-R-04
	A145
	Also, double pumps combined with the models listed above and fixed displacement vane pumps.

Instructions

Power supply for the setting adjuster up to 2 set can be provided from this power amplifier. However, please use the variable resistor or potentiometer of which impedance is 1 kΩ for the setting adjuster.

AME-D2-1010-*-10

[Example Diagram]

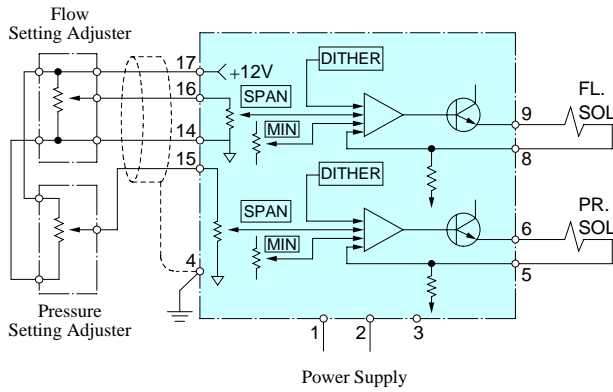

● Terminal Board

Terminal Number	Name
1	Power Supply 100 V AC, 200 V AC: 1, 2 220 V AC: 1, 3
2	
3	
4	Ground G
5	Output to Pressure Control
6	Valve Solenoid PR.SOL
7	Ammeter
8	Output to Flow Control
9	Valve Solenoid FL.SOL
10	Ammeter
11	-12 V OUT -12 V
12	Common COM
13	+12V OUT +12 V
14	Common COM
15	Input Signal for PRES. PR. IN
16	Input Signal for FLOW FL. IN
17	+12V OUT +12 V

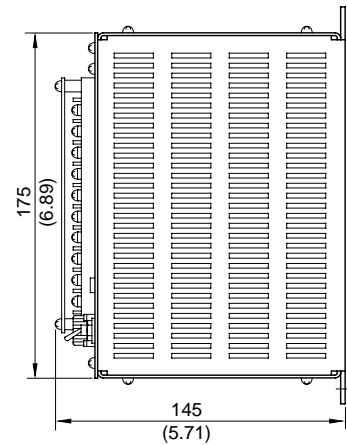
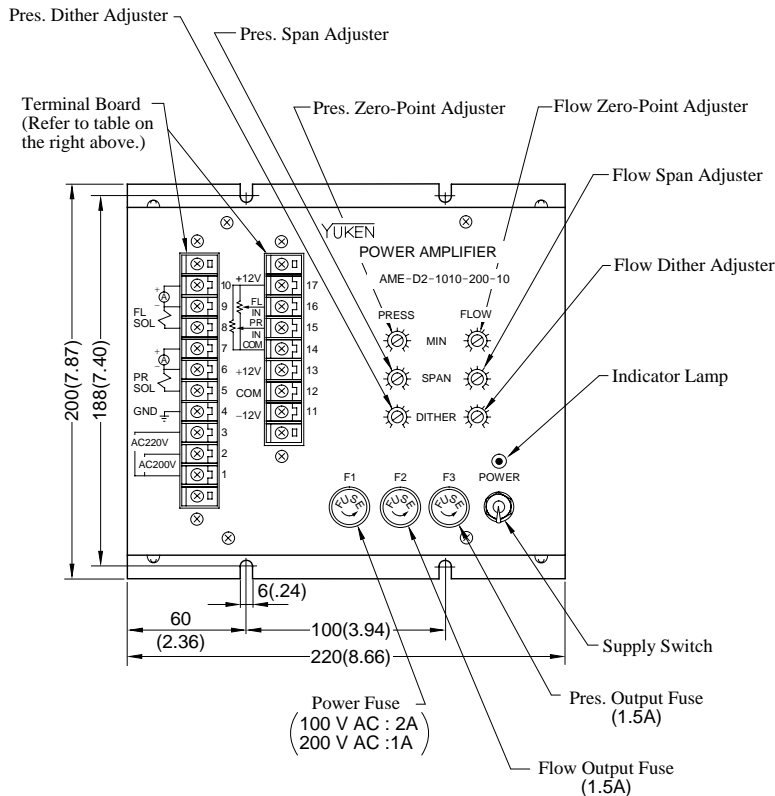

DIMENSIONS IN
MILLIMETRES (INCHES)



■ Model Number Designation

SK1091	-D24	-10
Series Number	Power Supply	Design Number
SK1091	D24: 24 V DC	10

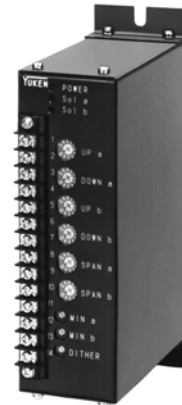

■ Applicable to Valve

Name of Valve	Model Numbers
Directional and Flow Control Valve	03 EDFHG-04 06

■ Specifications

Model No.	SK1091-D24-10
Description	
Max. Output Current	1 A (10Ω Solenoid)
Max. Input Voltage	-10 V DC for SOL a +10 V DC for SOL b
Input Impedance	10 kΩ
Max. Gain	1 A / ±5 V
Dither	Variable
Delay Time Adjustment Range	0.15-3 s
Temperature Drift (Max.)	0.2 mA /°C
Power Supply	24 V DC (21-28 V Included Ripple)
Required Current	More than 1.5 A
Power Input (Max.)	25 W
Ambient Temperature	0-50°C (32-122°F)
Ambient Humidity	Less than 90%RH
External Setting Resistance	2 kΩ
Approx. Mass	1.0 kg (2.2 lbs.)

■ Instructions

● Power Supply for the Setting Adjuster

Power supply for the setting adjuster can be provided from this power amplifier, but for only one. However, please use the variable resistor or potentiometre of which impedance is 2 kΩ for the setting adjuster.

● Power Switch

The power amplifier has no power supply switch. As soon as it is connected to a power supply, it comes to be alive. Provide a power switch externally.

SK1091-D24-10

[Example Diagram]

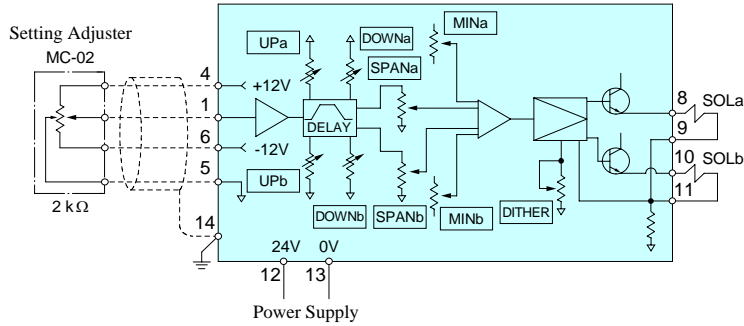

[Input-Output Characteristics]

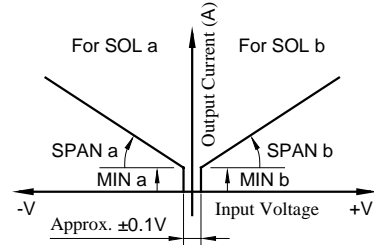

● Terminal Board

Terminal Number	Name
1	Input Signal IN
2	Input Signal COM
3	—
4	Power Supply for Setting Adjuster +12V
5	Power Supply for Setting Adjuster COM
6	Power Supply for Setting Adjuster -12V
7	—
8	Output to Valve Solenoid SOL a
9	Output to Valve Solenoid SOL b
10	Output to Valve Solenoid SOL b
11	Output to Valve Solenoid SOL b
12	Power Supply 24 V
13	Power Supply 0 V
14	Ground FG

[Delay Function]

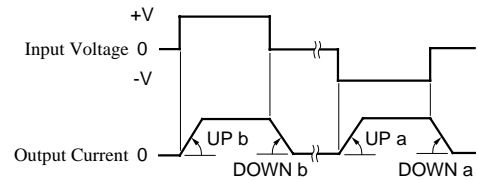

DIMENSIONS IN
MILLIMETRES (INCHES)

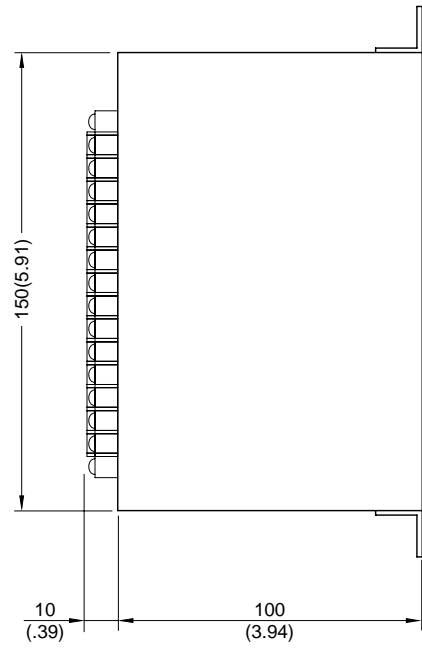
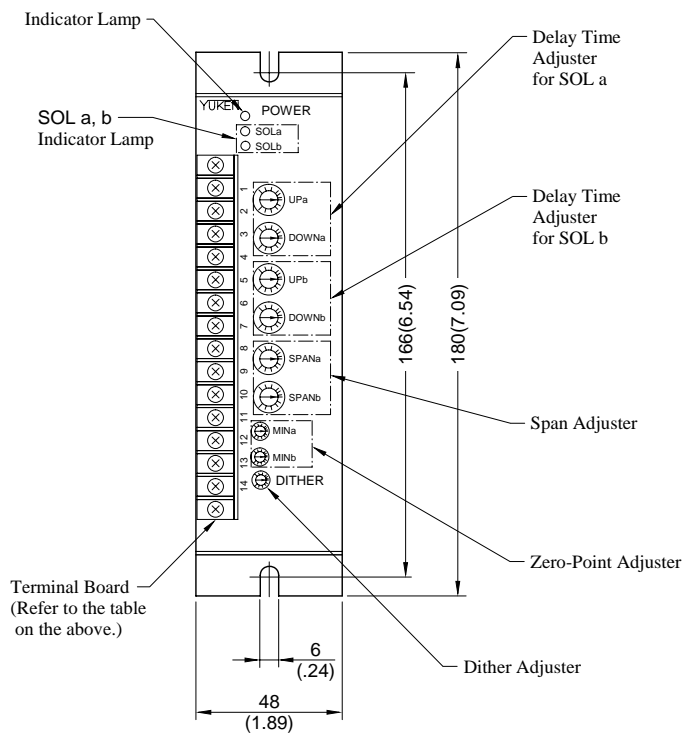

MC-01

[Electric Circuit]

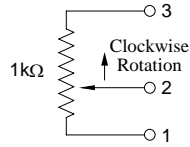

[Example Diagram]

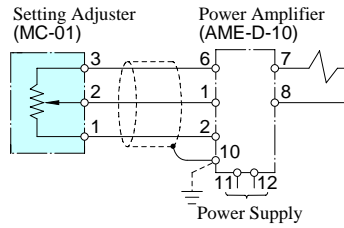

[Mounting Panel]

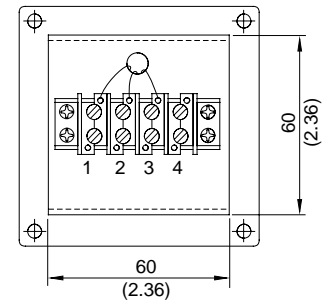
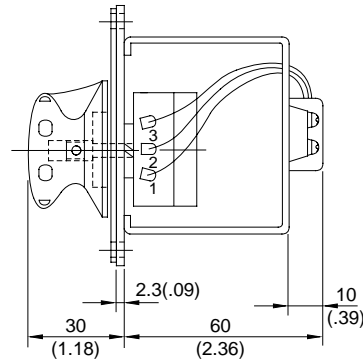
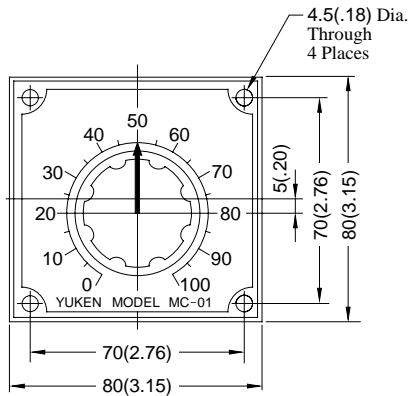
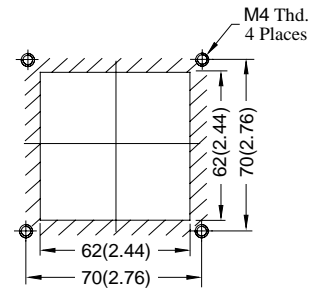

DIMENSIONS IN
MILLIMETRES (INCHES)

MC-02

[How to Use]

This setting adjuster is for using positive and negative voltages to the right and left of the zero point. Most suitable for servo systems. Please contact us for usage details.

[Electric Circuit]

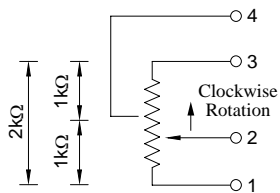

[Example Diagram]

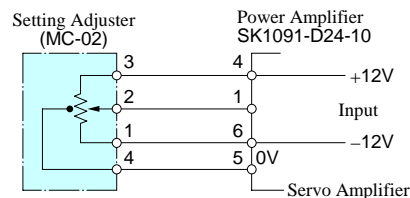

[Mounting Panel]

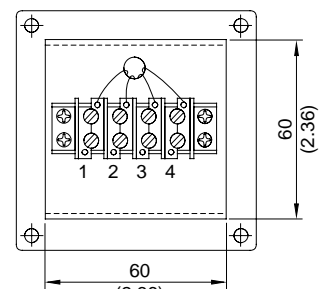
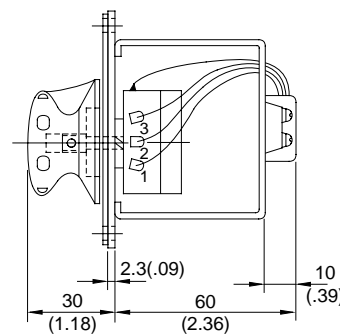
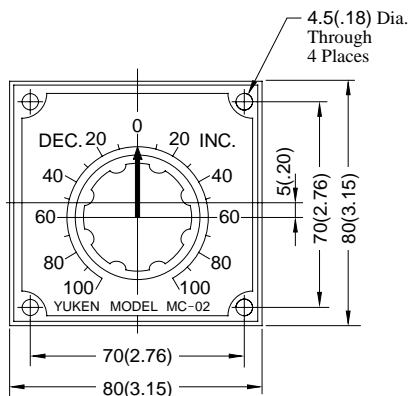
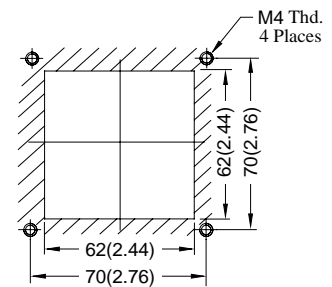

AMC-V6-S-*-10

Power Supply
 100.....100 V AC
 200.....200 V AC
 220.....220 V AC

[Electric Circuit]

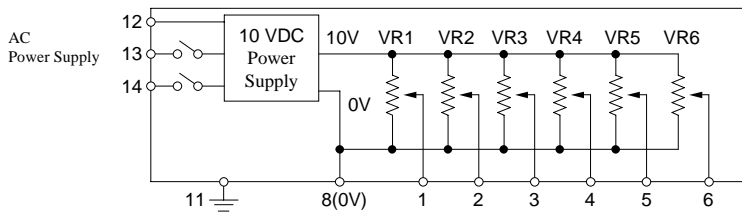

[Example Diagram]

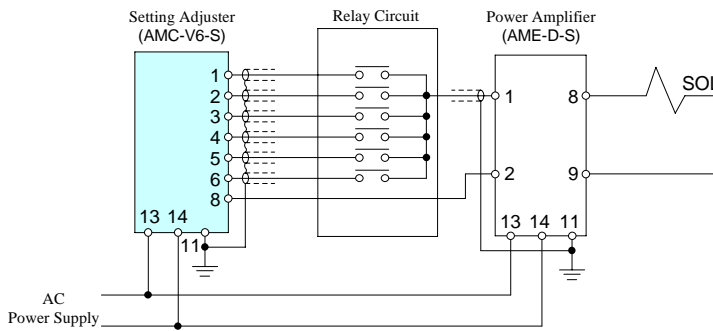

Terminal Board

Terminal Number	Name
1	1 OUT (VR1)
2	2 OUT (VR2)
3	3 OUT (VR3)
4	4 OUT (VR4)
5	5 OUT (VR5)
6	6 OUT (VR6)
7	—
8	0V COM
9	—
10	—
11	Ground G
12	—
13	Power Supply
14	85-265 V AC

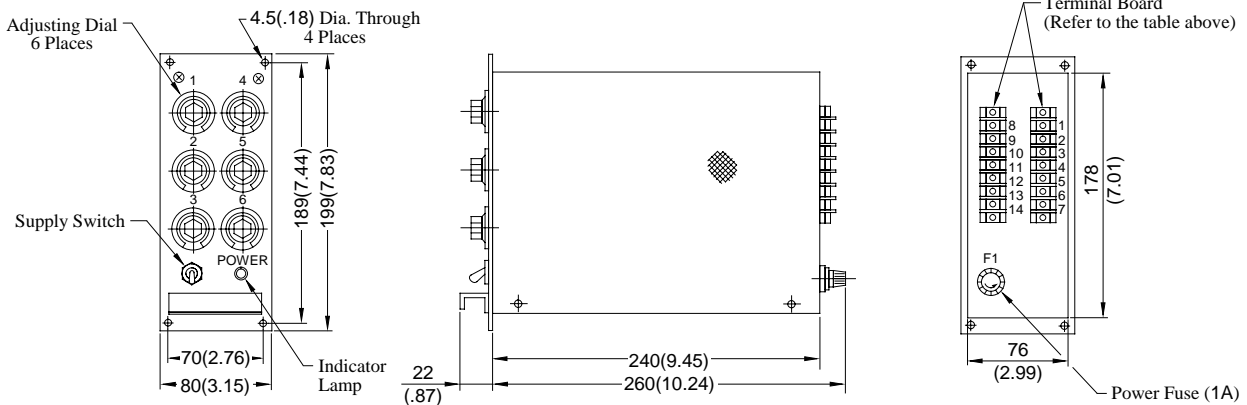

**DIMENSIONS IN
MILLIMETRES (INCHES)**



This controller can generate any desired 2-channel analog voltage pattern outputs and can be used with slope-proportional and time-proportional systems.



Model Number Designation

AMC	-T	-20
Series Number	Type of Function	Design Number
AMC : Setting Adjuster	T : Acceleration/deceleration signal type (Slope Controller)	20

Specifications

Model No.	AMC-T-20				
Description					
Number of Output Channels	2 channels (A, B)				
Maximum Output Range	0 - +5 V★, 0 - ±5 V, 0 - +10 V, 0 - ±10 V (The settings are DIP switch selectable)				
Two Categories of Slopes	<table style="width: 100%; border-collapse: collapse;"> <tr> <td style="width: 50%; border-right: 1px solid black;"> Slope-constant With a level change, the slope will not change (but arrival time changes.) </td> <td rowspan="2" style="font-size: 3em; vertical-align: middle;">}</td> <td rowspan="2" style="vertical-align: middle;">(to be selected by DIP switch)</td> </tr> <tr> <td style="border-right: 1px solid black;"> Time-constant With a level change, the time will not change (but the slope changes.) </td> </tr> </table>	Slope-constant With a level change, the slope will not change (but arrival time changes.)	}	(to be selected by DIP switch)	Time-constant With a level change, the time will not change (but the slope changes.)
Slope-constant With a level change, the slope will not change (but arrival time changes.)	}	(to be selected by DIP switch)			
Time-constant With a level change, the time will not change (but the slope changes.)					
Acceleration/Deceleration Signal Type	4 Types Polygonal Line Signal★ : 1 Type (to be selected by DIP switch) Curve Compensation Signal : 3 Types				
Maximum Slope Time	5 s★, 20 s, 50 s, 100 s (The settings are DIP switch selectable)				
Setting Resolution	The level and slope settings are variable in 0.1% units from 0 to ±99.9%				
Control Mode Number of Preselected Patterns	Mode 1, 4-bit binary code input, 15 patterns Mode 2, 6-bit binary code input, 63 patterns Mode 3, Timer control, 9 patterns (4 variations)				
Stop Mode (Applicable Only for Control Mode 1)	ON : The stop mode is to retain the state of controller output at the instant an external input signal is interrupted. When the external signal is input again, the operation is resumed from the retained state. OFF★ : When external input signal is interrupted, function goes back to the initial setting (Pattern No.0).				
Control Input Signal	Current input type, 10 mA /bit max. Usable as a voltage input type (voltage range: 8 to 48V DC) Photocoupler insulation input				
Control Output Signal	Output from transistor open collector Max. 30V, 50 mA				
Data Save	EEP-ROM (Battery not needed)				
Power Supply	100/200 V AC, 50/60 Hz (85-260 V AC)				
Power Input	Less than 10 VA				
Ambient Temperature	0-50°C (32-122°F)				
Ambient Humidity	Less than 85%RH (Bedewing must be avoided)				
Approx. Mass	1 kg (2.2 lbs.)				

Note: ★ Indicates preset conditions.

Instructions

- Since this controller incorporates a micro computer, do subject it to undue electrical noise.

Control Modes

One among the following 3 types of control modes can be chosen by changing DIP switch.

Control Mode 1

Channels A and B generate optional slopes independently each other.

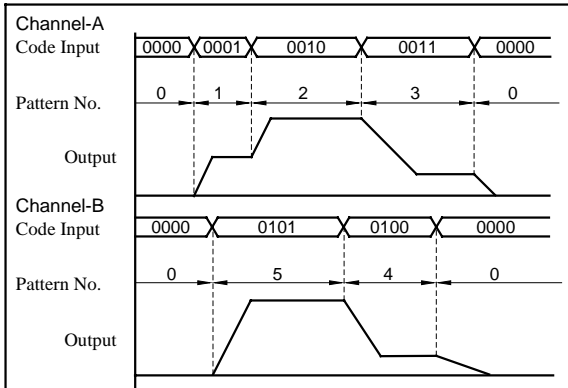

Control Mode 2

A slope is generated by a strobe signal (signal for change to next signal). Channels A and B operate synchronously.

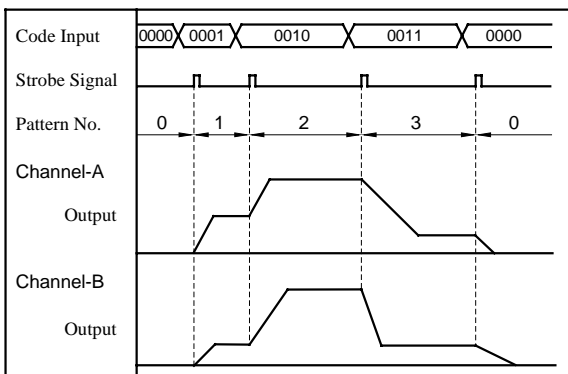

Control Mode 3

The internal timer is activated by a start signal, causing the slopes to be generated successively in memory. Channels A and B operate independently.

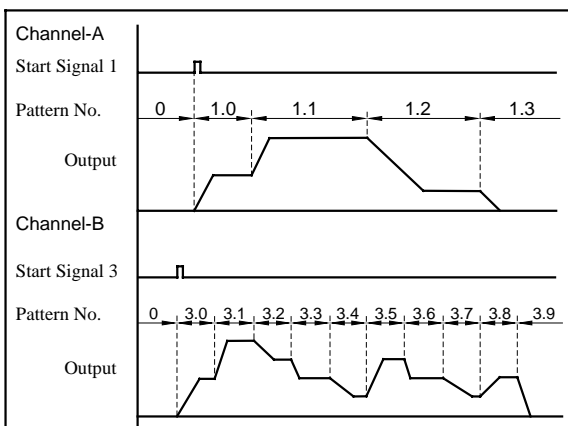

Setting Example

Control Mode 1 A Channel

Code Input				Pattern No.	Setting %		Remarks
A8	A4	A2	A1		Level	Slope	
OFF	OFF	OFF	OFF	0	0	0	Stop
OFF	OFF	OFF	ON	1	99.9	40.0	Cylinder forward acceleration
OFF	OFF	ON	OFF	2	-80.0	60.0	Cylinder backward acceleration
OFF	OFF	ON	ON	3	10.0	50.0	Cylinder forward deceleration
ON	ON	ON	ON	15	10.0	10.0	

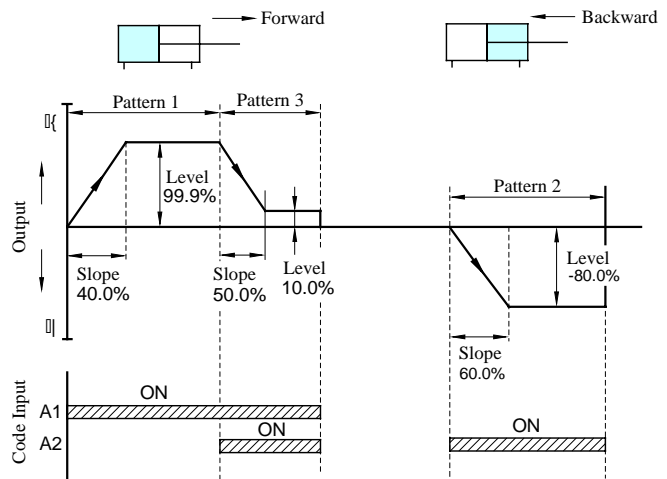

Slope Type

One among the following 4 types can be chosen by changing DIP switch.

Type 1

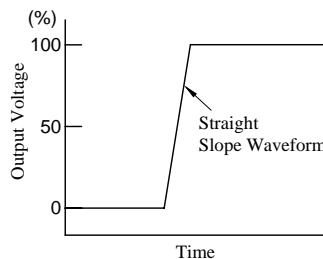

Type 2

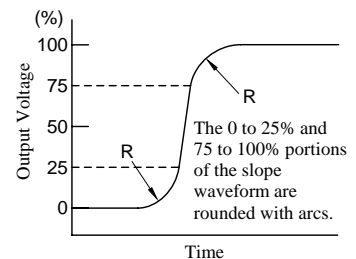

Type 3

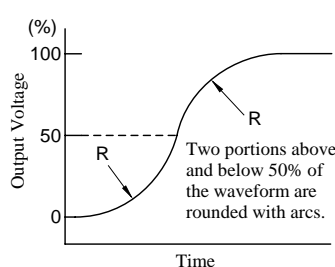

Type 4

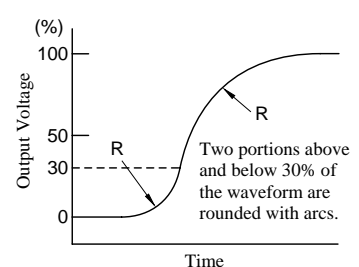

AMC-T

[Example Diagram]

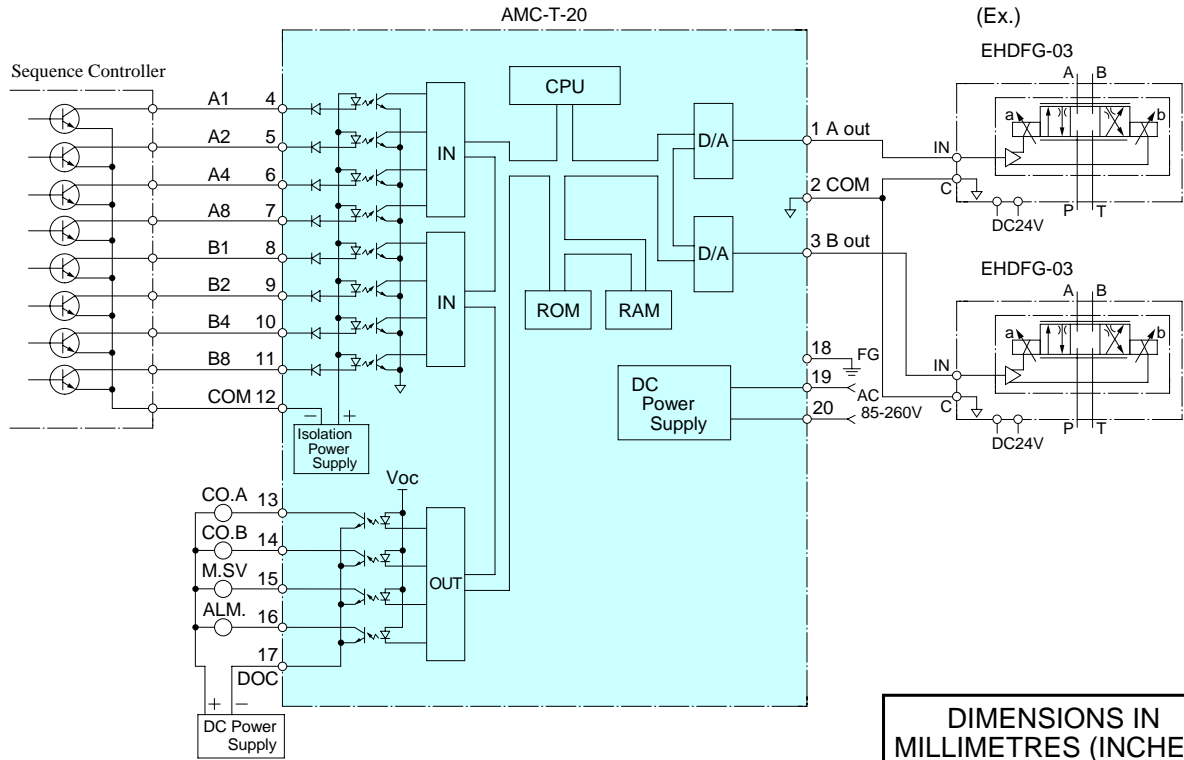

DIMENSIONS IN
MILLIMETRES (INCHES)

Terminal Board

Terminal Number	Name	Terminal Number	Name		
1	Channel A Output	A out	11	Code Input	B8
2	Common	COM	12	Code Input Common	DCOM
3	Channel B Output	B out	13	Coincidental Output Signal with "A"	CO.A
4	Code Input	A1	14	Coincidental Output Signal with "B"	CO.B
5	Code Input	A2	15	Data Save Signal	M.SV
6	Code Input	A4	16	Alarm Signal Output	ALM.
7	Code Input	A8	17	Output Common	DOC
8	Code Input	B1	18	Ground	FG
9	Code Input	B2	19	Power Supply	AC
10	Code Input	B4	20		

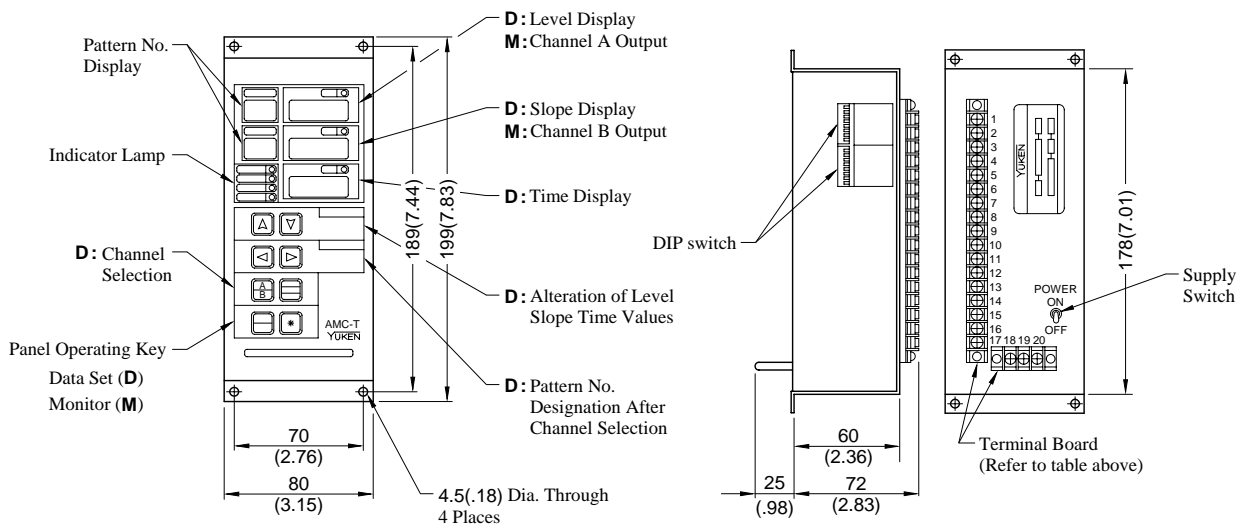

■ Interchangeability between Current and New Design

● Specifications

Specifications unchanged unless specified below.

Description	New : AMC-T-20	Current : AMC-T-10
Control Output Signal	Output from transistor open collector Max. 30 V, 50 mA	Output from transistor open collector Max. 30 V, 10 mA
Slope Types	4 Types Polygonal Line Signal : 1 Type (to be selected by DIP switch) Curve Compensation Signal : 3 Types	1 Type : Polygonal Line Signal
Stop Mode (Applicable only for Control Mode 1)	ON, OFF	—
Data Save	EEP-ROM Battery not needed	Battery Required
Approx. Mass	1 kg (2.2 lbs.)	1.8 kg (4.0 lbs.)

● Terminal

The following are differences between current and new.

Terminal Number	Name		Remarks
	New : Design 20	Current : Design 10	
13	Coincidental Output Signal with "A" "CO.A"	Coincidental Output Signal with "A" "DO1"	Abbreviation of the terminals are changed, though functionally the same.
14	Coincidental Output Signal with "B" "CO.B"	Coincidental Output Signal with "B" "DO2"	
15	Data Save Signal "M.SV"	—	Added new functions.
16	Alarm Signal Output "ALM."	—	

● Interchangeability in Installation

There is an interchangeability in installation, although depths (dimensions "A" and "B") are different.

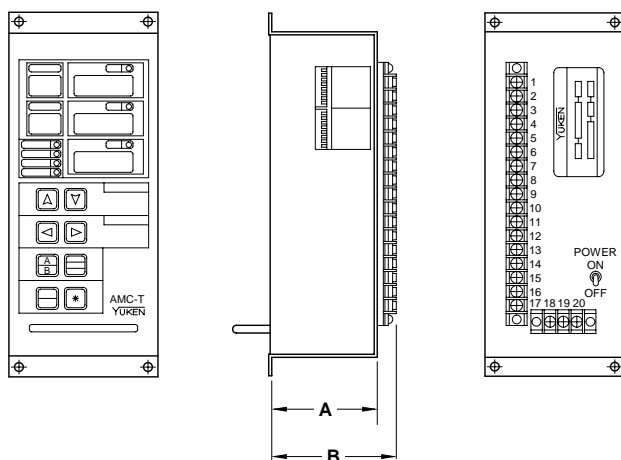

Model Numbers		mm (Inches)	
		A	B
Current	AMC-T-10	185 (7.28)	200 (7.87)
New	AMC-T-20	60 (2.36)	72 (2.83)

