

G

LOGIC VALVES

Valve Type	Maximum Operating Pressure MPa (PSI)	Rated Flow															Catalogue No.
		U.S.GPM: 1, 2, 3, 5, 10, 20, 30, 50, 100, 200, 300, 500, 1000, 3000, 6000 L/min: .5, 1, 2, 5, 10, 20, 30, 50, 100, 200, 300, 500, 1000, 1500															
Directional Control Logic Valves Directional and Flow Control Logic Valves	31.5 (4570)	LD															Pub. EC-1601
Solenoid Operated Directional Control Logic Valves	31.5 (4570)	LDS															
Relief Logic Valves	31.5 (4570)	LB															
Solenoid Controlled Relief Logic Valves	31.5 (4570)	LBS															

YUKEN

**DIRECTIONAL CONTROL (LD)
DIRECTIONAL AND FLOW CONTROL (LD)
SOLENOID OPERATED DIRECTIONAL
CONTROL (LDS)
RELIEF (LB) / SOLENOID CONTROLLED
RELIEF (LBS)**

**LOGIC
VALVES**

Up to 31.5 MPa (4570 PSI), 5500 L / min (1453 U.S. GPM)

Yuken Logic Valves comprise cartridge typed elements and covers with pilot passages. Various types may be combined for direction, flow rate and pressure control.

Yuken Logic Valves can be incorporated in manifold blocks to form optimum integrated hydraulic circuits and compact hydraulic power units. Being a poppet type, the elements permit high-pressure, high flow rates, high speed and shockless shifting with low pressure drop.

Typical applications include steel mill machines, injection moulding machines, machine tools and so on.

In addition, Yuken Logic Valves cavity specifications conform to ISO standards.

■ Features

- Multifunction performance in terms of direction, flow and pressure can be obtained by combining elements and covers.
- Poppet-type elements virtually eliminate internal leakage and hydraulic locking. Because there are no overlaps, response times are very high, permitting high-speed shifting.
- For high pressure, large capacity systems, optimum performance is achieved with low pressure losses.
- Since the logic valves are directly incorporated in cavities provided in blocks, the system is free from problems related to piping such as oil leakage, vibration and noise, and higher reliability is achieved.
- Multi-function logic valves permit compact integrated hydraulic systems which reduce manifold dimensions and mass and achieve lower cost conventional types.

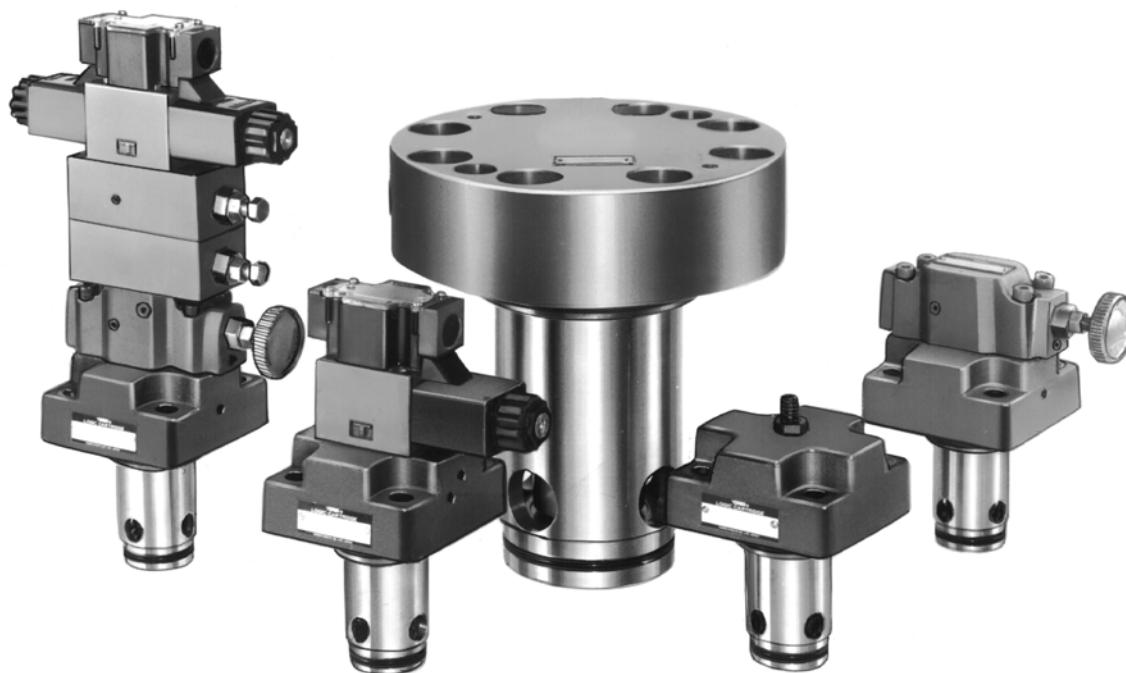
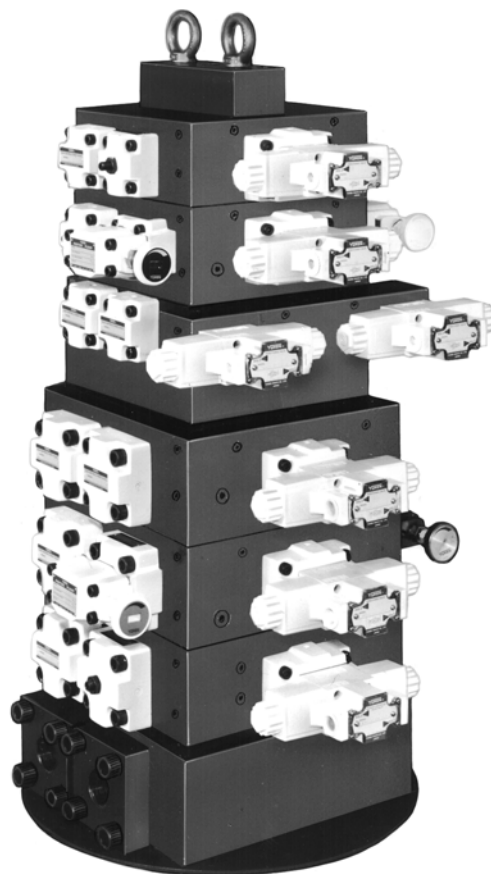

Note: Please refer to the catalogue (No. Pub.JC-1600-1) for the logic valves for details about each performance characteristics and dimensions.

Structure and Functions

As shown below, a logic valve consists of a cover, a sleeve, poppets and a spring incorporated in a block. Although it is a simple 2-port valve designed to open and close the poppets in accordance with the pressure signals from the pilot line, it serves as a multifunctional valve for controlling the direction, flow and pressure by controlling the pressure signals. Standard covers have several pressure signal ports (pilot ports) and control valves for control purposes are available. The covers are spigot mounted. There is no risk of oil leakage.

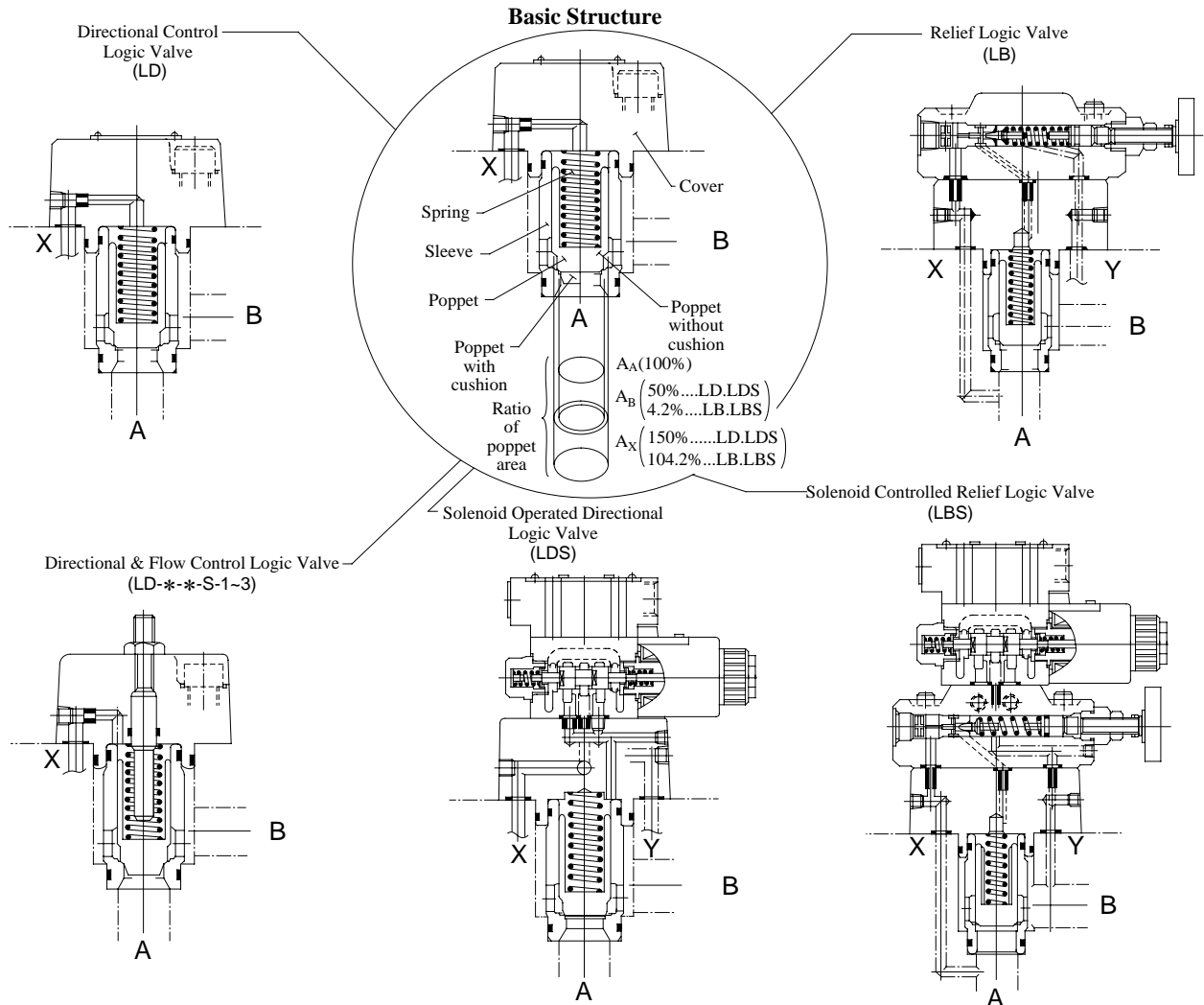

Functions, working area ratios and features

Function	Graphic Symbols	Working area ratio (AA : AB)	Features
Direction		(2 : 1)	<ul style="list-style-type: none"> Poppet shape Without cushion (LD/LDS-*-*): high-speed shift / With cushion (LD/LDS-*-*-S): Shockless shift No leakage between port A and B Flow A to B and B to A are possible Response time and shock can be adjusted by orifice selection.
Direction and Flow			<ul style="list-style-type: none"> Poppet shape With cushion (LD-*-S-1/2/3): flow control. No leakage between port A and B Flow A to B only is possible. Response time and shock can be adjusted by orifice selection.
Relief		(24 : 1)	<ul style="list-style-type: none"> Remote and unloading control is possible with vent circuit (LB-*-*). Two or three pressure controls are possible in combination of solenoid operated directional valve and pilot relief valve (LBS-*-*).

These valves are 2-way directional valves designed to open and close the circuits in accordance with pressure signals from the pilot lines. They are used as multifunctional valves for controlling flow directions or flow directions and rates. Standard covers provided with a choice of several control valves are available so that optimum valves can be selected for control purposes.



LD-32



LD-80

Specifications

Model No.	Rated Flow L/min (U.S.GPM)	Max. Operating Pressure MPa (PSI)	Cracking Pressure MPa (PSI)	Ratio of Poppet Area	Approx. Mass kg(lbs.)
LD-16	130 (34.3)	31.5 (4570)	Refer to Model No. Designation	2 : 1 (Annular area 50%)	1.6 (3.5)
LD-25	350 (92.5)				3.0 (6.6)
LD-32	500 (132)				5.3 (11.7)
LD-40	850 (225)				9.1 (20.1)
LD-50	1400 (370)				14.8 (32.6)
LD-63	2100 (555)				29.8 (65.7)
LD-80	3400 (898)				48 (106)
LD-100	5500 (1453)				86 (190)

Note: The rated flow is values with a pressure drop of 0.3 MPa (44 PSI) [fluid viscosity 35 mm²/s (164 SSU)].

Model Number Designation

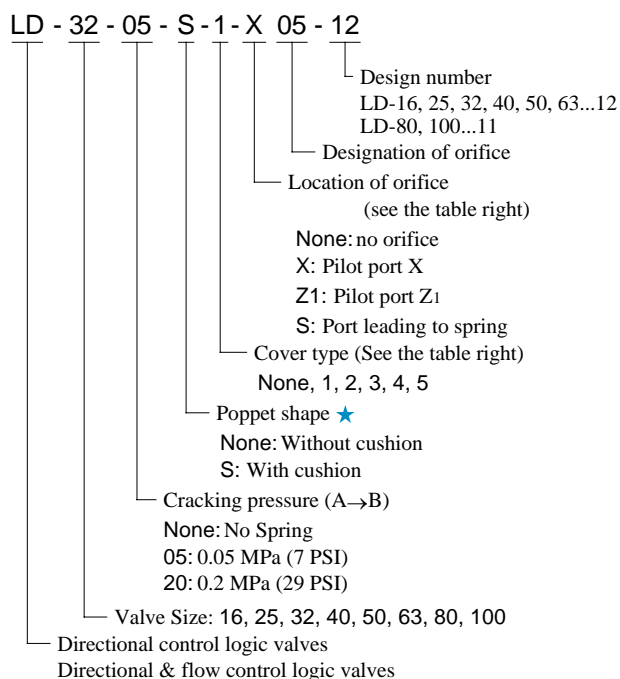

★ Poppet shapes

The type without a cushion and the type with a cushion are both suitable for high-speed shifting and shockless shifting respectively. For directional and flow control logic valves, be sure to specify "poppets with cushions".

List of Cover Types

Cover Type Designation	Graphic Symbols	Valve Size							
		16	25	32	40	50	63	80	100
Directional Control	Standard (None)	○	○	○	○	○	○	○	○
	With Check Valve (4)	○	○	○	○	○	○	—	—
	With Shuttle Valve (5)	○	○	○	○	○	○	—	—
Directional & Flow Control	With Stroke Adjuster (1)	○	○	○	○	○	○	○	○
	With Check Valve & Stroke Adjuster (2)	○	○	○	○	○	○	—	—
	With Shuttle Valve & Stroke Adjuster (3)	○	○	○	○	○	○	—	—



These solenoid operated directional control logic valves are composed of directional control valves and solenoid operated directional valves combined together. The solenoid operated directional valves serve to switch pilot lines and the directional control valves are used to control the direction of the main circuits. Covers provided with various control valves are available to provide optimum control.



Specifications

Model No.	Rated Flow L/min (U.S.GPM)	Max. Operating Pressure MPa (PSI)	Cracking Pressure MPa (PSI)	Ratio of Poppet Area	Approx. Mass kg(lbs.)
LDS-25	350 (92.5)	31.5 (4570)	Refer to Model No. Designation	2 : 1 (Annular area 50%)	4.4 (9.7)
LDS-32	500 (132)				6.7 (14.8)
LDS-40	850 (225)				10.5 (23.2)
LDS-50	1400 (370)				18.6 (41.0)
LDS-63	2100 (555)				33.6 (74.1)

Note: The rated flow is values with a pressure drop of 0.3 MPa (44 PSI) [fluid viscosity 35 mm²/s (164 SSU)].

List of Cover Types

Cover Type Designation	Graphic Symbols	Valve Size				
		25	32	40	50	63
Normally Closed (1)		<input type="radio"/>	<input type="radio"/>	<input type="radio"/>	<input type="radio"/>	<input type="radio"/>
Normally Open (2)		<input type="radio"/>	<input type="radio"/>	<input type="radio"/>	<input type="radio"/>	<input type="radio"/>
Normally Closed with Shuttle Valve (3)		<input type="radio"/>	<input type="radio"/>	<input type="radio"/>	<input type="radio"/>	<input type="radio"/>
Normally Open with Shuttle Valve (4)		<input type="radio"/>	<input type="radio"/>	<input type="radio"/>	<input type="radio"/>	<input type="radio"/>
Normally Closed with Shuttle Valve (5)		<input type="radio"/>	<input type="radio"/>	<input type="radio"/>	<input type="radio"/>	<input type="radio"/>
Normally Open with Shuttle Valve (6)		<input type="radio"/>	<input type="radio"/>	<input type="radio"/>	<input type="radio"/>	<input type="radio"/>

Model Number Designation

LDS - 32 - 05 - S - 1 - O - X05 - A100 - C - N - 13

- Design No.
- Type of electrical conduit connection
 - None: Terminal box
 - N: Plug-in connector
- Type of manual override
 - None: Manual override pin
 - C: Push button and lock nut (Option)
- Coil type
 - A*: AC, R*: AC→DC rectified
 - D*: DC, RQ*: AC→DC rectified (quick return)
- Designation of orifice
- Location of orifice
 - None: No orifice
 - P: Pilot port P, B: Pilot port B
 - A: Pilot port A, X: Pilot port X
- Solenoid operated valve
 - None: With solenoid operated valve
 - O: Without solenoid operated valve
- Cover type (See the table right) 1, 2, 3, 4, 5, 6
- Poppet shape
 - None: Without cushion
 - S: With cushion
- Cracking pressure (A→B)
 - None: No spring
 - 05: 0.05 MPa (7 PSI)
 - 20: 0.2 MPa (29 PSI)
- Valve Size: 25, 32, 40, 50, 63
- Solenoid operated directional control logic valve

Note: In case of LDS-***-***-O (without solenoid operated valve), the graphic symbol for the solenoid operated valve is excluded.

These relief logic valves are used to protect pumps and control valves from excessive pressure and control the pressures of their hydraulic lines at constant levels. With the help of vent lines, they are also capable of remote and unload control.



Specifications

Model Numbers	Max. Operating Pressure MPa (PSI)	Pres. Adj. Range MPa (PSI)	Max. Flow L/min (U.S.GPM)	Approx. Mass kg(lbs.)
LB-16-*-*-10	31.5 (4570)	0.4 - 31.5 (60 - 4570)	125 (33)	3.6 (7.9)
LB-25-*-*-10			250 (66)	4.5 (9.9)
LB-32-*-*-11			500 (132)	6.7 (14.8)
LB-50-*-*-11			1200 (317)	16.1 (35.5)

Model Number Designation

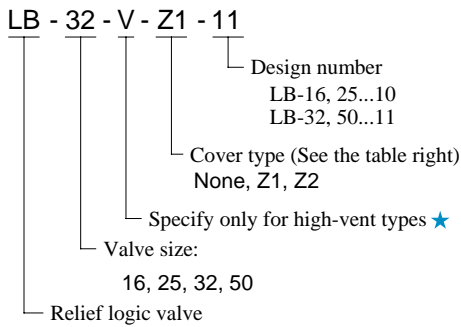

★ Use high-vent pressure types if the shifting time from unloading to on-loading is reduced.

List of Cover Types

Cover Type Designation	Graphic Symbols	Valve Size			
		16	25	32	50
Standard (None)		○	○	○	○
Vent controlled (Z1)		○	○	○	○
Vent controlled (Z2)		○	○	○	○

These solenoid controlled relief logic valves are composite control valves having solenoid controlled directional and pilot relief valves and vent restrictors combined together. This configuration eliminates pipes from the vent circuits of relief logic valves. They are used to put pumps into unloading operation, with the solenoid controlled directional valves serving to select pilot lines, or to place hydraulic system two or three pressure controls, with the pilot relief valves in action.

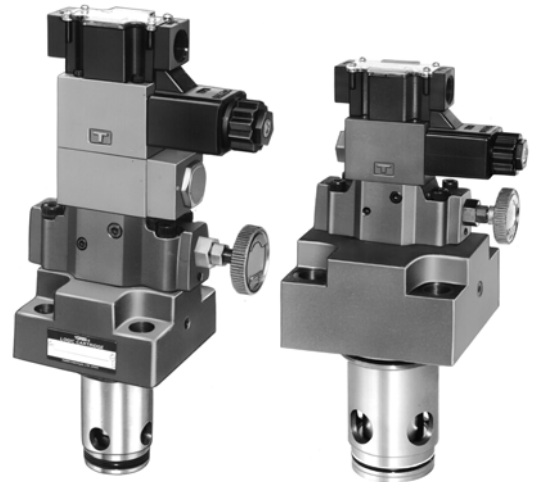

Specifications

Model Numbers	Max. Operating Pressure MPa (PSI)	Pres. Adj. Range MPa (PSI)	Max. Flow L/min (U.S.GPM)	Approx. Mass kg(lbs.)
LBS-16-*-**-13	31.5 (4570)	0.4 - 31.5 (60 - 4570)	125 (33)	8.8 (19.4)
LBS-25-*-**-13			250 (66)	9.7 (21.4)
LBS-32-*-**-13			500 (132)	11.9 (26.2)
LBS-50-*-**-13			1200 (317)	21.3 (47.0)

Model Number Designation

LBS - 32 - V - 1 - A100 - C - N - 13

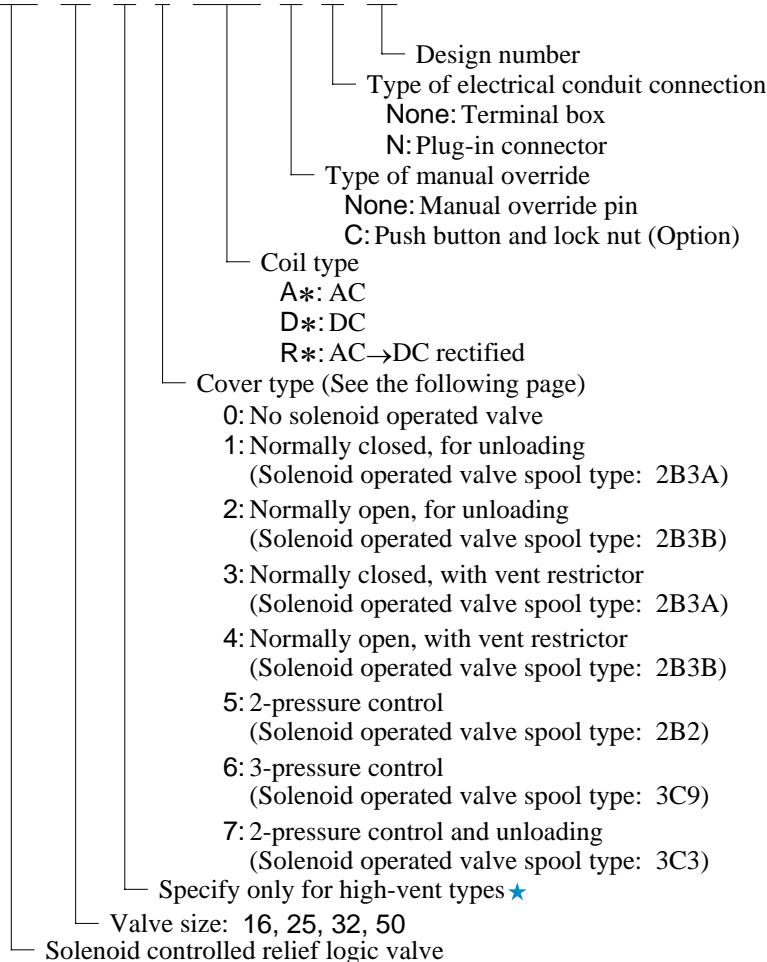

★ Use high-vent pressure types if the shifting time from unloading to on-loading is reduced.

List of Cover Types

Cover Type Designation	Graphic Symbols	Valve Size			
		16	25	32	50
Without Solenoid Valve (0)		○	○	○	○
Normally Closed for Unloading (1)		○	○	○	○
Normally Open for Unloading (2)		○	○	○	○
Normally Closed with Vent Restrictor (3)		○	○	○	○
Normally Open with Vent Restrictor (4)		○	○	○	○
Two-Pressure Control (5)		○	○	○	○
Three-Pressure Control (6)		○	○	○	○
Two-Pressure Control and Unloading (7)		○	○	○	○

