

Fixed displacement axial piston pump type K60N

Max. operating pressure $p_{\max} = 400 \text{ bar (5500 psi)}$
Max. geom. displacement $V_g = 108 \text{ ccm/rev. (61 cu in)}$

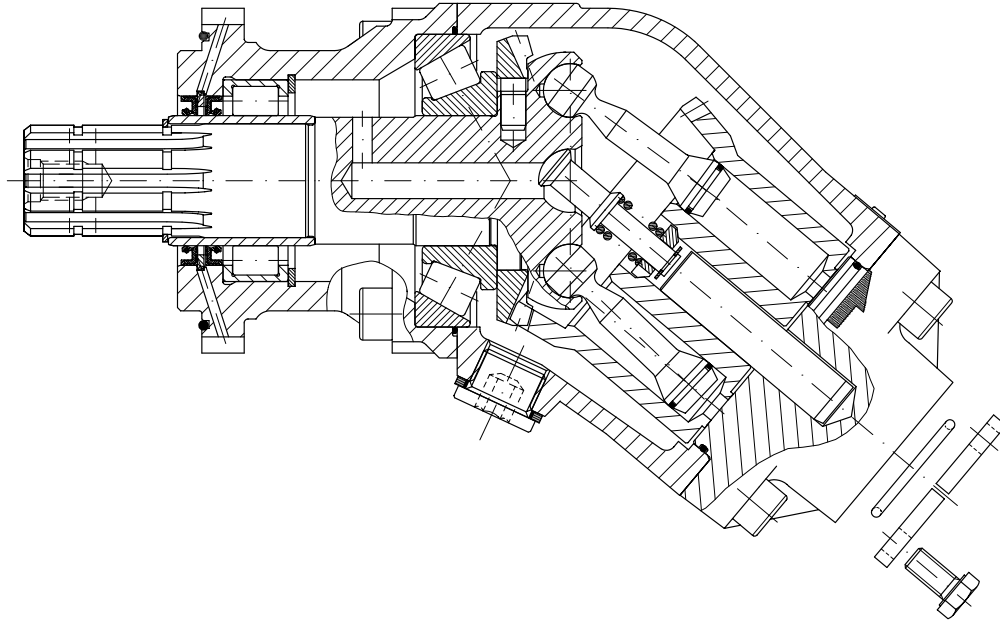
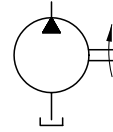

1.2

1. General

The fixed displacement axial piston pump type K 60N (bent axis design) is especially suited for demanding, high-duty service. The pump covers the whole displacement range up to $108 \text{ cm}^3/\text{rev}$. The pump has been developed with modern styling and design to satisfy market demand as to high flow performance, high pressures with high efficiency and very small dimensions. The pump is available both to DIN and SAE standards and can be mounted either directly at the gear box or via a drive shaft. If necessary it can also be augmented with a by-pass valve.

The pumps have the following advantages:

- High speed rating
- Low noise level
- Smooth running and long bearing life
- External fluid leaks are eliminated by using O-rings at all sealing surfaces
- Optional by-pass valve

2. Available versions, main data

Order example:

K60N - 064 L SC N
K60N - 108 R D N - S-F12 - A45/76

Basic type

Nom. size (table 1)

Direction of rotation:

R = clockwise
L = counter clockwise

Suction connections, see table 2

By-pass-valve: **S-F12** = NO-type, solenoid voltage 12V DC
S-F24 = NO-type, solenoid voltage 24V DC

Shaft seals: **N** = NBR (Nitril)
V = FKM (Viton)

Shaft design and mounting flange:

D = Spline shaft (DIN ISO 14), with flange ISO 7653-1985
SB = Spline shaft with flange SAE-B (nom. size 025, 034, 047, 064)
SC = Spline shaft with flange SAE-C (nom. size 047, 064, 084, 108)

Table 1: Nom. size

Coding		012	017	025	034	047	064	084 984 ²⁾	108 9108 ²⁾
Geom. displacement	(ccm/rev.)	12.6	17.0	25.4	34.2	47.1	63.5	83.5	108.0
Flow (theor.)	(lpm)								
at	500 rpm	5.8	7.9	12.5	17.0	23.5	31.5	41.5	54.0
	1000 rpm	12.0	16.2	25.0	34.0	47.0	63.5	83.5	108.0
	1500 rpm	18.3	24.7	37.5	51.0	70.5	95.5	125.0	162.0
Speed	intermittent ¹⁾ n _{max} (rpm)	3000	3000	3000	3000	2500	2500	2000 / 2200	2000 / 2300
	continuous n _{nom} (rpm)	2300	2300	2300	2300	1900	1900	1500 / 1600	1500 / 1900
Operating pressure	p _{max} (bar)	400	400	400	400	400	400	400	400
Mass (weight)	(kg)	8.1	8.1	8.1	8.1	11.7	11.7	17.0	17.0
Tare-weight torque	(Nm)	6.9	6.9	7.4	7.4	13	13	21	21

1) Intermittent operation, duty cycle of max. 10 sec./min

2) Pump types K60N-984 resp. -9108 are specially designed highspeed-versions, the back cover can not be turned to reverse the direction of rotation.

Main data by-pass valve

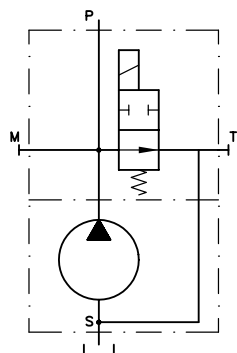

Coding	S - F12	S - F24
Nom. voltage	12 V DC	24 V DC
Nom. power	12 W	12 W
Protection class	IP 66	IP 66

Nom. size	012 to 064	084 to 108
Mass (weight)	2.0 kg	2.4 kg

Table 2: Suction connections

Order examples: K 60 N - 084 RDN - **A6**
K 60 N - 025 LDN - **A 45 / 38**

Nom. size
Geometric shape

Size	Nom. size	Q _{max} (l/min)	straight	45°	90°	thread
			A00/..	A45/..	A90/..	A.
012, 017, 025, 034, 047, 064	32	50	●	-	-	-
	38	75	●	●	●	-
	42	90	-	●	-	-
	50	125	●	●	●	-
	5	90	-	-	-	● (G1)
084, 984, 108, 9108	38	75	●	-	●	-
	42	90	-	●	-	-
	50	125	●	●	●	-
	64	160	●	●	●	-
	76	190	●	●	●	-
	6	125	-	-	-	● (G1 1/4)

G.... Δ BSPP

3. Additional versions

3.1. General

Calculation:

Flow rate
$Q = \frac{V_g \cdot n \cdot \eta_v}{1000} \text{ (lpm)}$

Torque
$M = \frac{1,59 \cdot V_g \cdot \Delta p}{100 \cdot \eta_{mh}} \text{ (Nm)}$

Power
$P = \frac{2\pi \cdot M \cdot n}{60000} = \frac{M \cdot n}{9549} = \frac{Q \cdot \Delta p}{600 \cdot \eta_t} \text{ (kW)}$

V_g = Geom. displacement (ccm/rev.)

η_v = Volumetric efficiency

Δp = Diff. pressure (bar)

η_{mh} = Mechanical-hydraulic efficiency

n = Speed (rpm)

η_t = Total efficiency ($\eta_t = \eta_v \cdot \eta_{mh}$)

Working principle	Fixed displacement axial piston pump acc. to bent-axis principle
Installation	P.T.O. of truck gear boxes (flange ISO 7653.1985 for trucks) or flange mounting (flange SAE)
Direction of rotation	Any
Changing of rotating direction	Rotating of end cover (see dimensional drawing) by 180° (not possible with type K60N-984 resp. K60N-9108) max. bolt torque: Nom. size 012...064: 70 Nm Nom. size 084, 108: 100 Nm
Mounting position	Optional
Pressure fluid	Hydraulic fluid (DIN 51524 table 2 and 3); ISO VG 10 to 68 (DIN 51519) Viscosity range: min. 10; max. 700 mm ² /s, Optimal operation range: 20...40 mm ² /s Also suitable are biodegradable pressure fluids of the type HEES (synth. Ester) at operation temperatures up to +70°C.
Temperature	Ambient: -40 ... +60°C Fluid: -25...+80°C, pay attention to the viscosity range! Start temperature down to -40°C are allowable (Pay attention to the viscosity range during start-up!), as long as the operation temperature during consequent running is at least 20K (Kelvin) higher.
Filtration	Min. conforming ISO standard 4406 code 16/13.
Start-up	Suction pipe should be as big as possible (see also selection of suction connections in table 2). Flexible hoses should be fixed by two strong hose straps. Suction filter should not be assembled. All hydraulic lines should be flushed with appropriate hydraulic fluid before start-up. The pump case should then be bled via the uppermost drain port. Note: The surroundings should be clean while filling the pump. Check the rotation direction of drive and pump prior to initial operation. At start-up and during the first few minutes of the operation the pressure relief valve should be set to 50 bar (700 psi) or less.

4. Unit dimensions

All dimensions in mm, subject to change without notice!

	K
K 60 N - 12...108.D	B8x32x34.9 DIN ISO 14
K 60 N - 025...064.SB	13 T 7/8"
K 60 N - 047...108.SC	14 T 1 1/4"

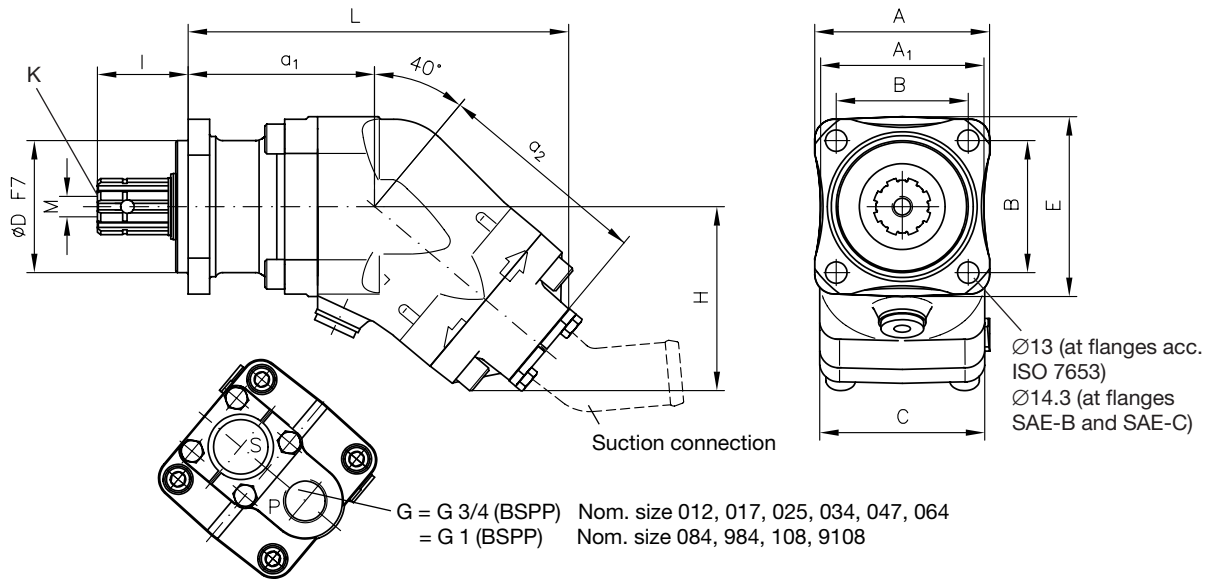

Nom. size	L	H	A	A ₁	B ¹⁾	C	ØD ¹⁾	E	I ¹⁾	a ₁ ¹⁾	a ₂ ¹⁾	M ¹⁾
12	202	97	97	89	80/-/-	87	80/-/-	99	55/-/-	97/-/-	112	12/-/-
17	202	97	97	89	80/-/-	87	80/-/-	99	55/-/-	97/-/-	112	12/-/-
25	202	97	97	89	80/89.8/-	87	80/101.6/-	99	55/41/-	97/101/-	112	12/-/-
34	202	97	97	89	80/89.8/-	87	80/101.6/-	99	55/41/-	97/101/-	112	12/-/-
47	228	109	106	99	80/89.8/114.5	95.5	80/101.6/127	109	55/41/56	113/117/119	130	12/-/-
64	228	109	106	99	80/89.8/114.5	95.5	80/101.6/127	109	55/41/56	113/117/119	130	12/-/-
84	259	126	123	115	80/-/114.5	115	80/-/127	126	55/-/56	123/-/128	147	12/-/-
108	259	126	123	115	80/-/114.5	115	80/-/127	126	55/-/56	123/-/128	147	12/-/-

1) Dimensions of flanges acc. ISO 7653-1985 / flanges SAE-B / flanges SAE-C

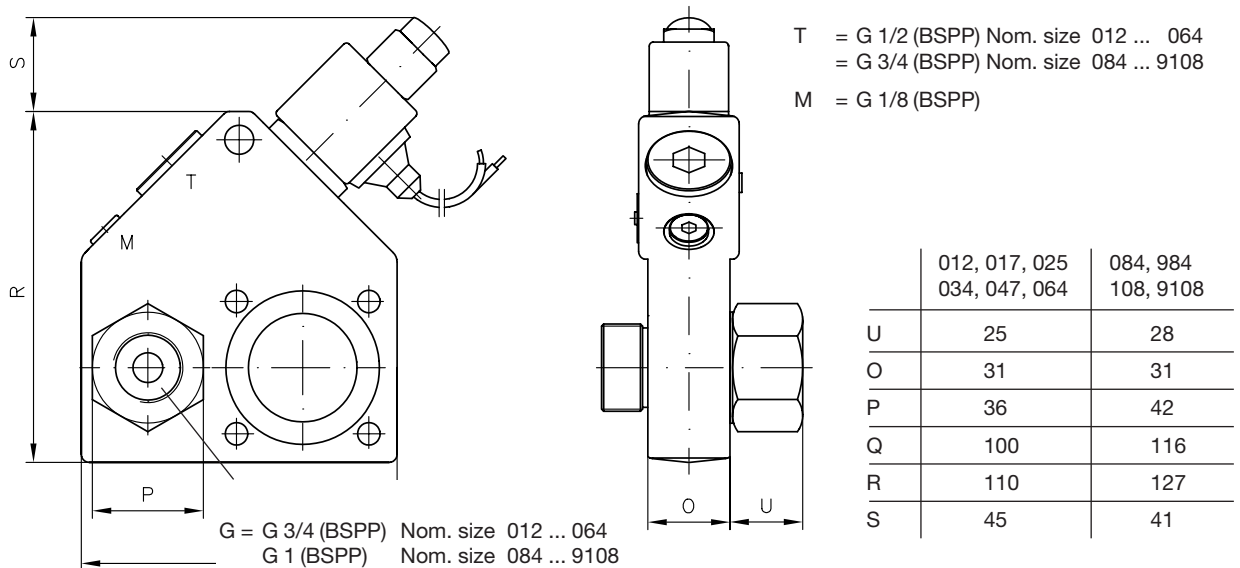

Suction connections

