

# InLine variable displacement axial piston pump type V30

The InLine variable displacement pump type V30D and V30E work according to the swash plate principle and are intended for open circuit operation in industrial and mobile hydraulics. There is also an option for a thru-shaft for flange mounting additional variable and fixed displacement pumps. Type V30E is intended as successor of V30D, where the completely new development allowed to realize state of the art pump design. This concerns primarily the optimization of self-suction speed rating, minimized noise level, weight, and pulsation as well as increased service life.

These pumps are suited for a wide range of applications due to their low running noise and various pump controllers.

Hydraulic circuits where several outlet flows are required can be fed either by one individual pump or a multiple pump. Main benefit of these pumps are the sturdy design, the good performance/weight ratio, long service life due to oversized bearings, and the swash plate angle indicator.



**Nomenclature:** Variable displacement axial piston pump

**Design:** Individual pump  
Pump combination

**$p_{max}$ :** 350 bar (continuous)  
420 bar (peak)

**$Q_{max}$ :** 65 ... 392 lpm  
(1450 rpm)

**$V_{g max}$ :** 45 ... 270 cm<sup>3</sup>/rev

## Basic type and main parameter

Basic type	Geom. displacement $V_g$ (cm <sup>3</sup> /rev)	Delivery flow $Q_{max}$ (lpm) <sup>1)</sup>	Nom. pressure $p_{nom}$ (bar) <sup>3)</sup>	Self-suction speed $n$ (rpm)
<b>V30E -095</b>	95	139	350 (420)	2600
<b>-160</b>	160	232	350 (420)	2100
<b>-270</b>	270	392	350 (420)	1900
<b>V30D -045</b>	45	65	350 (420)	2600
<b>-075</b>	75	109	350 (420)	2400
<b>-095</b>	95	139	350 (420)	2200
<b>-115</b>	115	167	250 (300) <sup>2)</sup>	2000
<b>-140</b>	140	206	350 (420)	2200
<b>-160</b>	160	238	250 (300) <sup>2)</sup>	1900
<b>-250</b>	265	380	350 (420)	1800

## Symbols

### Individual pump

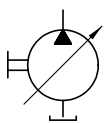

### Multiple pump

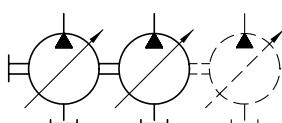

## Additional versions (basic types)

- Double pumps (tandem or twin version)  
Additional pumps may be mounted directly via flanges conforming to SAE-A, B, C, D.
- Variable displacement pumps for closed circuits

## Type coding

**V 30 D - 095 R K N - 1 - 1 - XX / LN - 2/120 - 200**

Basic type and nominal size	Pressure specification (bar)
Direction of rotation:	Torque setting (Nm): Specification alternatively to power (kW) and revolutions per minute (rpm)
<b>L</b> = Counter clockwise	Special versions: <b>1</b> = Prep. for retrofitting of controller L <b>2</b> = Max. stroke limitation
<b>R</b> = Clockwise	See "Controllers"
Shaft journal:	Design
<b>D</b> = Spline shaft (DIN 5480)	Swash plate angle indicator: <b>0</b> = No indicator <b>1</b> = With indicator <b>2</b> = Swivel angel transducer
<b>K</b> = With key	Shaft design: <b>1</b> = Standard <b>2</b> = Thru-shaft journal
<b>S</b> = Spline shaft with SAE flange	
Seals:	
<b>N</b> = NBR (Nitril)	
<b>E</b> = EPDM	
<b>V</b> = FKM	

1) Approximate reference value at 1450 rpm

2) Higher pressure is possible with reduced geom. displacement

3) Figures in brackets =  $p_{max}$  (bar)

**Controllers type V30D and V30E**

**Description (type)**

- Power controller: L - Limitation of the driving torque  
L1 - Option of limiting the flow
- Load-Sensing-controller: LS - For proportional directional spool valves (LS)  
LSN - With pressure limitation
- Pressure controller: N - Suited for constant pressure systems  
P - With remote control port  
Pb - With remote control port for systems tending to oscillations
- Flow controller: Q - For maintaining a constant flow  
Qb - For maintaining a higher pump speed
- V - Electro-hydraulic proportional control of the pump delivery via electronic control card (V.E)
- VH - Controller with hydraulic prop. control of the pump delivery

**Dimensions**

(see order example)

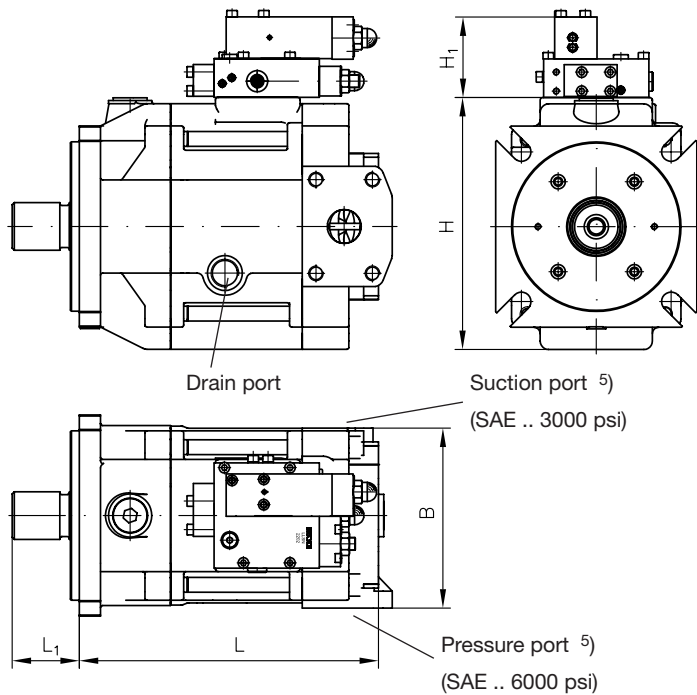

**Order examples**

**V30E - 160 R D N - 1 - 1 - 01 / LSN - 250**

Pump type V30E, nom. size 160, for clockwise rotation and spline shaft (DIN 5480) and NBR seals, standard shaft (no thru-shaft). Pump with swash plate dial indicator, Load-Sensing-controller and pressure limitation, LSN-controller with operation pressure set for max. 250 bar.

Basic type	L	L1	B	H	H1	m (kg)
	approx.	approx.	approx.	approx.	approx.	
<b>V30E -095</b>	300	63	190	190	50	59
<b>-160</b>	330	65	210	210	50	92
<b>-270</b>	399	79	242	326	50	126
<b>V30D -045</b>	268	68	160	150	82	40 (46)
<b>-075</b>	310	80	178	170	86	60 (66)
<b>-095</b>	341	93	196	196	87	70 (76)
<b>-115</b>	341	93	196	196	87	70 (76)
<b>-140</b>	363	90	212	212	85	85 (91)
<b>-160</b>	363	90	212	212	85	85 (91)
<b>-250</b>	432	115	272	224	97	130 (136)

Basic type	Drain port	Auxiliary conn. <sup>6)</sup>	Suction port	Pressure port
	<sup>6)</sup>	<sup>6)</sup>		
<b>V30E -095</b>	G 3/4	-	2 1/2"	1 1/4"
<b>-160</b>	G 3/4	-	2 1/2"	1 1/4"
<b>-270</b>	G 1	-	3"	1 1/2"
<b>V30D -045</b>	G 1/2	G 1/4	1 1/2"	3/4"
<b>-075</b>	G 3/4	G 1/4	2"	1"
<b>-095</b>	G 3/4	G 1/4	2"	1 1/4"
<b>-115</b>	G 3/4	G 1/4	2"	1 1/4"
<b>-140</b>	G 3/4	G 1/4	2 1/2"	1 1/4"
<b>-160</b>	G 3/4	G 1/4	2 1/2"	1 1/4"
<b>-250</b>	M33x2	Rohr Ø8	3"	1 1/2"

All dimensions in mm, subject to change without notice!

<sup>4)</sup> Figures in brackets with controller  
<sup>5)</sup> Location of the ports for clockwise rotation  
<sup>6)</sup> BSPP-ports

**Additional information**

- InLine variable displacement axial piston pump type V30D D 7960  
type V30E D 7960 E  
type V30Z D 7960 Z
- Variable displacement axial piston pump type V60N D 7960 N
- Axial piston motor type M60N D 7960 M
- Fixed displacement axial piston pump type K60N D 7960 K
- Prop. amplifier type EV1M2 D 7831/1
- Programmable logical valve control type PLVC D 7845 ++

- Prop. directional spool valve size PSL/PSV size 2 D 7700-2  
size PSL/PSV size 3 D 7700-3  
size PSL/PSV size 5 D 7700-5  
size PSLF/PSVF size 3/5 D 7700-F

• see also section "Devices for special applications" (mobile hydraulics)

For section and page of the additionally listed devices, see type index