

# InLine variable displacement axial piston pump type V60N

The InLine variable displacement pump type V60N works according to the swash plate principle usually driven via the ancillary drive. It is intended for open circuit operation in mobile hydraulics. In optional thru-shaft enables direct mounting of additional variable displacement pumps or a feed pump. These pumps are suited for a wide range of applications due to their low running noise and various pump controllers. The direct mounting at the gear box is either via a SAE-flange or a flange conforming ISO 7653. The flange area at the suction port enables optimized hose connection with little back

pressure. Main benefit of these pumps are the sturdy design, the good performance/weight ratio and long service life due to oversized bearings.



**Nomenclature:** Variable displacement axial piston pump

**Design:** Individual pump  
Pump combination

**$P_{max}$ :** 350 bar (continuous)  
420 bar (peak)

**$Q_{max}$ :** 130 ... 160 lpm  
(1450 rpm)

**$V_{g max}$ :** 60 ... 110 cm<sup>3</sup>/rev

## Basic type and main parameter

Basic type	Geom. displacement	Delivery flow	Nom. pressure	Self-suction speed
	$V_g$ (cm <sup>3</sup> /rev)	$Q_{max}$ (lpm) <sup>1)</sup>		
<b>V60N -060</b>	60	87	350 (400)	2700
<b>-090</b>	90	130	350 (400)	2400
<b>-110</b>	110	160	350 (400)	2200

## Symbols

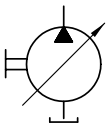

## Additional versions (basic types)

- Double pumps

Additional pumps may be mounted directly via flanges conforming to SAE-A

## Type coding

**V 60 N - 110 R SU N - 1 - 0 - 03 / LSN - 2 - 320**

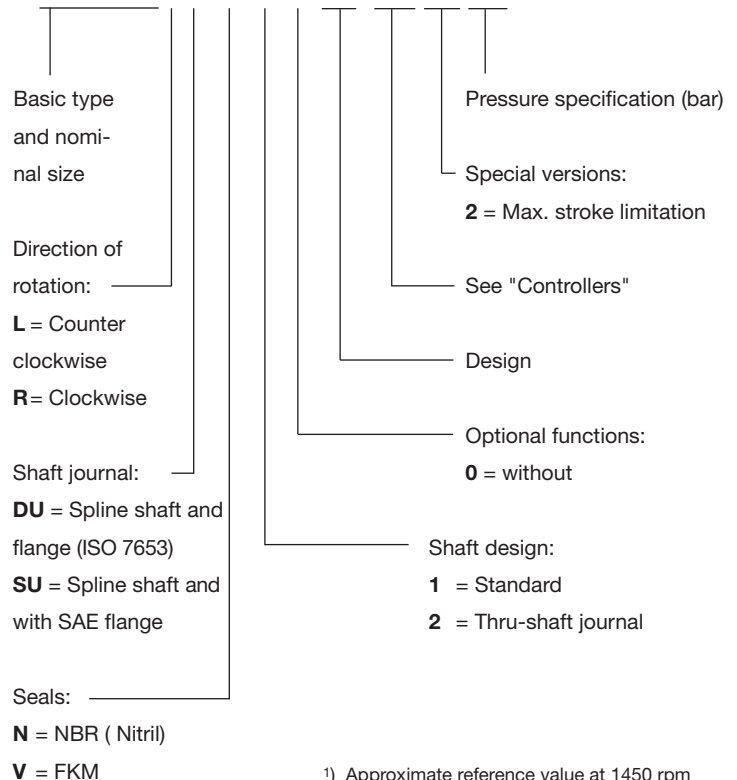

<sup>1)</sup> Approximate reference value at 1450 rpm

<sup>2)</sup> Figures in brackets =  $P_{max}$  (bar)

**Controllers type V60N**

**Description (type)**

- Power controller: L - Limitation of the driving torque
- Load-Sensing-controller: LSN - For proportional directional spool valves with pressure limitation
- Pressure controller: N - Suited for constant pressure systems

**Order examples**

**V60N - 090 R DU N - 1 - 0 - 01 / LSN - 2 - 320**

Pump type V60N, nom. size 090, for clockwise rotation suited for truck ancillary drives (DU) and NBR seals, standard shaft (no thru-shaft). Load-Sensing-controller and pressure limitation, stroke limitation (coding 2), LSN-controller with operation pressure set for max. 320 bar.

**Dimensions**

(see order example)

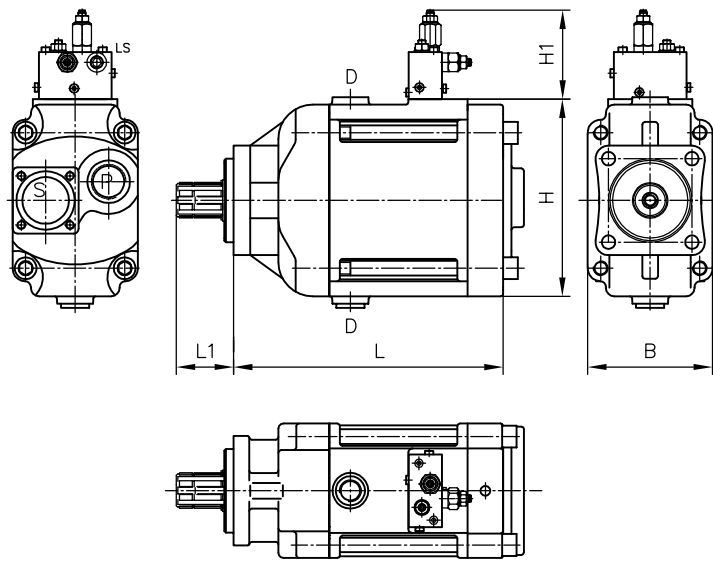

Basic type	L	L1	B	H	H1	m (kg)
V60N-060	254	55	115	181	50	23
-090	277	55	120	189	50	26.7
-110	279	55	125	191	50	29

All dimensions in mm, subject to change without notice!

**Ports at type V60N-090 (-110):**

- P = Pressure outlet G 1 (BSPP)
- S = Suction port  $\varnothing$  1 1/2
- D = Leakage port G 1/2 (BSPP)
- LS = LS-signal port G 1/4 (BSPP)

**Additional information**

- Variable displacement axial piston pump type V60N D 7960 N
- Axial piston motor type M60N D 7960 M
- Fixed displacement axial piston pump type K60N D 7960 K
- InLine variable displacement axial piston pump
  - type V30D D 7960
  - type V30E D 7960 E
  - type V30Z D 7960 Z
- Prop. directional spool valve type PSL/PSV size 2 D 7700-2
  - type PSL/PSV size 3 D 7700-3
  - type PSL/PSV size 5 D 7700-5
  - type PSLF/PSVF size 3/5 D 7700-F

- Load holding valves type LHK D 7100
- type LHDV D 7770
- type LHT D 7918
- see also section "Devices for special applications" (mobile hydraulics)

For section and page of the additionally listed devices, see type index