

Radial piston pumps type R and RG

The radial piston pumps consist of radially arranged, valve controlled pump cylinders. Higher delivery flows can be created by stacking up to 6 radials on a common shaft. The pump is usually driven by an electric motor, which is connected with the pump by means of a bell housing and a coupling.

The closed pump housing permits "in tank" installation (hydraulic power pack) as well as the common external pump/ motor installation (pump with motor). The possibility of a radial piston pump with several pressure outlets (several equal or differing delivery flows) is particularly innovative. Type RG utilizes slide bearings and is intended for extreme application

conditions to increase the service life.

Complete hydraulic control systems can be created by directly mounting various connection blocks and valve banks to the cover plate of the hydraulic power pack.



Nomenclature:	Radial piston pump
Design:	Individual pump Pump complete with motor Hydraulic power pack
p_{max}:	700 bar
Q_{max}:	91.2 lpm ($V_g = 64.18 \text{ cm}^3/\text{rev}$)
$V_{max \text{ tank}}$:	approx. 470 l

Symbols

Individual pump

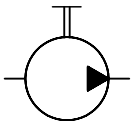

Pump complete with motor

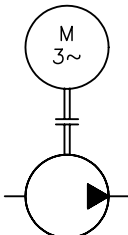

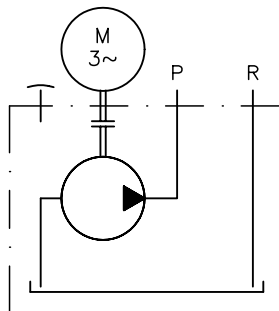

Hydraulic power pack

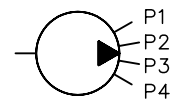

Pump with several pressure outlets
(example for on individual pump)

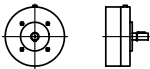
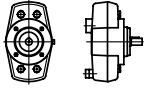

Basic types and general parameters

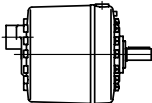
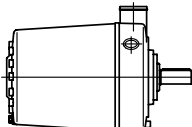
Design	Number of cylinders	Version R or RG with delivery flow Q_{pu} (lpm) (approximate reference value at 1450 rpm) and max. pressure p_{max} (bar) ¹⁾				
		700 bar	550 bar	450 bar	250 bar	160 bar
7631 	2	R 0,18	R 0,28	R 0,43	R 0,92	
	3	R 0,27	R 0,42	R 0,64	R 1,35	
	5	R 0,46	R 0,7	R 1,08	R 2,27	
6010 	1	R(G) 0,3	R(G) 0,5	R(G) 0,8	R(G) 1,7	R(G) 2,2
	2	R(G) 0,6	R(G) 1,0	R(G) 1,6	R(G) 3,3	R(G) 4,4
	3	R(G) 0,9	R(G) 1,5	R(G) 2,5	R(G) 5,1	R(G) 6,5
6011 	5	R(G) 1,4	R(G) 2,6	R(G) 4,2	R(G) 8,3	R(G) 10,9
	7	R(G) 2,1	R(G) 3,7	R(G) 5,8	R(G) 11,8	R(G) 15,3
6012 	10	R(G) 2,7	R(G) 5,3	R(G) 8,2	R(G) 16,8	R(G) 21,7
	14	R(G) 4,0	R(G) 7,4	R(G) 11,6	R(G) 23,5	R(G) 30,4
6014 	20	R(G) 6,1	R(G) 11,0	R(G) 17,4	R(G) 35,0	R(G) 43,4
	28	R(G) 8,0	R(G) 15,0	R(G) 23,0	R(G) 47,0	R(G) 60,8
6016 	42	R(G) 12,7	R(G) 22,0	R(G) 34,5	R(G) 70,0	R(G) 91,2

Additional parameter

Design	Drive power	Tank sizes
	rating P_N (kW) ²⁾	(optional) V_{usable} (l)
7631	0.25...0.55	6...45
6010	0.25...3	6...80
6011	0.55...5.5	6...160
6012	2.2...11	20...160
6014	5.5...22	80...450
6016	11...30	120...450

¹⁾ The parameter listed here represent only a choice from a variety of possibilities.

²⁾ Standard motor, design IM B 35 for pumps complete with motor or IM B 5 for hydraulic power packs.

Order examples

R 5,8

Individual pump, design 6011,

$Q_{pu} = 5.8$ lpm at 1450 rpm $p_{max} = 450$ bar

R 4,0/M 7,5

Pump complete with motor, design 6012,

$Q_{pu} = 4.0$ lpm at 1450 rpm, $p_{max} = 700$ bar, motor $P_N = 7.5$ kW

Additional versions

- Pumps complete with motor (incl. flange a. coupling) and hydraulic power packs also available without motor
- Cover plate version to be installed on customer furnished tanks
- Design with several pressure ports
- One or two pump cylinders individually routed out ($Q_{max} = 4.4$ lpm) e.g. for control oil supply
- Integrated switch-off valve with two pressure ports
- Version with DC-motor (only pump design 6011)

R 11,0/B 75 A 550 - V 15

Hydraulic power pack consisting of radial piston pump,

design 6014, $Q_{pu} = 11.0$ lpm at 1450 rpm, $p_{max} = 550$ bar, tank B 75

(V_{usable} approx. 80 l), directly mounted connection block (coding A..) with pressure limiting valve (550 bar) and electric motor $P_N = 15$ kW

Dimensions

Individual pump

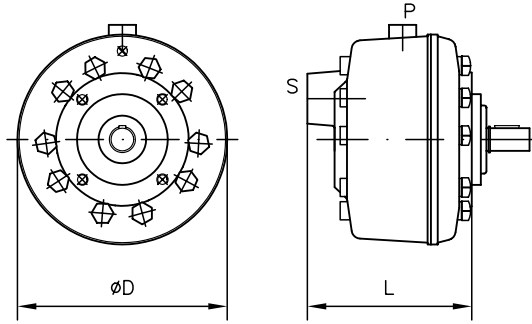

Design	ØD	L	L1 _{max}	m (kg) ³⁾
7631	130	53	109	3.2
6010	174	82.5	113	3.1
6011	185	86	155	5.8
6012	185	146	188	10.5
6014	218	250	188	24.2
6016	238	311	212	39.1

³⁾ Mass of the individual pump

Motor pump

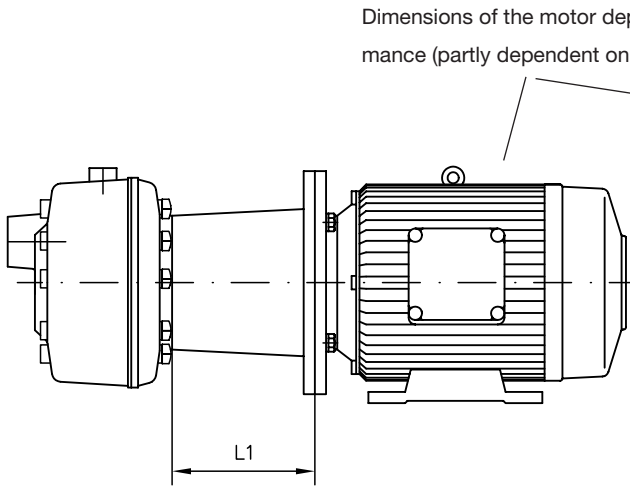

Hydraulic power pack

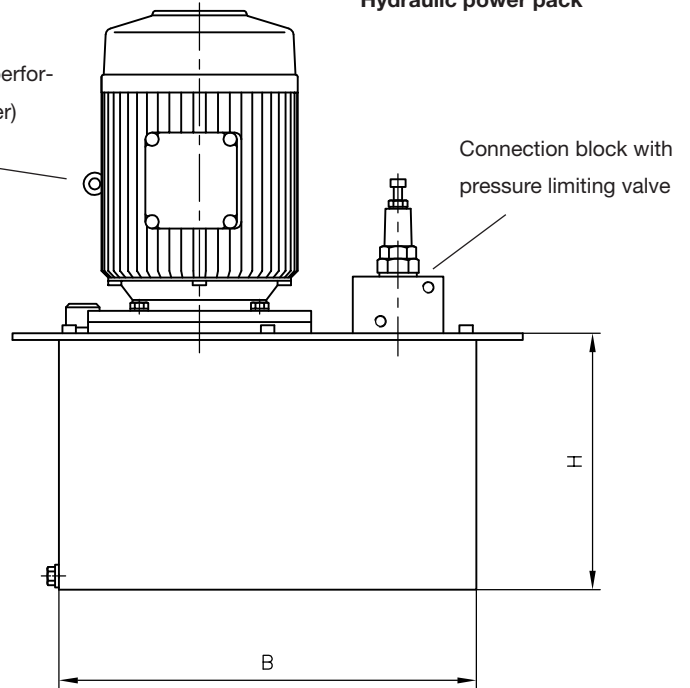

All dimensions in mm, subject to change without notice!

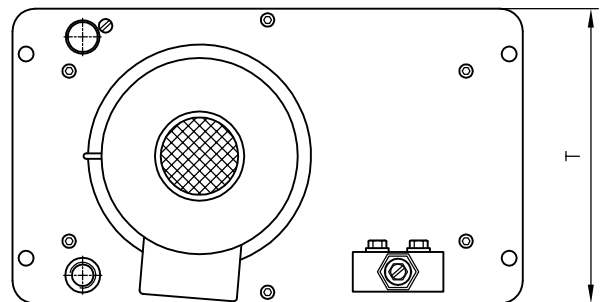

Size	B6	B13	B20	B30	B40	B50	B75	B100	B160	B250	B400
H	230	230	320	320	320	403	478	536	666	575	825
B	253	368	368	448	448	600	600	650	650	1000	1000
T	315	260	260	320	440	420	420	500	500	600	600
V _{max tank} (l)	9.3	17	25	39	55	85	107	152	193	309	469

Circuit example

R 4,0/B 50 A 700 - VB 11 DM - HRHR - 1 - G 24 - V 5,5

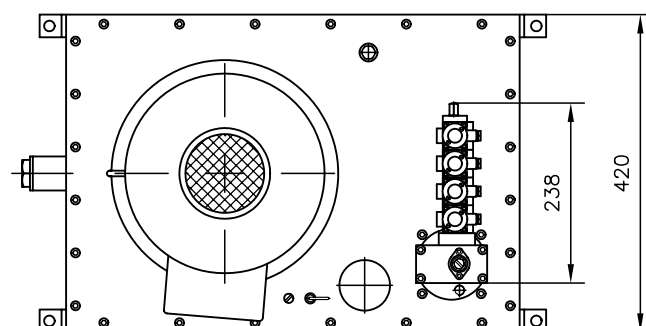
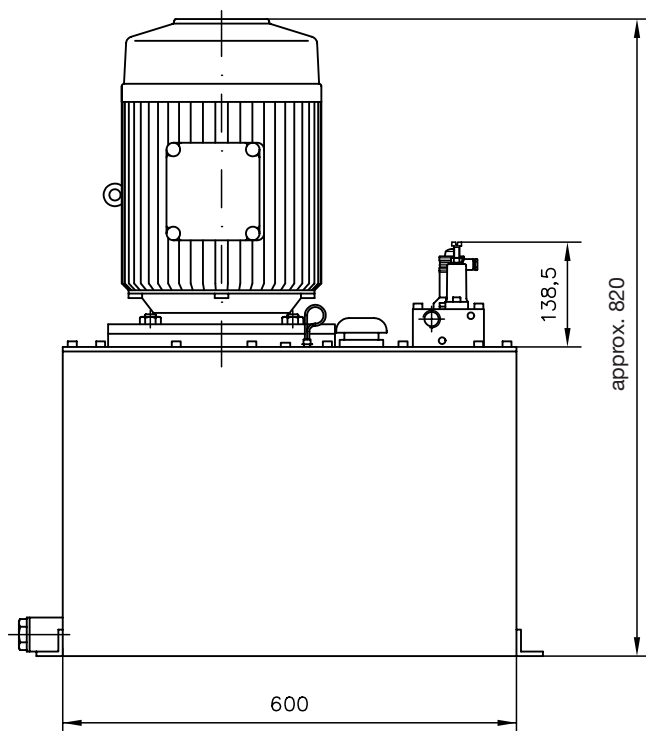
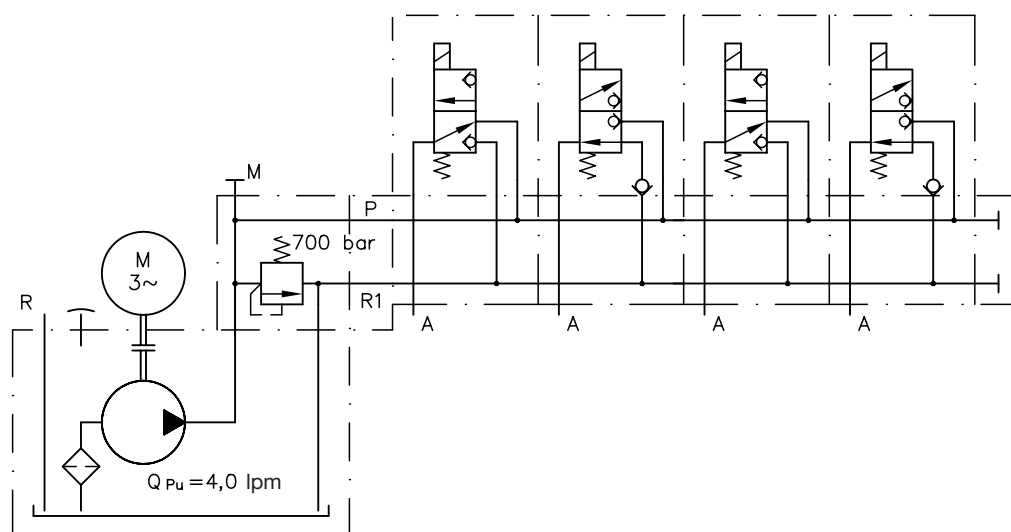

Additional information

- Radial piston pumps type R and RG D 6010
- Pumps complete with motor and hydraulic power packs type R and RG D 6010 H
- Radial piston pump with several pressure ports type R and RG D 6010 D, D 6010 DB
- Radial piston pump with control oil port type R D 6010 S
- Radial piston pump with DC-motor type R D 6010 G
- Hydraulic power packs with gear pump type Z D 6820
- Directly mountable valve banks type VB
 - type BWH(N) D 7302
 - type SWR D 7470 B/1
 - type SKP D 7450, D 7451
 - D 7230
- see also section "Devices for special applications" (Press controls, Devices for up to 700 bar)

For section and page of the additionally listed devices, see type index