

Orifices and restrictor check valves type EB, BE, and BC

The orifice inserts type EB are part of the flow valves, whereas the restrictor check valves type BE and BC are a combination of a flow and check valve.

They are used to limit the flow during switching operations of directional valves (flow restriction preventing too rapid discharging of accumulators). The restrictor check valves type BC and BE, feature an orifice or slot design. They enable free flow in direction $F \rightarrow B$ and throttle the flow in the reverse direction.

Type BC can be installed in both flow directions. The incorporated check valve is spring loaded.

The mounting hole may be shaped with a simple drill (point angle 118°).

The orifice inserts, type EB, can be installed in the P-ports of indiv. sub-plate mounted directional valves.



Nomenclature: Orifice
Restrictor check valve

Design: Orifice insert
Screw-in valve
Version with housing for in-line installation

p_{max} : 400 ... 700 bar

Q_{max} : 0.5 ... 120 lpm

Basic types and general parameters

Size	Basic type and flow pattern			Thread (BSPP) (screw-in valves only - not type EB)
	Screw-in valve		Orifice insert	
	BC	BE	EB	
0	Q_{max}	---	12	G 1/8 A
	p_{max}	---	500	
1	Q_{max}	20	25	G 1/4 A
	p_{max}	700	500	
2	Q_{max}	35	40	G 3/8 A
	p_{max}	700	500	
3	Q_{max}	60	70	G 1/2 A
	p_{max}	500	450	
4	Q_{max}	---	120	G 3/4 A
	p_{max}	---	400	

Available orifices diameter depending on type and size from **0.4** to **4.2** mm

Additional versions

- Type BC and BE with metric thread
- Type BC and BE with housing for in-line installation

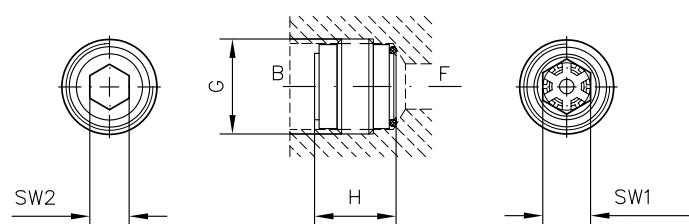
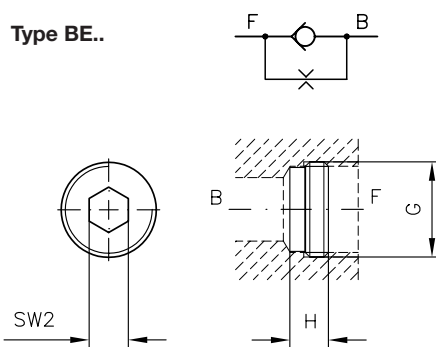
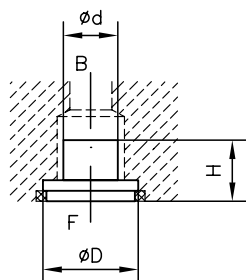
Order examples**BC 1 - 0.8**Restrictor check valve type BC, size 1 with hole type orifice $\varnothing 0.8$ mm**BE 2 - 2.0**Restrictor check valve type BE, size 2 with hole type orifice $\varnothing 2.0$ mm**EB 2 - 1.7**Orifice insert type EB, size 2 with hole type orifice $\varnothing 1.7$ mm**Dimensions****Type BC..** (screw-in direction arbitrary)**Type BE..****Type EB..**

All dimensions are in mm, and subject to change without notice!

Basic type	H	G / D	SW1 / $\varnothing d$	SW2	m (g)
BC 1	13	G 1/4 A	a/f 8	a/f 4	6
BC 2	15	G 3/8 A	a/f 9	a/f 5	10
BC 3	18	G 1/2 A	a/f 12	a/f 8	24
BE 0	5	G 1/8 A	a/f 4		2
BE 1	6	G 1/4 A	a/f 5		4
BE 2	7	G 3/8 A	a/f 8	---	6
BE 3	7.5	G 1/2 A	a/f 10		10
BE 4	9	G 3/4 A	a/f 12		18
EB 0	1.8	6.1	5.5		2
EB 1	1.8	8.1	7.4		4
EB 2	9	14	8	---	6
EB 3	11.5	17	10		10
EB 4	10	28	27		18

G = BSPP

Further information

- Restrictor check valves type BC D 6969 B
type BE D 7555 B
- Orifice inserts type EB D 6465
- Check valves type ER D 7325
- Screw-in check valves type RE D 7555 R
type RC D 6969 R
type RK, RB D 7445
- Screw-in check valves type BSE, QSE, MSE D 7121

- Restrictor check valves type RD, ED, RDF D 7540

• See also section "Devices for special applications"
(Screw-in valves and installation kits)

For page and section of the devices additionally listed,
see type index