

Lifting/lowering valves type HSV

The lifting/lowering valves type HSV are intended for the control of lifting equipment utilizing single acting cylinders. This valve combines the functions of a solenoid actuated 2/2-way directional seated valve for lowering the lifted load, a pressure limiting valve for limiting the permissible load and the option for either an adjustable throttle limiting the lowering rate or a 2-way flow control valve enabling a rather constant lowering rate independent of the lifted load.

Additionally there is a check valve preventing unintended lowering of the load.

The valves are designed for direct pipe connection but may be mounted on customer furnished manifolds as well.



Nomenclature:

Valve combination consisting of:

- 2/2-way directional seated valve, solenoid actuated
 - Pressure limiting valve
 - Check valve
- Optional:
- Throttle or 2-way flow control valve

Design:

Individual valve for pipe connection

Actuation:

Solenoid

P_{max}:

315 ... 400 bar

Q_{max}:

20 ... 120 lpm

Basic types and general parameters

Basic type and size	Flow Q _{max} (lpm)	Oper. pressure p _{max} (bar)	Tapped ports (BSPP)	
			P	A, R
HSV 21	20	315	G 3/8	G 3/8
HSV 22	30	315	G 3/8	G 1/2
HSV 41	40	400	G 1/2	G 1/2
HSV 61	60	350	G 1/2	G 1/2
HSV 71 ¹⁾	120	315	G 3/4	G 3/4

Symbols

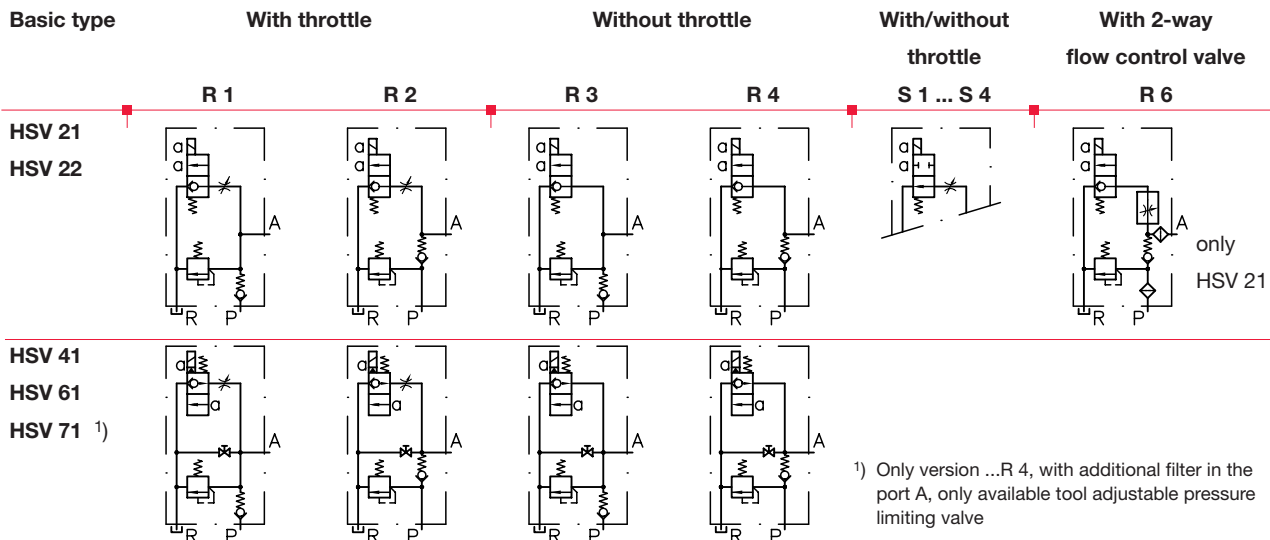

Solenoid voltage

- 12V DC, 24V DC, 230V AC 50/60 Hz
- Other voltage on request
- Versions conforming ATEX only type HSV 21 and HSV 22

- Plug with LED, improving EMC, or with economy circuit (see also section "Additional information")

Additional versions

Twin version of the lifting/lowering valve for two single acting consumers (type HZV 2 ..)

Order examples**HSV 21 - R4R - 150 - G24**

Lifting/lowering valve type HSV, size 21, flow pattern R 4 without throttle, (manually adjustable pressure limiting valve, coding R) set to 150 bar, solenoid voltage 24V DC

HSV 41 - R2 - 220 - WG230

Lifting/lowering valve type HSV, size 41, with flow pattern R 2, tool adjustable pressure limiting valve (set to 220 bar), solenoid voltage 230V AC 50/60 Hz

Dimensions**Type HSV 21-.. and HSV 22-..**

(see order example)

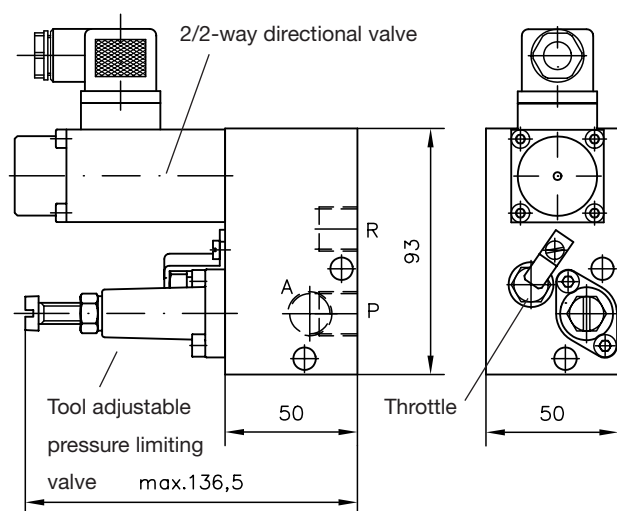
**Type HSV 41-.., HSV 61-.. and HSV 71-..**

(see order example)

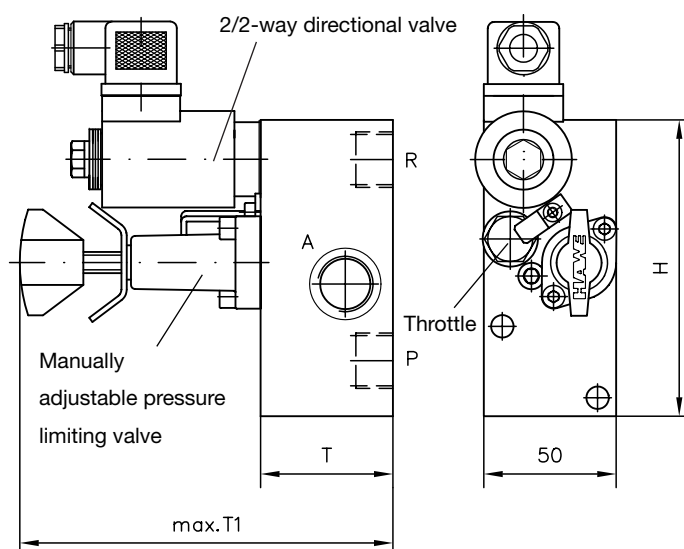

Type	H	T	T1 max.	m (kg)
HSV 41	112	50	140	2.2
HSV 61	100	63	166.5	2.5
HSV 71	100	80	160	3.1

Additional information

- Lifting/lowering valves type HSV, HZV D 7032
- Plug with LED etc. D 7163
- Plug with economy circuit D 7813, D 7833
- Connection blocks type B D 6905 B

- See also "Turn-key solution out of the modular system" (Devices for explosion hazardous areas, conforming ATEX)

For page and section of the devices additionally listed, see type index