

Check valves with hydraulic release type HRP

The check valves type HR with hydraulic release, are designed as manifold mounting valves and are available in six sizes. These valves are used in hydraulic circuits with design related, leaking directional valves, as hydraulically actuated drain, or idle circulation valves. The check valve type HRP can be ordered also with a pre-release to suppress decompression surges for circuits with high pressure and high consumer flows. This valve is tolerant to residual pressure in the return duct (port B) as the rear side of the actuation piston is depressurized via a leakage port. Another option allows opening of the check valve via the load pressure on the consumer side, controlled by a directly mounted solenoid valve.

Nomenclature: Check valve with hydraulic release

Design: Manifold mounting valve

Actuation: Hydraulic

p_{max} : 700 ... 500 bar

Q_{max} : 20 ... 400 lpm

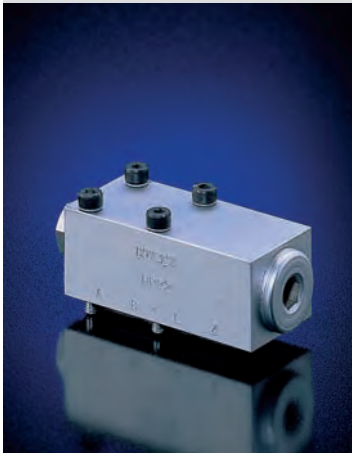

Basic types and general parameters

Basic type and size	Flow Q_{max} (lpm)	Pressure p_{max} (bar)	Release ratio p_A / p_Z
HRP 1	20	700	2.9
HRP 2	35	700	3.9
HRP 3	50	500	4.3
HRP 4	80	500	3.8
HRP 5	140	500	4.0
HRP 7 V	400	500	3.0

Symbol

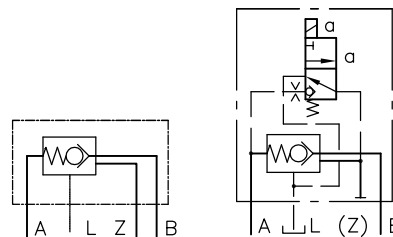

2
5

Additional versions

- Check valve with pre-release type HRP..V

- Orifice inserts installed in port Z to prevent decompression surges

Order example

HRP 3

Check valve with hydraulic release type HRP, size 3

HRP 5 - WH1 - H B 0,4 - G24

Check valve type HRP with hydraulic release, size 5 and directly mounted 3/2-way solenoid valve enabling arbitrary release or to be used as 2/2-way valve

Dimensions

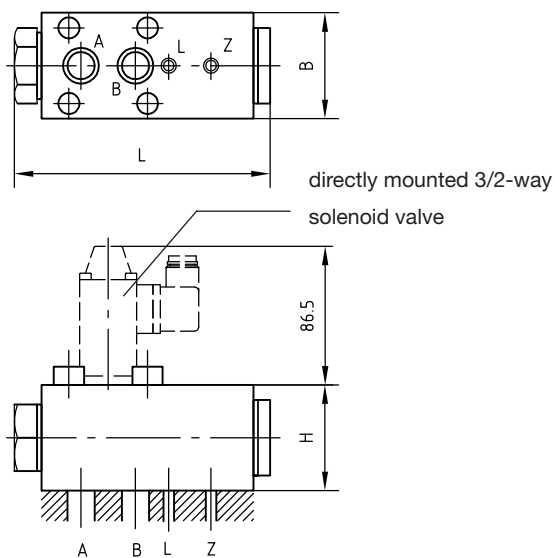

Basic type	L	B	H	m (kg)
HRP 1	74.5	25	20	0.25
HRP 2	78	30	25	0.4
HRP 3	83	35	35	0.7
HRP 4	103.5	50	35	1.2
HRP 5	110.5	60	40	1.9
HRP 7 V	190	100	63	8.0

All dimensions in mm, subject to change without notice!

Further information

- Check valves type HRP
 - type RH D 5116
 - type RHV D 6105
 - type RHC D 3056
 - type CRH D 7165
 - type CRH D 7712
- Releasable twin check valve type DRH D 6110

- See also section “Devices for special applications”
(Devices for up to 700 bar)

For page and section of the devices additionally listed, see type index